

Drainage systems.

**Channels, gratings
and accessories**



CONTENTS

DRAINAGE SYSTEMS

ADVANCED SYSTEMS FOR RELIABLE DRAINAGE	14
FOR ALL LOADS, IN ANY URBAN CONTEXT	16
THE OPTIMAL SOLUTION FOR ANY DRAINAGE NEEDS	18
VIBRO-COMPRESSED CONCRETE CHANNELS	20
VIBRO-BASE SERIES	22
VIBRO-BASE SERIES - SYSTEM AND TECHNICAL CHARACTERISTICS	24
VIBRO-BASE 100 SERIES	26
VIBRO-BASE 100 EVO SERIES	28
VIBRO-BASE 100 SERIES WITH THIN COVER - CENTRAL SLOT	30
VIBRO-BASE 100 SERIES WITH THIN COVER - SIDE SLOT	32
VIBRO-BASE 150 SERIES	34
VIBRO-BASE 150 EVO SERIES	36
VIBRO-BASE 150 SERIES WITH THIN COVER - CENTRAL SLOT	38
VIBRO-BASE 150 SERIES WITH THIN COVER - SIDE SLOT	40
VIBRO-BASE 200 SERIES	42
VIBRO-BASE 200 EVO SERIES	44
VIBRO-BASE 200 SERIES WITH THIN COVER - CENTRAL SLOT	46
VIBRO-BASE 200 SERIES WITH THIN COVER - SIDE SLOT	48
R SERIES	50
R SERIES - SYSTEM AND TECHNICAL CHARACTERISTICS	52
R SERIES - RAISING FRAME FOR TWO-STAGE LAYING	54
R 122 SERIES	55
R 150 SERIES	56
R 210 SERIES	58
R 265 SERIES	60
R 315 SERIES	62
R 365 SERIES	64
R 495 SERIES	66
R 595 SERIES	67
R 150 SERIES WITH DUCTILE IRON EDGE RAIL	68
R 210 SERIES WITH DUCTILE IRON EDGE RAIL	70
R 265 SERIES WITH DUCTILE IRON EDGE RAIL	72
R 315 SERIES WITH DUCTILE IRON EDGE RAIL	74
R 365 SERIES WITH DUCTILE IRON EDGE RAIL	76
REINFORCED CONCRETE CHANNELS	78
K SERIES	80
K SERIES - TECHNICAL CHARACTERISTICS	82
K 170 SERIES	83
K 220 SERIES	84
K 270 SERIES	85

K 270 LOWERED SERIES	86
K 350 SERIES	87
K 400 SERIES	88
C SERIES	90
C SERIES - TECHNICAL CHARACTERISTICS	92
C500	93
C600	94
C700	95
C800	96
XL SERIES	98
XL SERIES - TECHNICAL CHARACTERISTICS	100
XL 410 SERIES	101
POLYMER CONCRETE CHANNELS	102
BASE SERIES	104
BASE SERIES - SYSTEM AND TECHNICAL CHARACTERISTICS	106
BASE 100 SERIES	108
BASE 100 EVO SERIES	110
BASE 100 SERIES WITH THIN COVER - CENTRAL SLOT	112
BASE 100 SERIES WITH THIN COVER - SIDE SLOT	114
BASE 100 LOW SERIES	116
BASE 100 LOW EVO SERIES	118
BASE 100 LOW SERIES WITH THIN COVER - CENTRAL SLOT	120
BASE 100 LOW SERIES WITH THIN COVER - SIDE SLOT	122
BASE 150 SERIES	124
BASE 150 EVO SERIES	126
BASE 150 SERIES WITH THIN COVER - CENTRAL SLOT	128
BASE 150 SERIES WITH THIN COVER - SIDE SLOT	130
BASE 200 SERIES	132
BASE 200 EVO SERIES	134
BASE 200 SERIES WITH THIN COVER - CENTRAL SLOT	136
BASE 200 SERIES WITH THIN COVER - SIDE SLOT	138
P SERIES	140
P SERIES - SYSTEM AND TECHNICAL CHARACTERISTICS	142
P 150 SERIES	144
P 150 LOWERED SERIES	146
P 210 SERIES	148
P 210 LOWERED SERIES	150
P 265 SERIES	152
P 315 SERIES	154
P 365 SERIES	156

P 150 SERIES WITH DUCTILE IRON EDGE RAIL	158
P 210 SERIES WITH DUCTILE IRON EDGE RAIL	160
P 265 SERIES WITH DUCTILE IRON EDGE RAIL	162
P 315 SERIES WITH DUCTILE IRON EDGE RAIL	164
P 365 SERIES WITH DUCTILE IRON EDGE RAIL	166
POLY FLY SERIES	168
POLY FLY SERIES - SYSTEM AND TECHNICAL CHARACTERISTICS	170
POLY FLY SERIES - SPECIAL COVERS	172
POLY FLY 100 - GALVANISED EDGE RAIL	174
POLY FLY 100 - AISI 304 STAINLESS STEEL EDGE RAIL	176
POLY FLY 100 WITH SPECIAL COVER	178
POLY FLY 100 WITH THIN COVER - CENTRAL SLOT	180
POLY FLY 100 WITH THIN COVER - SIDE SLOT	182
POLY FLY 100 LOW - GALVANISED EDGE RAIL	184
POLY FLY 100 LOW - AISI 304 STAINLESS STEEL EDGE RAIL	186
POLY FLY 100 LOW WITH SPECIAL COVER	188
POLY FLY 100 LOW WITH THIN COVER - CENTRAL SLOT	190
POLY FLY 100 LOW WITH THIN COVER - SIDE SLOT	192
POLY FLY 100 WITH SLOPE - GALVANISED EDGE RAIL	194
POLY FLY 100 WITH SLOPE - AISI 304 STAINLESS STEEL EDGE RAIL	196
POLY FLY 100 WITH SLOPE WITH SPECIAL COVER	198
POLY FLY 100 WITH SLOPE WITH THIN COVER - CENTRAL SLOT	200
POLY FLY 100 WITH SLOPE WITH THIN COVER - SIDE SLOT	202
POLY FLY 100 WITH SLOPE WITH THIN COVER AISI 304 STAINLESS STEEL EDGE RAIL - CENTRAL SLOT	204
POLY FLY 100 WITH SLOPE WITH THIN COVER AISI 304 STAINLESS STEEL EDGE RAIL - SIDE SLOT	206
POLY FLY 150 - GALVANISED EDGE RAIL	208
POLY FLY 150 - AISI 304 STAINLESS STEEL EDGE RAIL	210
POLY FLY 150 LOW - GALVANISED EDGE RAIL	212
POLY FLY 150 LOW - AISI 304 STAINLESS STEEL EDGE RAIL	214
POLY FLY 150 WITH SLOPE - GALVANISED EDGE RAIL	216
POLY FLY 150 WITH SLOPE - AISI 304 STAINLESS STEEL EDGE RAIL	218
POLY FLY 200 - GALVANISED EDGE RAIL	220
POLY FLY 200 - AISI 304 STAINLESS STEEL EDGE RAIL	222
POLY FLY 200 LOW - GALVANISED EDGE RAIL	224
POLY FLY 200 LOW - AISI 304 STAINLESS STEEL EDGE RAIL	226
POLY FLY 300 HIGH - GALVANISED EDGE RAIL	228
POLY FLY 300 HIGH - AISI 304 STAINLESS STEEL EDGE RAIL	230
POLY FLY 300 MEDIUM - GALVANISED EDGE RAIL	232

POLY FLY 300 MEDIUM - AISI 304 STAINLESS STEEL EDGE RAIL	234
POLY FLY 300 LOW - GALVANISED EDGE RAIL	236
POLY FLY 300 LOW - AISI 304 STAINLESS STEEL EDGE RAIL	238
ABS CHANNELS	240
PLASTIC FLY SERIES	242
PLASTIC FLY SERIES - SYSTEM AND TECHNICAL CHARACTERISTICS	244
PLASTIC FLY 100	246
PLASTIC FLY 100 WITH THIN COVER - CENTRAL SLOT	248
PLASTIC FLY 100 WITH THIN COVER - SIDE SLOT	250
PLASTIC FLY 100 LOW	252
PLASTIC FLY 100 LOW WITH THIN COVER - CENTRAL SLOT	254
PLASTIC FLY 100 LOW WITH THIN COVER - SIDE SLOT	256
PLASTIC FLY 150	258
PLASTIC FLY 150 LOW	260
PLASTIC FLY 200	262
PLASTIC FLY 200 LOW	264
ALTERNATIVE DRAINAGE SYSTEMS	266
WATERTRAP SUMP UNITS FOR BRIDGES	268
WATERTRAP SUMP UNITS FOR BRIDGES - SYSTEM AND TECHNICAL CHARACTERISTICS	270
WATERTRAP	271
DRAINAGE SYSTEMS FOR ROOF GARDENS SOFT DRAIN CHANNELS	272
DRAINAGE SYSTEMS FOR ROOF GARDENS - SYSTEM AND TECHNICAL CHARACTERISTICS	274
SOFT DRAIN 100 CHANNELS	276
SOFT DRAIN 150 CHANNELS	277
SOFT DRAIN 200 CHANNELS	278
ECOLOGICALLY SUSTAINABLE DRAINAGE SYSTEMS	280
ENVIRO SERIES	282
ENVIRO SERIES - SYSTEM AND TECHNICAL CHARACTERISTICS	284
ENVIRO CHANNELS	286
ENVIRO DECKS	288
ENVIRO KERBS	294
IT - KERBS	301
TECHNICAL DATA	302
HYDRAULIC CALCULATIONS	304
FLOW RATE TABLES	304
LOAD CLASSES	306
INSTALLATION, USE AND MAINTENANCE SHEETS	308
GLOSSARY	309



Gridiron. 40 years of Italian history

Gridiron was founded in **1979 in Italy**, in Mareno di Piave, thanks to the entrepreneurship and tenacity of **Giancarlo Zanette**, and is currently present in over **36 countries worldwide** as a cutting-edge company operating in the public and private building sectors.

The Gridiron range includes **technical gratings, drainage systems, doormats** and **building accessories** that are fitted in monumental buildings in central **London**, drain water from the **San Giorgio Bridge**, serve as components in oil rigs in the **Atlantic Ocean** and equip luxury **public** and **private** facilities, where they combine functionality and aesthetics.

Gridiron, which is still firmly headed by the **Zanette family**, currently organises its production, research and development activities in various plants covering a total surface area of **70,000 m²** located in North-Eastern Italy, where it relies on the precious contribution of **150 people**.

Gridiron.

A single answer for multiple solutions

Knowing **steel** and processing **it to make technical gratings** has led us to develop new product categories over the years: **technical doormats**, **building accessories** and **drainage channels**.

For the latter, we started out as suppliers of covers and soon decided to manufacture the entire system in-house, driven – as always – by our desire to bring **a unique know-how** to the market.

Our **standard products** provide endless **customisation** options, offering the ideal solution for every application, from **major works** to **exclusive projects**.

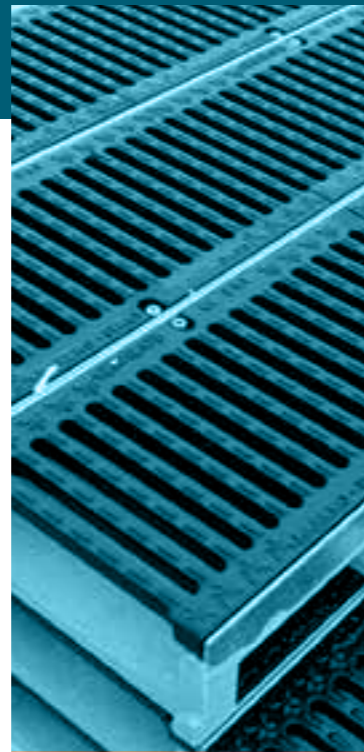

Drainage systems

We are the **only** company in **Europe** to manufacture the **entire drainage system** (channels, profiles, gratings, sump units and accessories) in **three different materials** (polymer concrete, vibro-compressed and reinforced concrete, ABS).

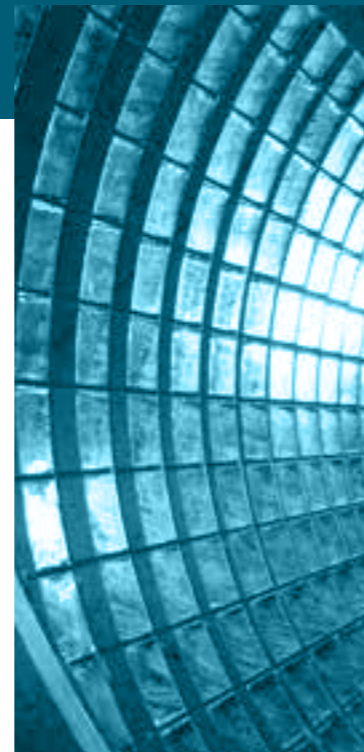

Metal gratings

Our origins are inextricably linked to **gratings**, an extremely **versatile** product which we manufacture in the **forge-welded** and **pressure-locked** versions, in galvanised steel, **stainless steel** and **aluminium**. Moreover, we are among Europe's leading manufacturers of **sun screens** and **wind screens**, and offer a broad range of **steps**, **fences** and **gates** for industrial and domestic use.



Stainless steel drainage systems

Stainless steel: the perfect material for satisfying **aesthetic requirements**, indispensable in all sectors that require **resistance to corrosion** and compliance with **hygiene and health regulations** (petrochemical, mining, pharmaceutical, food processing industries, etc.). The Gridiron range includes an extensive range of **basins**, **channels**, **standard**, or **custom wastes**.



Building accessories

Our range of building **accessories** has expanded over the years to include **manhole covers** and **standard** and **custom plates**, **window wells** and **standard gratings**. The range includes cutting-edge systems such as the **"Key"** manhole cover (**watertight**), the **"Green"** model (**draining** version for gardens), and many more.

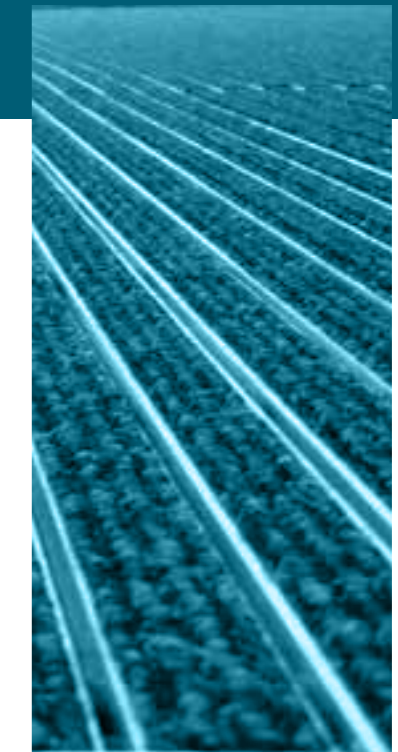

Technical doormats

Gridiron doormats combine **visual appeal**, **functionality** and **safety**, and are all equipped with a **soundproofing** base. Available in various thicknesses, colours and types of coatings, they are entirely **customisable**. Be it the hall of a luxury hotel or the entrance to an **airport**, a **company** or a **building**, Gridiron will be able to guide you right from the design phase to the final installation.

Gridiron. Certificates



ISO 9001: industrial excellence

The certification in accordance with the **ISO 9001** standard guarantees the maintenance and ongoing improvement of the **quality** of its **goods** and **services**, through **monitoring** of all **processes** and the measurement of **results**.

In an increasingly complex and cluttered global market, this becomes an important factor that drives **customers** to **choose** the company, acknowledging its **high-quality standard** and **reliability** at an international level.



Product certifications

Our products are **CE**-marked in accordance with relevant standards:

Drainage channels: EN 1433

Gates: EN 13241

Welded steel components: EN 1090

The latter, in particular, offers further proof of our commitment towards the **safety** of our **operators**.





Gridiron. Raw materials and technologies

Our **unique** and **innovative approach** on the market derives from our success in merging two aspects that have elevated **"Made in Italy"** to world fame: the art of **working** matter and advanced **technological research**. This has allowed us to become **experts** in new creations, and it is also the secret behind our ability to operate with a **flexible** and highly **customised** approach.

Since the outset we have been collaborating with **premium suppliers**, with which we have established a relationship based on **trust** and mutual **esteem**: a further guarantee of our reliability and professional approach, allowing us to manufacture **qualitatively excellent** products for our customers.

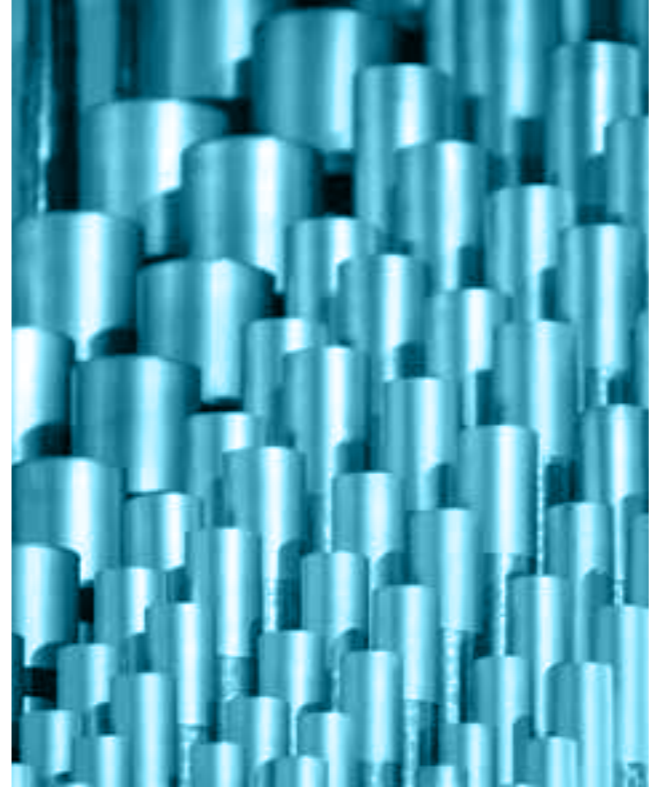

We work with **pickled** and **galvanised** strips that are **heavier** than the market average, resulting in **better performance** for our machinery and product **finishes** that are better and significantly **longer-lasting**. Thanks to a **production process** that is carried out **entirely in-house**, our products can fulfil requirements for **any shape** and **size**.

We choose to **test** each product internally, in our **Research and Development department**, where we conduct tests that are **even more rigorous** than those prescribed by the sector standards. **We invest** constantly in the implementation of **new processes**, the introduction of **innovative software** and the purchase of **new-generation machines**, which are then **re-engineered internally**, making the **quality** of Gridiron products unique and non-reproducible.



Gridiron. Services

From **design** to **installation** consulting and **logistics**, Gridiron is a solid **partner** for our customers, for a reliable **collaboration** covering all aspects.

Ever since the beginning we realised the importance of being able to offer a **product** in the **broader sense**, where “product” refers not only to the material outcome but also to the ecosystem that is intimately bound to it, where **services, relations** and **experiences** all merge.

We operate with care at every step of the process, from the initial contact with the customer to the delivery of our products. Also when we prepare the **shipment**, we study the loads so that the unloading and assembly operations can be carried out smoothly and effectively.

Our main services:

- Preventive analysis**
- Solution research**
- Design**
- Load calculations**
- Drafting of specifications**
- Installation instructions**
- Fast and smart logistics service**



ADVANCED SYSTEMS FOR RELIABLE DRAINAGE

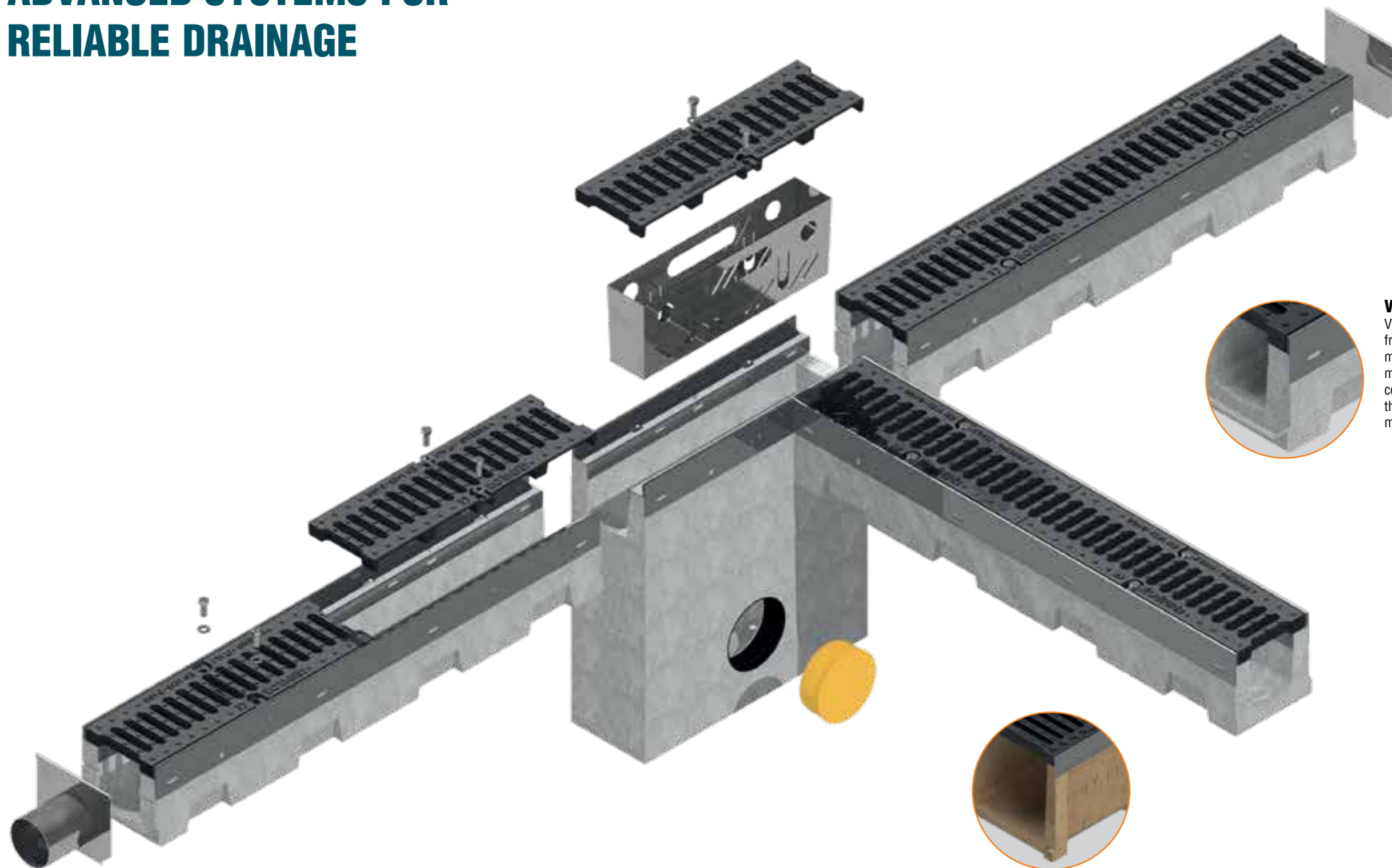

ABS

ABS is an acronym identifying a family of thermoplastic materials. The acronym derives from the three monomers used in producing ABS, namely acrylonitrile, butadiene and styrene.

PHYSICAL AND CHEMICAL PROPERTIES:

Shape: channel
Colour: black
Odour: slight specific odour
Softening point: above 70°C
Ignition temperature: above 400°C
Fire-inducing elements: none
Density: roughly 1.06 kg/dm³ (water = 1)
Solubility in water: insoluble
Solubility in other solvents: soluble in aromatic solvents



VIBRO-COMPRESSED CONCRETE

Vibro-compressed concrete is obtained from a mixture of certified riverbed inert materials and Grade 425 concrete, that make the channels highly resistant to compression (**R_{ck}>45N/mm²**), frost and thaw cycles, climate-induced erosion and mechanical stress.

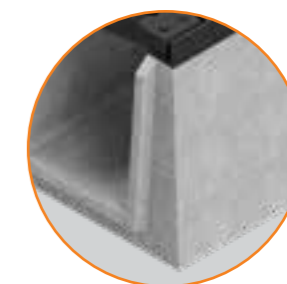

REINFORCED CONCRETE

Concrete reinforced with a metal reinforcement guarantees a compressive strength of **600 kg/cm²**, a tensile strength of **50 kg/cm²** and a water absorption between **1% and 3%**.



POLYMER CONCRETE

Cast polymer concrete is obtained through a mixture of inert quartz materials and polymer resins with the addition of catalysts. Their mechanical resistance and compressive strength hover around 1,000–1,200 kg/cm², while their tensile strength is roughly 200–250 kg/cm².

PHYSICAL AND CHEMICAL PROPERTIES:

Shape: channel
Colour: brown
Odour: slight specific odour
Water absorption: less than 0.1%, waterproof and thus frost-resistant
Absorption of food substances: less than 0.1%. Recommended in rooms where there is contact with foodstuffs.
Fire rating: Class 1
Solubility in water: insoluble
Solubility in other solvents: insoluble

FOR ALL LOADS, IN ANY URBAN CONTEXT

Drainage systems conforming to the UNI EN 1433:2008 standard, from A15 to F900

The choice of the type, size and load class of the drainage system depend on the specific project.

The Gridiron Technical Department is nonetheless available to offer consulting and solutions stemming from field experience.

PEDESTRIAN AREAS

URBAN AREAS

ROADS / HIGHWAYS

INDUSTRIAL AREAS

LARGE INFRASTRUCTURES



A 15

Areas that can be used exclusively by pedestrians and cyclists.

kN 15

B 125

Pedestrian pathways, pedestrian areas and similar areas, private car parks or multi-storey car parks.

kN 125

C 250

Kerbsides and areas of docks and similar not exposed to traffic; the kerb elements always fall at least within Class C250.

kN 250

D 400

Carriageways (including pedestrian roads), verges and parking areas for all types of road vehicles.

kN 400

E 600

Areas subject to large wheel loads, e.g. in harbours and dockyards.

kN 600

F 900

Areas subject to very high wheel loads, e.g. aircraft paving.

kN 900

THE OPTIMAL SOLUTION FOR ANY DRAINAGE NEEDS

A complete range of channels, gratings, accessories and... useful tips

Below is a broad grouping of Gridiron drainage systems according to the type of material, load class and application context.



VIBRO-COMPRESSED CONCRETE CHANNELS

Innovative and highly products at a competitive price

LOAD CLASS
A 15 • B 125 • C 250
D 400 • E 600 • F 900



REINFORCED CONCRETE CHANNELS

Exceptional resistance

LOAD CLASS
F 900



POLYMER CONCRETE CHANNELS

Conveniently priced products offering a high level of quality and safety

LOAD CLASS
A 15 • B 125 • C 250
D 400 • E 600 • F 900



ABS CHANNELS

Excellent mechanical resistance, lightweight, and easy to transport and install

LOAD CLASS
A 15 • B 125 • C 250
D 400



ALTERNATIVE DRAINAGE SYSTEMS

Recovery of waste water from bridges without the aquaplaning effect

LOAD CLASS
• D 400 Watertrap
• A15 Soft Drain



SUSTAINABLE DRAINAGE

100% recycled materials, lightweight, eco-friendly and easy to install

LOAD CLASS
• D 400



GRIDIRON®

CHANNELS MADE OF
**VIBRO-COMPRESSED
CONCRETE**

PAGE
22

VIBRO-BASE SERIES

PAGE
50

R SERIES



GRIDIRON®
BUILD YOUR CHANGES

VIBRO-COMPRESSED CONCRETE CHANNELS

VIBRO-BASE SERIES

The new generation of GRIDIRON VIBRO-BASE SERIES vibro-compressed channels is the result of a careful, precise design. It introduces innovation and perfection to the water channelling sector at a reduced cost, being in the low-end of the range.

Vibro-compressed concrete is obtained from a mixture of certified riverbed inert materials and Grade 425 concrete, combined with vibration and compression processing methods that make VIBRO-BASE SERIES channels highly resistant to compression ($R_{cK} > 45N/mm^2$), frost and thaw cycles, climate-induced erosion and mechanical stress.

The GJS500-7 ductile iron gratings, housed directly on the channel edges, are fastened with stainless steel screws to uniformly distribute the stress generated by the passage of vehicles, while guaranteeing stability and silence.

The classification and control procedures comply with the European UNI EN 1433 standard.

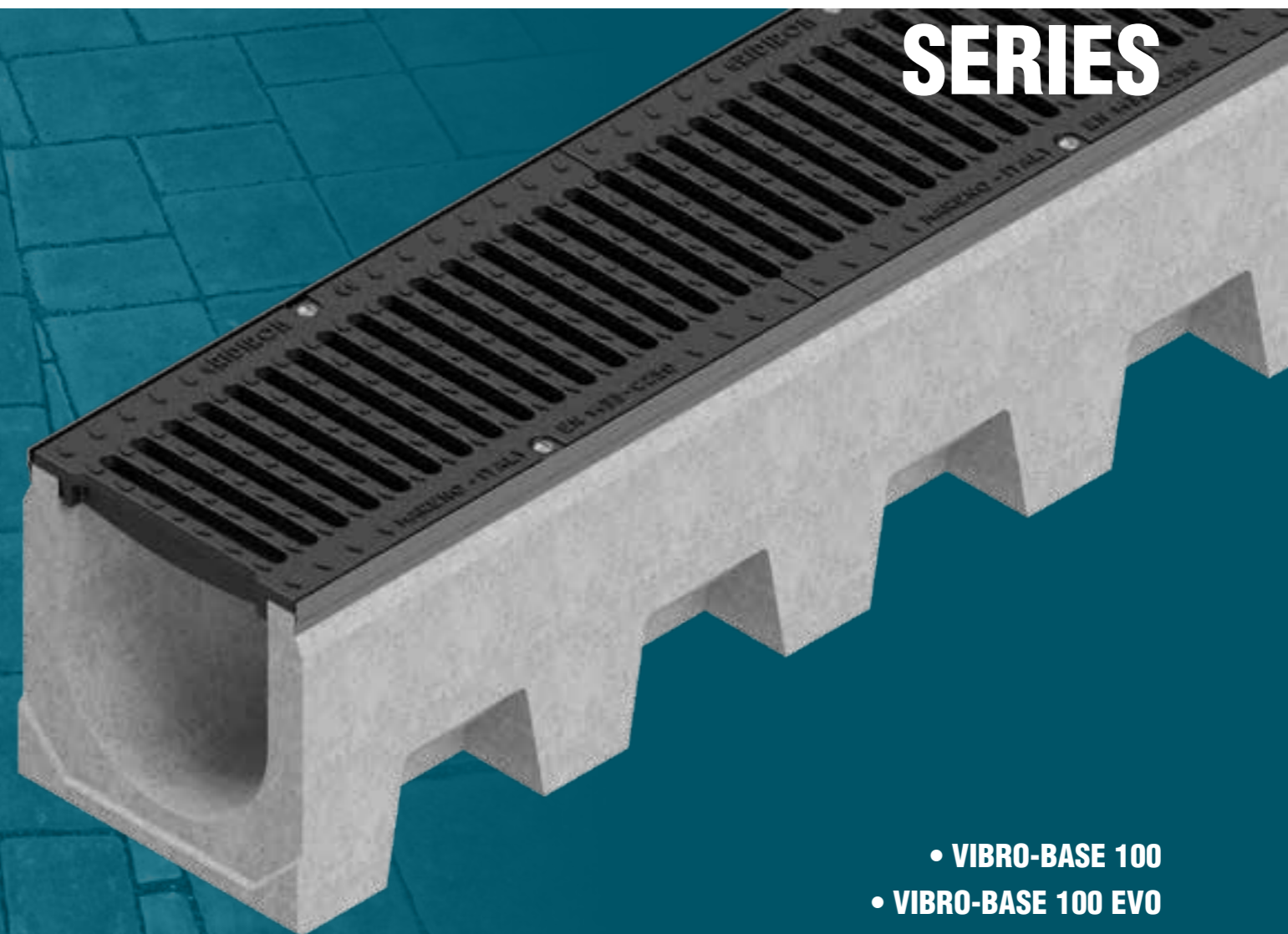

- VIBRO-BASE 100
- VIBRO-BASE 100 EVO
- VIBRO-BASE 150
- VIBRO-BASE 150 EVO
- VIBRO-BASE 200
- VIBRO-BASE 200 EVO



LOAD CLASSES

In accordance with the UNI EN 1433 standard



A 15 • B 125 • C 250



VIBRO-COMPRESSED CONCRETE CHANNELS VIBRO-BASE SERIES

SYSTEM AND TECHNICAL CHARACTERISTICS



DUCTILE IRON GRATINGS SECURED TO THE CHANNEL
The gratings have two relief notches along their lower section which slot into the relative housings on the edge of the channel to prevent their longitudinal movement.

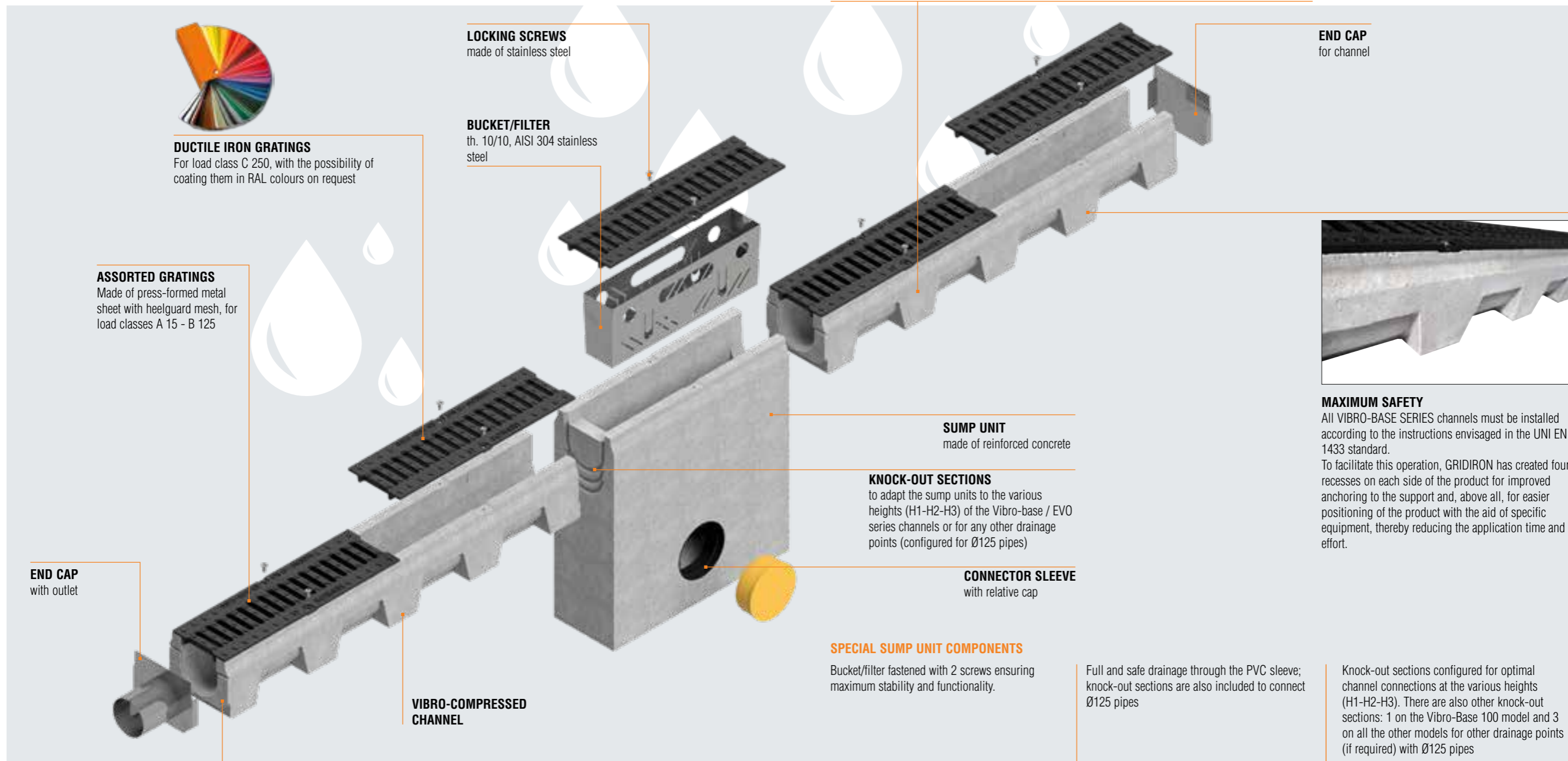

MAXIMUM SAFETY
All VIBRO-BASE SERIES channels must be installed according to the instructions envisaged in the UNI EN 1433 standard. To facilitate this operation, GRIDIRON has created four recesses on each side of the product for improved anchoring to the support and, above all, for easier positioning of the product with the aid of specific equipment, thereby reducing the application time and effort.



PERFECT AND STABLE JOINING
The channel end caps are made with male-female connections, with an inner slot that allows for sealing them together. It is advisable to use silicone sealant with neutral cross-linkage and low modulus.

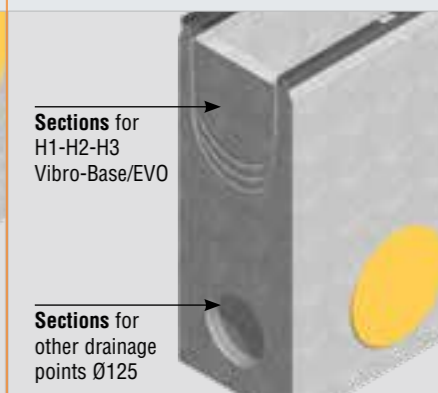
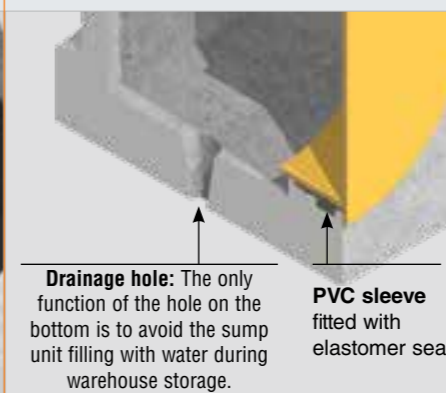
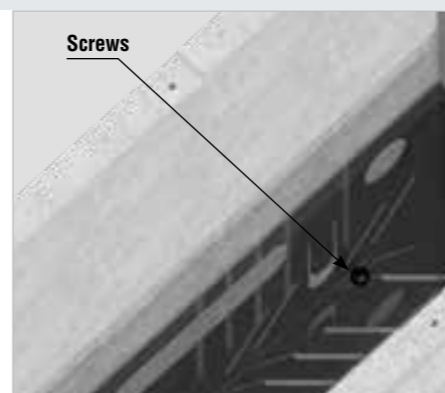

Drainage hole: The only function of the hole on the bottom is to avoid the sump unit filling with water during warehouse storage.

PVC sleeve fitted with elastomer seal

Sections for H1-H2-H3 Vibro-Base/EVO

Sections for other drainage points Ø125

VIBRO-COMPRESSED CONCRETE CHANNELS

VIBRO-BASE 100 SERIES

Grating width 150 mm

Vibro-compressed concrete channel.
The channels are sold exclusively in complete pallets and together with the gratings.



Vibro-Base 100 Series channel dimensions

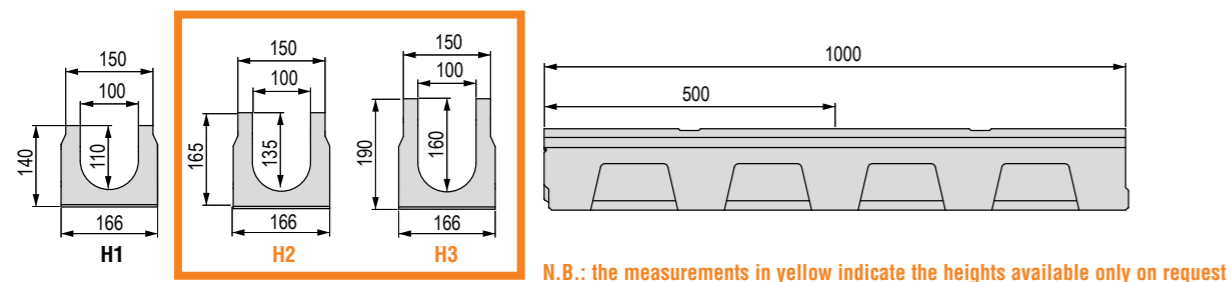

Available gratings

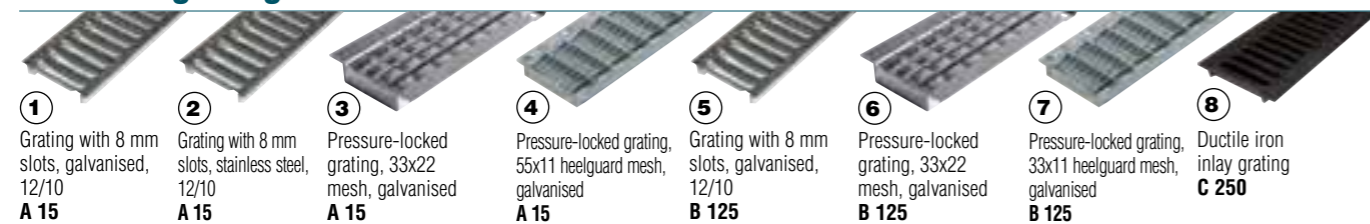

Vibro-Base 100 Series channel complete with grating - Length 1,000 / 500 mm

Channel L mm	Code	Grating	Description of the H1 channel assembled with the grating complete with accessories	Weight kg	Load class
1,000	4F00SGL	①	Channel complete with self-locking inlay grating made of galvanised press-formed metal sheet, 8 mm slots, 12/10	30.11	A 15
	4F00SGLI	②	Channel complete with self-locking inlay grating made of AISI 304 stainless steel press-formed metal sheet, 8 mm slots, 12/10	30.93	
	4F00SA	③	Channel complete with pressure-locked inlay grating 20x2-10x2 33x22, hot-dip galvanised	30.49	
	4F00SAA	④	Channel complete with pressure-locked heelguard inlay grating 20x2-10x2 55x11, hot-dip galvanised	31.04	
	4F00SGL1	⑤	Channel complete with self-locking inlay grating made of galvanised press-formed metal sheet, 8 mm slots, 12/10 (suitable for sports facilities)	30.15	
	4F00SB	⑥	Channel complete with pressure-locked inlay grating 30x2-10x2 33x22, hot-dip galvanised	31.75	B 125
	4F00SBA	⑦	Channel complete with pressure-locked heelguard inlay grating 30x2-10x2 33x11, hot-dip galvanised	31.54	
	4F00SGS	⑧	Channel complete with 2 x GJS500-7 ductile iron inlay gratings	35.36	
500	4F05SGL	①	Channel complete with inlay grating made of galvanised press-formed metal sheet, 8 mm slots, 12/10	15.10	A 15
	4F05SGLI	②	Channel complete with inlay grating made of AISI 304 stainless steel press-formed metal sheet, 8 mm slots, 12/10	15.46	
	4F05SA	③	Channel complete with pressure-locked inlay grating 20x2-10x2 33x22, hot-dip galvanised	15.25	
	4F05SAA	④	Channel complete with pressure-locked heelguard inlay grating 20x2-10x2 55x11, hot-dip galvanised	15.52	
	4F05SGL1	⑤	Channel complete with self-locking inlay grating made of galvanised press-formed metal sheet, 8 mm slots, 12/10 (suitable for sports facilities)	15.07	B 125
	4F05SB	⑥	Channel complete with pressure-locked inlay grating 30x2-10x2 33x22, hot-dip galvanised	15.88	
	4F05SBA	⑦	Channel complete with pressure-locked heelguard inlay grating 30x2-10x2 33x11, hot-dip galvanised	15.77	
	4F05SGS	⑧	Channel complete with GJS500-7 ductile iron inlay grating	17.68	

Vibro-Base 100 Series accessories

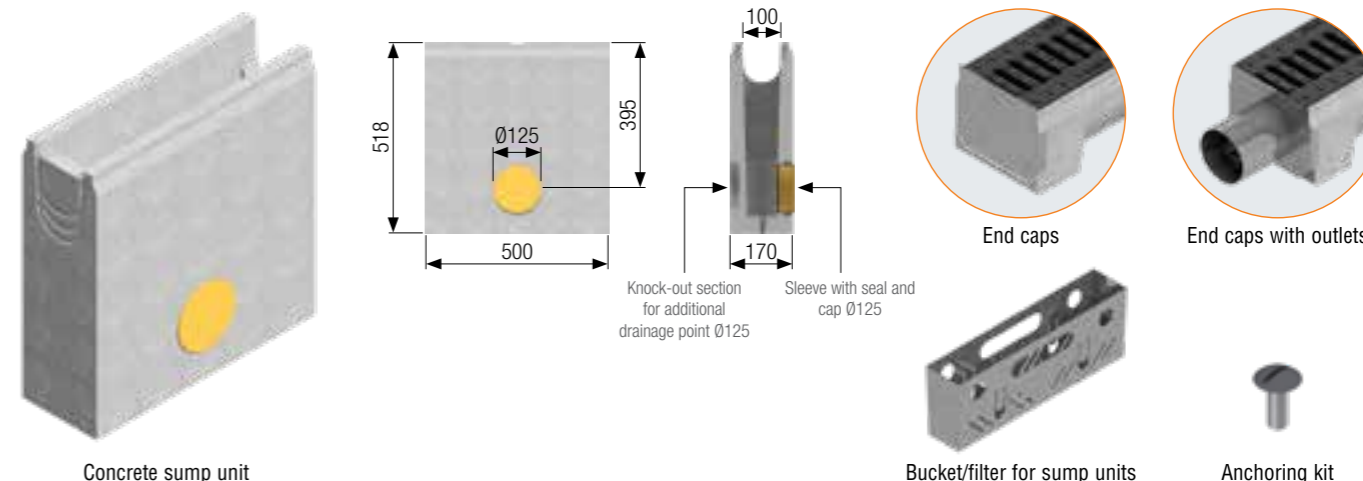

Vibro-Base 100 Series concrete sump unit complete with grating - Length 500 mm

Sump unit L mm	Code	Grating	Description of the sump unit assembled with the grating complete with accessories	Weight kg	Load class
500	4F00PZGL	①	Sump unit complete with self-locking inlay grating in press-formed metal sheet, galvanised, 8 mm slots, 12/10	61.40	A 15
	4F00PZGLI	②	Sump unit complete with self-locking inlay grating made of AISI 304 stainless steel press-formed metal sheet, 8 mm slots, 12/10	61.40	
	4F00PZA	③	Sump unit complete with pressure-locked inlay grating 20x2-10x2 33x22, hot-dip galvanised	61.90	
	4F00PZAA	④	Sump unit complete with pressure-locked heelguard inlay grating 20x2-10x2 55x11, hot-dip galvanised	61.90	
	4F00PZGL1	⑤	Sump unit complete with inlay grating made of galvanised press-formed metal sheet, 8 mm slots, 12/10 (suitable for sports facilities)	61.40	
	4F00PZB	⑥	Sump unit complete with pressure-locked inlay grating 30x2-10x2 33x22, hot-dip galvanised	62.05	B 125
	4F00PZBA	⑦	Sump unit complete with pressure-locked heelguard inlay grating 30x2-10x2 33x11, hot-dip galvanised	62.10	
	4F00PZGS	⑧	Sump unit complete with GJS500-7 ductile iron inlay grating	63.60	

Vibro-Base 100 Series concrete sump unit without grating and accessories

Code	Description	Weight kg
4F00PZ	Reinforced concrete sump unit L 500 mm	60.20
4R01VI	Bucket/Filter, AISI 304 stainless steel	1.16
4F00TI	End cap h140	0.28
4F01TI	End cap h165	0.33
4F02TI	End cap h190	0.38
4F00RI	End cap with outlet drainage pipe diam. 89 mm for channel h140	0.58
4F01RI	End cap with outlet drainage pipe diam. 89 mm for channel h165	0.63
4F02RI	End cap with outlet drainage pipe diam. 89 mm for channel h190	0.68
4510K	Kit for anchoring the grating to the channel and sump unit Channel bottom drilling Ø82 mm	0.024

Vibro-Base 100 Series channel without grating - Length 1,000 / 500 mm

Channel L mm	Code	Description	Water passage mm	Run-off section cm ²	Weight kg	Pieces pallet
1,000	4F00S	Vibro-compressed concrete channel H1	100	99	27.74	42
	4F01S	Vibro-compressed concrete channel H2	100	124	31.17	42
	4F02S	Vibro-compressed concrete channel H3	100	149	33.60	42
500	4F05S	Vibro-compressed concrete channel H1	100	99	13.87	loose
	4F06S	Vibro-compressed concrete channel H2	100	124	15.92	loose
	4F07S	Vibro-compressed concrete channel H3	100	149	16.80	loose

VIBRO-COMPRESSED CONCRETE CHANNELS

VIBRO-BASE 100 EVO SERIES

(with edge rail)

Grating width 150 mm

Vibro-compressed concrete channel with galvanised protective edge rails. The channels are sold exclusively in complete pallets and together with the gratings.

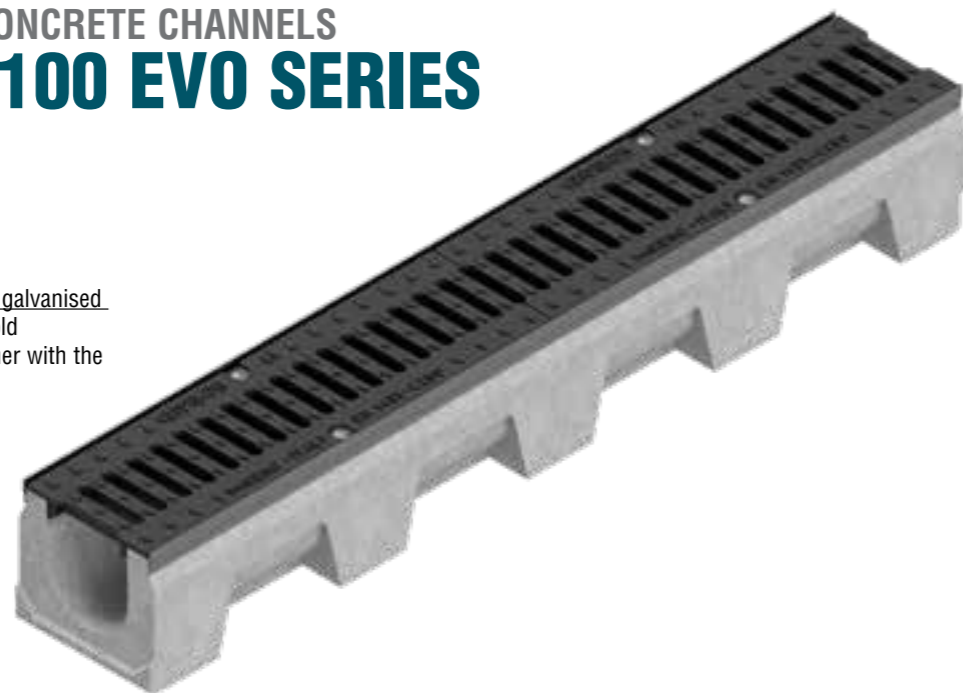

Vibro-Base 100 EVO channel dimensions

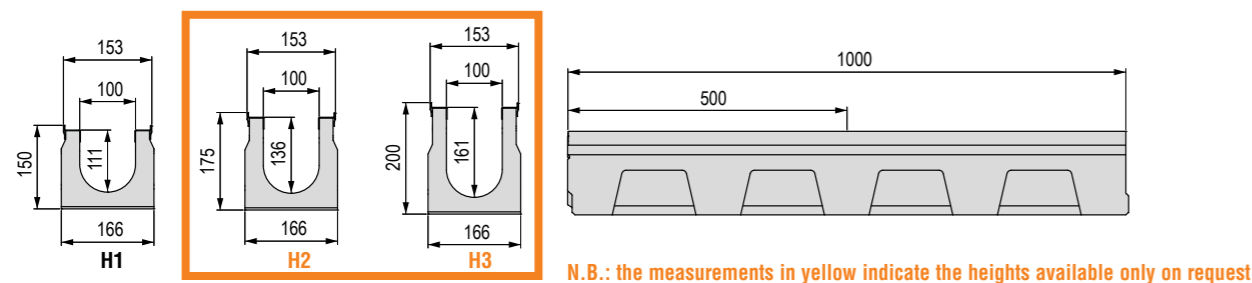

Available grating

GJS500-7 ductile iron inlay grating
C 250



Vibro-Base 100 EVO Series channel complete with grating - Length 1,000 / 500 mm

Channel L mm	Code	Description of the H1 channel assembled with the grating complete with accessories	Weight kg	Load class
1,000	4F00SPS	EVO series channel with galvanised edge rail, complete with 2 x GJS500-7 ductile iron inlay gratings	37.36	C 250
500	4F05SPS	EVO series channel with galvanised edge rail, complete with GJS500-7 ductile iron inlay grating	18.68	C 250

Vibro-Base 100 EVO Series accessories

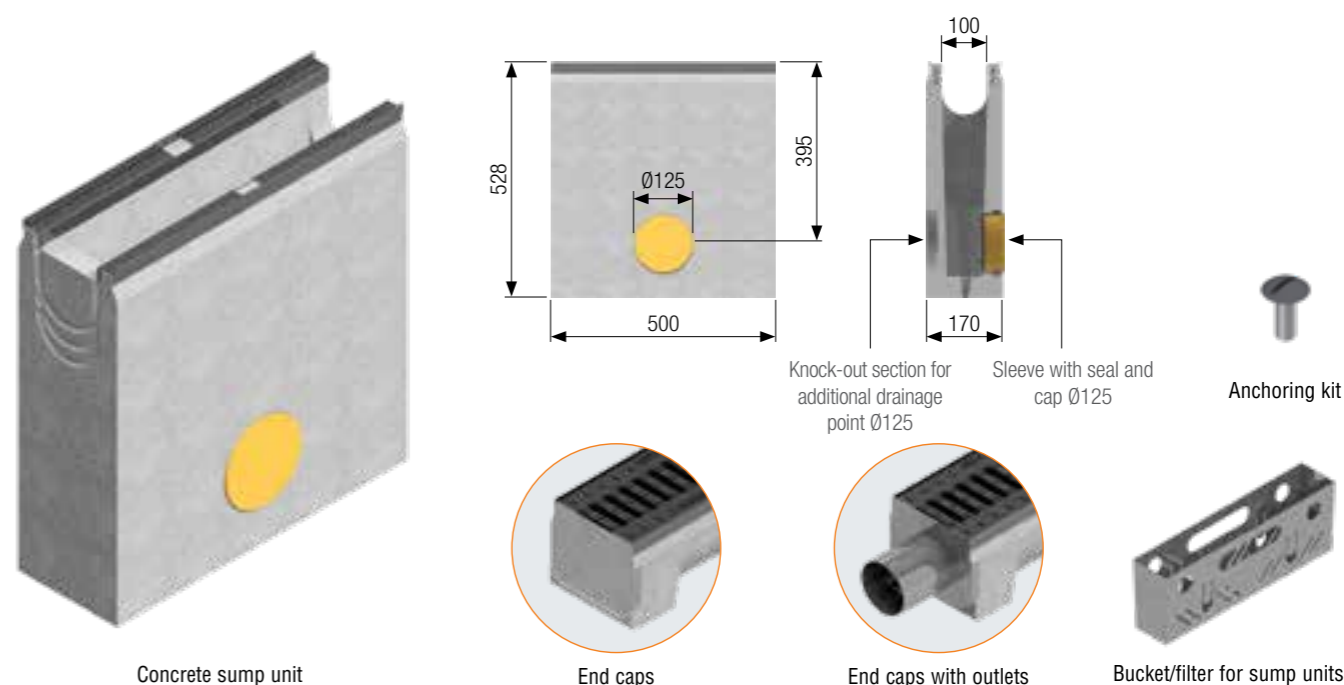

Vibro-Base 100 EVO Series concrete sump unit complete with grating - Length 500 mm

Sump unit L mm	Code	Description of the sump unit assembled with the grating complete with accessories	Weight kg	Load class
500	4F00SPZGS	Sump unit with galvanised edge rail, complete with GJS500-7 ductile iron inlay grating	64.33	C 250

Vibro-Base 100 EVO Series concrete sump unit without grating and accessories

Code	Description	Weight kg
4F00SPZ	Reinforced concrete sump unit with galvanised edge rail L 500 mm	60.93
4R01VI	Bucket/Filter, AISI 304 stainless steel	1.16
4F00TI	End cap for channel H 150	0.28
4F01TI	End cap for channel H 175	0.33
4F02TI	End cap for channel H 200	0.38
4F00RI	End cap with outlet drainage pipe diam. 89 mm for channel H 150	0.58
4F01RI	End cap with outlet drainage pipe diam. 89 mm for channel H 175	0.63
4F02RI	End cap with outlet drainage pipe diam. 89 mm for channel H 200	0.68
4510K	Kit for anchoring the grating to the channel and sump unit	0.024
	Channel bottom drilling Ø82 mm	

VIBRO-COMPRESSED CONCRETE CHANNELS VIBRO-BASE 100 SERIES WITH THIN COVER

CENTRAL SLOT

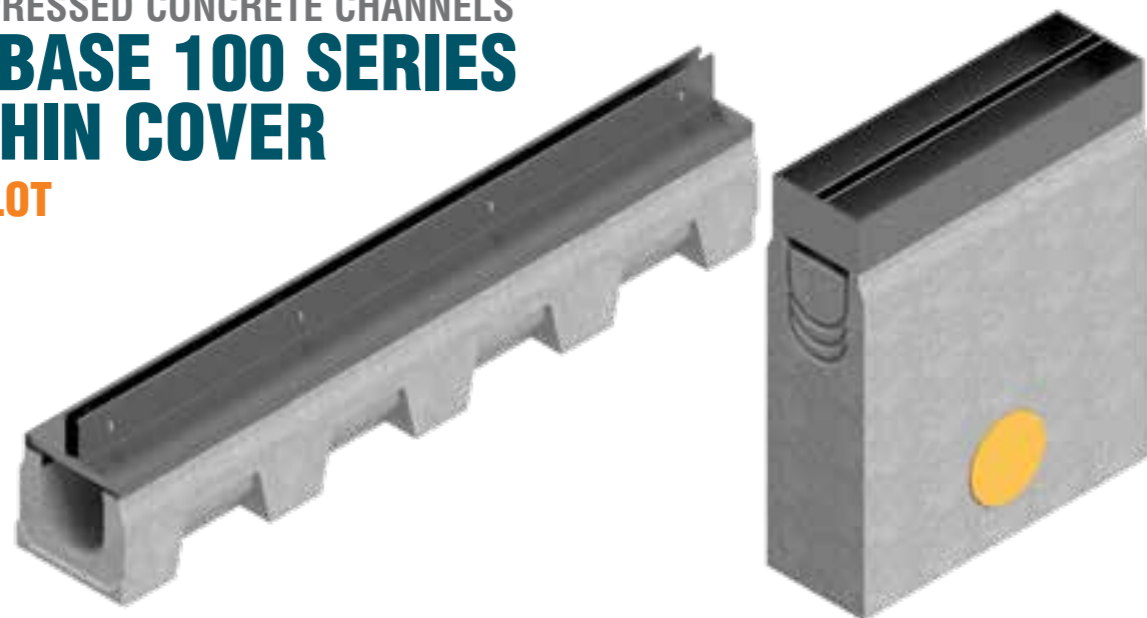

Vibro-Base 100 Series channel dimensions

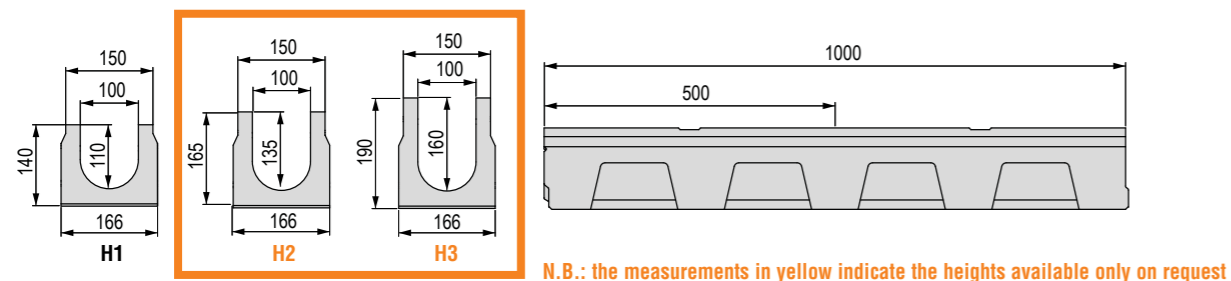

Available Thin covers

N.B.: available on request with 10 mm heelguard slot and in AISI 316 stainless steel

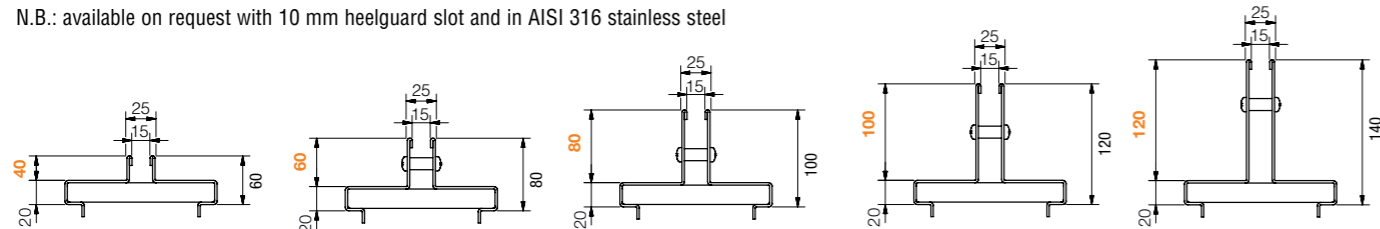

Vibro-Base 100 Series channel without grating - Length 1,000 / 500 mm

Channel L mm	Code	Description	Water passage mm	Run-off section cm ²	Weight kg	Pieces pallet
1,000	4F00S	Vibro-compressed concrete channel H1	100	99	27.74	loose
	4F01S	Vibro-compressed concrete channel H2	100	124	31.17	loose
	4F02S	Vibro-compressed concrete channel H3	100	149	33.60	loose
500	4F05S	Vibro-compressed concrete channel H1	100	99	13.87	loose
	4F06S	Vibro-compressed concrete channel H2	100	124	15.92	loose
	4F07S	Vibro-compressed concrete channel H3	100	149	16.80	loose

Vibro-Base 100 Series concrete sump unit without grating

Sump unit L mm	Code	Description	Weight kg
500	4F00PZ	Reinforced concrete sump unit	60.20

Thin covers with central slot - Slot width 15 mm

GALVANISED

Cover L mm	Code	Description	Slot height mm	Weight kg	Load class
1,000	4F00T0	Thin central cover, hot-dip galvanised, Th. 20/10	40	5.70	C 250
	4F00T	Thin central cover, hot-dip galvanised, Th. 20/10	60	6.33	
	4F00T1	Thin central cover, hot-dip galvanised, Th. 20/10	80	6.96	D 400
	4F00T2	Thin central cover, hot-dip galvanised, Th. 20/10	100	7.58	
	4F00T3	Thin central cover, hot-dip galvanised, Th. 20/10	120	8.21	
500	4F05T0	Thin central cover, hot-dip galvanised, Th. 20/10	40	2.85	C 250
	4F05T	Thin central cover, hot-dip galvanised, Th. 20/10	60	3.16	
	4F05T1	Thin central cover, hot-dip galvanised, Th. 20/10	80	3.48	D 400
	4F05T2	Thin central cover, hot-dip galvanised, Th. 20/10	100	3.79	
	4F05T3	Thin central cover, hot-dip galvanised, Th. 20/10	120	4.11	

N.B.: the Thin cover is supplied loose

AISI 304 STAINLESS STEEL

Cover L mm	Code	Description	Slot height mm	Weight kg	Load class
1,000	4F00I0	Thin central cover, AISI 304 stainless steel, Th. 20/10	40	5.70	C 250
	4F00I	Thin central cover, AISI 304 stainless steel, Th. 20/10	60	6.33	
	4F00I1	Thin central cover, AISI 304 stainless steel, Th. 20/10	80	6.96	D 400
	4F00I2	Thin central cover, AISI 304 stainless steel, Th. 20/10	100	7.58	
	4F00I3	Thin central cover, AISI 304 stainless steel, Th. 20/10	120	8.21	
500	4F05I0	Thin central cover, AISI 304 stainless steel, Th. 20/10	40	2.85	C 250
	4F05I	Thin central cover, AISI 304 stainless steel, Th. 20/10	60	3.16	
	4F05I1	Thin central cover, AISI 304 stainless steel, Th. 20/10	80	3.48	D 400
	4F05I2	Thin central cover, AISI 304 stainless steel, Th. 20/10	100	3.79	
	4F05I3	Thin central cover, AISI 304 stainless steel, Th. 20/10	120	4.11	

N.B.: the Thin cover is supplied loose

Inspection buckets for Thin covers with central slot - Slot width 15 mm

GALVANISED

Bucket L mm	Code	Description	Slot height mm	Weight kg	Load class
500	4F05V0	Inspection bucket for galvanised Thin central cover	40	4.42	C 250
	4F05V	Inspection bucket for galvanised Thin central cover	60	5.14	
	4F05V1	Inspection bucket for galvanised Thin central cover	80	5.86	D 400
	4F05V2	Inspection bucket for galvanised Thin central cover	100	6.57	
	4F05V3	Inspection bucket for galvanised Thin central cover	120	7.29	

N.B.: the Thin bucket is supplied loose

AISI 304 STAINLESS STEEL

Bucket L mm	Code	Description	Slot height mm	Weight kg	Load class
500	4F05VI0	Inspection bucket for Thin central cover made of AISI 304 stainless steel	40	4.42	C 250
	4F05VI	Inspection bucket for Thin central cover made of AISI 304 stainless steel	60	5.14	
	4F05VI1	Inspection bucket for Thin central cover made of AISI 304 stainless steel	80	5.86	D 400
	4F05VI2	Inspection bucket for Thin central cover made of AISI 304 stainless steel	100	6.57	
	4F05VI3	Inspection bucket for Thin central cover made of AISI 304 stainless steel	120	7.29	

N.B.: the Thin bucket is supplied loose

VIBRO-COMPRESSED CONCRETE CHANNELS VIBRO-BASE 100 SERIES WITH THIN COVER

SIDE SLOT

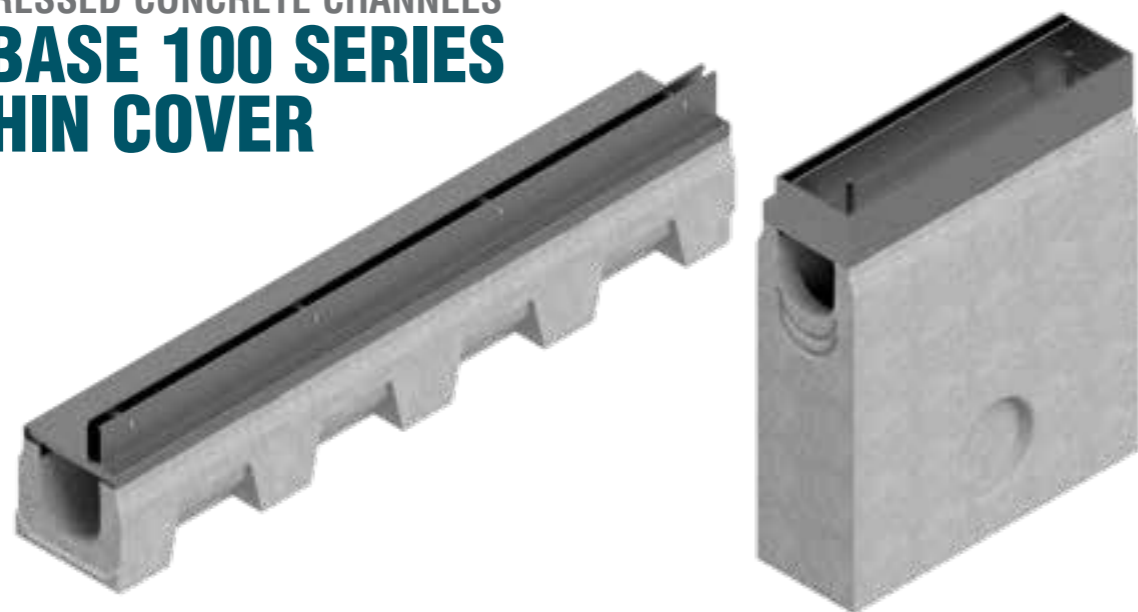

Vibro-Base 100 Series channel dimensions

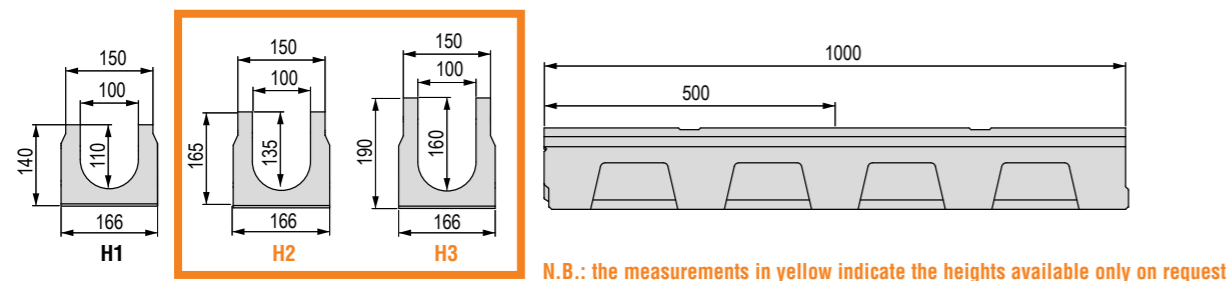

Available Thin covers

N.B.: available on request with 10 mm heelguard slot and in AISI 316 stainless steel

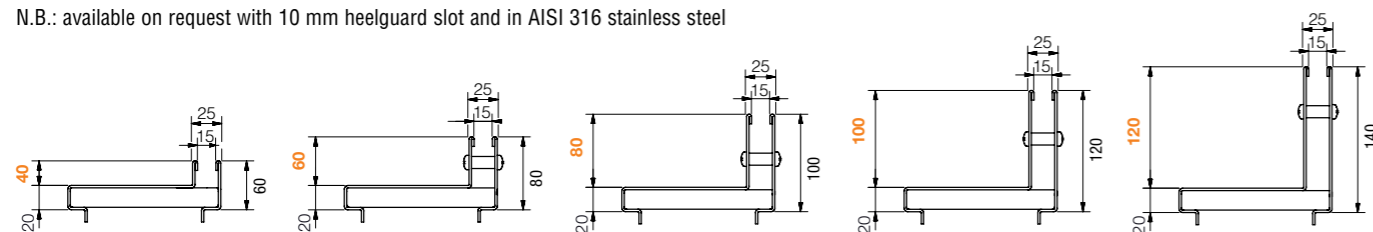

Vibro-Base 100 Series channel without grating - Length 1,000 / 500 mm

Channel L mm	Code	Description	Water passage mm	Run-off section cm ²	Weight kg	Pieces pallet
1,000	4F00S	Vibro-compressed concrete channel H1	100	99	27.74	loose
	4F01S	Vibro-compressed concrete channel H2	100	124	31.17	loose
	4F02S	Vibro-compressed concrete channel H3	100	149	33.60	loose
500	4F05S	Vibro-compressed concrete channel H1	100	99	13.87	loose
	4F06S	Vibro-compressed concrete channel H2	100	124	15.92	loose
	4F07S	Vibro-compressed concrete channel H3	100	149	16.80	loose

Vibro-Base 100 Series concrete sump unit without grating

Sump unit L mm	Code	Description	Weight kg
500	4F00PZ	Reinforced concrete sump unit	60.20

Thin covers with side slot - Slot width 15 mm

GALVANISED

Cover L mm	Code	Description	Slot height mm	Weight kg	Load class
1,000	4F00L0	Thin side cover, hot-dip galvanised, Th. 20/10	40	5.70	C 250
	4F00L	Thin side cover, hot-dip galvanised, Th. 20/10	60	6.33	
	4F00L1	Thin side cover, hot-dip galvanised, Th. 20/10	80	6.96	D 400
	4F00L2	Thin side cover, hot-dip galvanised, Th. 20/10	100	7.58	
	4F00L3	Thin side cover, hot-dip galvanised, Th. 20/10	120	8.21	
500	4F05L0	Thin side cover, hot-dip galvanised, Th. 20/10	40	2.85	C 250
	4F05L	Thin side cover, hot-dip galvanised, Th. 20/10	60	3.16	
	4F05L1	Thin side cover, hot-dip galvanised, Th. 20/10	80	3.48	D 400
	4F05L2	Thin side cover, hot-dip galvanised, Th. 20/10	100	3.79	
	4F05L3	Thin side cover, hot-dip galvanised, Th. 20/10	120	4.11	

N.B.: the Thin cover is supplied loose

AISI 304 STAINLESS STEEL

Cover L mm	Code	Description	Slot height mm	Weight kg	Load class
1,000	4F00IL0	Thin side cover, AISI 304 stainless steel, Th. 20/10	40	5.70	C 250
	4F00IL	Thin side cover, AISI 304 stainless steel, Th. 20/10	60	6.33	
	4F00IL1	Thin side cover, AISI 304 stainless steel, Th. 20/10	80	6.96	D 400
	4F00IL2	Thin side cover, AISI 304 stainless steel, Th. 20/10	100	7.58	
	4F00IL3	Thin side cover, AISI 304 stainless steel, Th. 20/10	120	8.21	
500	4F05IL0	Thin side cover, AISI 304 stainless steel, Th. 20/10	40	2.85	C 250
	4F05IL	Thin side cover, AISI 304 stainless steel, Th. 20/10	60	3.16	
	4F05IL1	Thin side cover, AISI 304 stainless steel, Th. 20/10	80	3.48	D 400
	4F05IL2	Thin side cover, AISI 304 stainless steel, Th. 20/10	100	3.79	
	4F05IL3	Thin side cover, AISI 304 stainless steel, Th. 20/10	120	4.11	

N.B.: the Thin cover is supplied loose

Inspection buckets for Thin covers with side slot - Slot width 15 mm

GALVANISED

Bucket L mm	Code	Description	Slot height mm	Weight kg	Load class
500	4F05VL0	Inspection bucket for galvanised Thin side cover	40	4.42	C 250
	4F05VL	Inspection bucket for galvanised Thin side cover	60	5.14	
	4F05VL1	Inspection bucket for galvanised Thin side cover	80	5.86	D 400
	4F05VL2	Inspection bucket for galvanised Thin side cover	100	6.57	
	4F05VL3	Inspection bucket for galvanised Thin side cover	120	7.29	

N.B.: the Thin bucket is supplied loose

AISI 304 STAINLESS STEEL

Bucket L mm	Code	Description	Slot height mm	Weight kg	Load class
500	4F05VLI0	Inspection bucket for Thin side cover made of AISI 304 stainless steel	40	4.42	C 250
	4F05VLI	Inspection bucket for Thin side cover made of AISI 304 stainless steel	60	5.14	
	4F05VLI1	Inspection bucket for Thin side cover made of AISI 304 stainless steel	80	5.86	D 400
	4F05VLI2	Inspection bucket for Thin side cover made of AISI 304 stainless steel	100	6.57	
	4F05VLI3	Inspection bucket for Thin side cover made of AISI 304 stainless steel	120	7.29	

N.B.: the Thin bucket is supplied loose

VIBRO-COMPRESSED CONCRETE CHANNELS

VIBRO-BASE 150 SERIES

Grating width 200 mm

Vibro-compressed concrete channel.
The channels are sold exclusively in complete pallets and together with the gratings.



Vibro-Base 150 Series channel dimensions

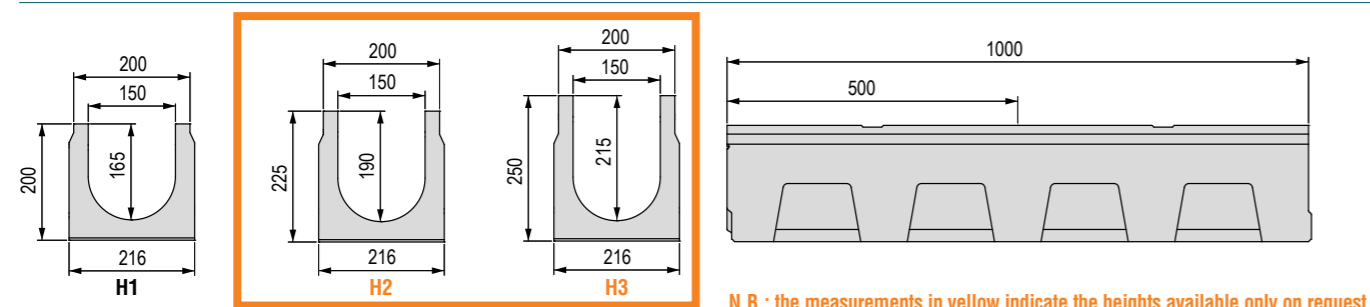

Available gratings



Vibro-Base 150 Series channel complete with grating - Length 1,000 / 500 mm

Channel L mm	Code	Grating	Description of the H1 channel assembled with the grating complete with accessories	Weight kg	Load class
1,000	4F10SGL	①	Channel complete with self-locking inlay grating made of galvanised press-formed metal sheet, 8 mm slots, 15/10	47.17	A 15
	4F10SGLI	②	Channel complete with self-locking inlay grating made of AISI 304 stainless steel press-formed metal sheet, 8 mm slots, 12/10	48.10	
	4F10SA	③	Channel complete with pressure-locked inlay grating 20x2-10x2 33x33, hot-dip galvanised	47.15	
	4F10SAA	④	Channel complete with pressure-locked heelguard inlay grating 20x2-10x2 55x11, hot-dip galvanised	47.80	B 125
	4F10SB	⑤	Channel complete with pressure-locked inlay grating 30x2-10x2 33x33, hot-dip galvanised	48.60	
	4F10SBA	⑥	Channel complete with pressure-locked heelguard inlay grating 30x2-10x2 55x11, hot-dip galvanised	49.15	
	4F10SGS	⑦	Channel complete with 2 x GJS500-7 ductile iron inlay gratings	55.96	
500	4F15SGL	①	Channel complete with self-locking inlay grating made of galvanised press-formed metal sheet, 8 mm slots, 15/10	23.59	A 15
	4F15SGLI	②	Channel complete with self-locking inlay grating made of AISI 304 stainless steel press-formed metal sheet, 8 mm slots, 12/10	24.50	
	4F15SA	③	Channel complete with pressure-locked inlay grating 20x2-10x2 33x33, hot-dip galvanised	23.58	
	4F15SAA	④	Channel complete with pressure-locked heelguard inlay grating 20x2-10x2 55x11, hot-dip galvanised	23.90	B 125
	4F15SB	⑤	Channel complete with pressure-locked inlay grating 30x2-10x2 33x33, hot-dip galvanised	24.30	
	4F15SBA	⑥	Channel complete with pressure-locked heelguard inlay grating 30x2-10x2 55x11, hot-dip galvanised	24.58	
	4F15SGS	⑦	Channel complete with GJS500-7 ductile iron inlay grating	27.98	

Vibro-Base 150 Series accessories

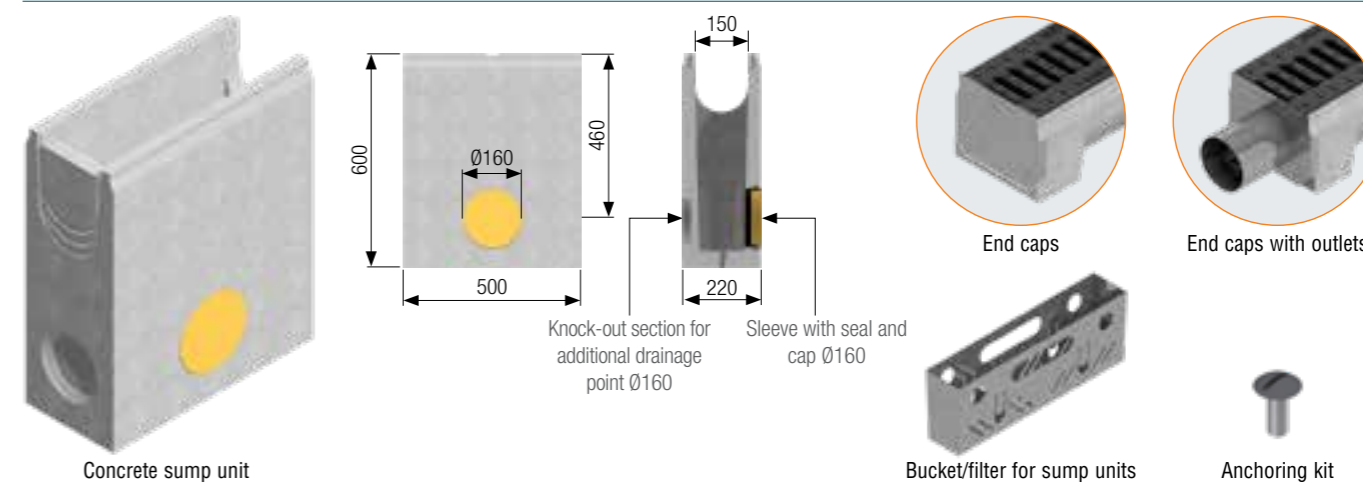

Vibro-Base 150 Series concrete sump unit complete with grating - Length 500 mm

Sump unit L mm	Code	Grating	Description of the sump unit assembled with the grating complete with accessories	Weight kg	Load class
500	4F10PZGL	①	Sump unit complete with self-locking inlay grating in press-formed metal sheet, galvanised, 8 mm slots, 15/10	74.05	A 15
	4F10PZGLI	②	Sump unit complete with self-locking inlay grating made of AISI 304 stainless steel press-formed metal sheet, 8 mm slots, 12/10	75.08	
	4F10PZA	③	Sump unit complete with pressure-locked inlay grating 20x2-10x2 33x33, hot-dip galvanised	73.87	
	4F10PZAA	④	Sump unit complete with pressure-locked heelguard inlay grating 20x2-10x2 55x11, hot-dip galvanised	74.34	B 125
	4F10PZB	⑤	Sump unit complete with pressure-locked inlay grating 30x2-10x2 33x33, hot-dip galvanised	74.9	
	4F10PZBA	⑥	Sump unit complete with pressure-locked heelguard inlay grating 30x2-10x2 55x11, hot-dip galvanised	75.07	
	4F10PZGS	⑦	Sump unit complete with GJS500-7 ductile iron inlay grating	78.38	

Vibro-Base 150 Series concrete sump unit without grating and accessories

Code	Description	Weight kg
4F10PZ	Reinforced concrete sump unit L 500 mm	72.25
4R02VI	Bucket/Filter, AISI 304 stainless steel	1.50
4F10TI	End cap h200	0.51
4F11TI	End cap h225	0.58
4F12TI	End cap h250	0.65
4F10RI	End cap with outlet drainage pipe diam. 156 mm for channel h200	1.34
4F11RI	End cap with outlet drainage pipe diam. 156 mm for channel h225	1.41
4F12RI	End cap with outlet drainage pipe diam. 156 mm for channel h250	1.48
4510K	Kit for anchoring the grating to the channel and sump unit	0.024
	Channel bottom drilling Ø132 mm	

Vibro-Base 150 Series channel without grating - Length 1,000 / 500 mm

Channel L mm	Code	Description	Water passage mm	Run-off section cm ²	Weight kg	Pieces pallet
1,000	4F10S	Vibro-compressed concrete channel H1	150	223	43.62	25
	4F11S	Vibro-compressed concrete channel H2	150	261	46.85	25
	4F12S	Vibro-compressed concrete channel H3	150	298	48.35	25
500	4F15S	Vibro-compressed concrete channel H1	150	223	21.81	loose
	4F16S	Vibro-compressed concrete channel H2	150	261	23.43	loose
	4F17S	Vibro-compressed concrete channel H3	150	298	24.2	loose

VIBRO-COMPRESSED CONCRETE CHANNELS

VIBRO-BASE 150 EVO SERIES

(with edge rail)

Grating width 200 mm

Vibro-compressed concrete channel with galvanised protective edge rails. The channels are sold exclusively in complete pallets and together with the gratings.

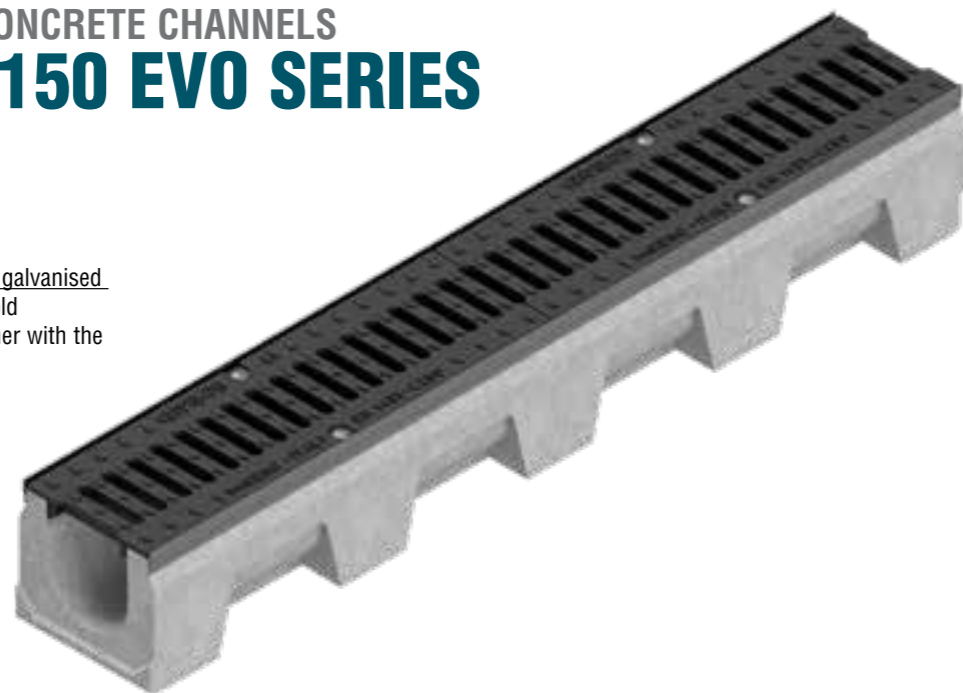

Vibro-Base 150 EVO Series channel dimensions

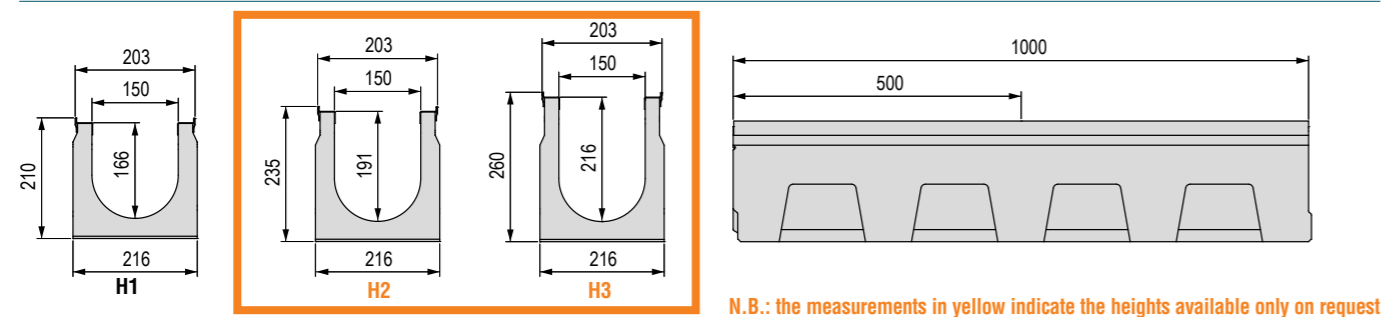

Available grating

GJS500-7 ductile iron inlay grating
C 250



Vibro-Base 150 EVO Series channel complete with grating - Length 1,000 / 500 mm

Channel L mm	Code	Description of the H1 channel assembled with the grating complete with accessories	Weight kg	Load class
1,000	4F10SPS	EVO Series channel with galvanised edge rail, complete with 2 x GJS500-7 ductile iron inlay gratings	57.96	C 250
500	4F15SPS	EVO Series channel with galvanised edge rail, complete with GJS500-7 ductile iron inlay grating	28.98	C 250

Vibro-Base 150 EVO Series accessories

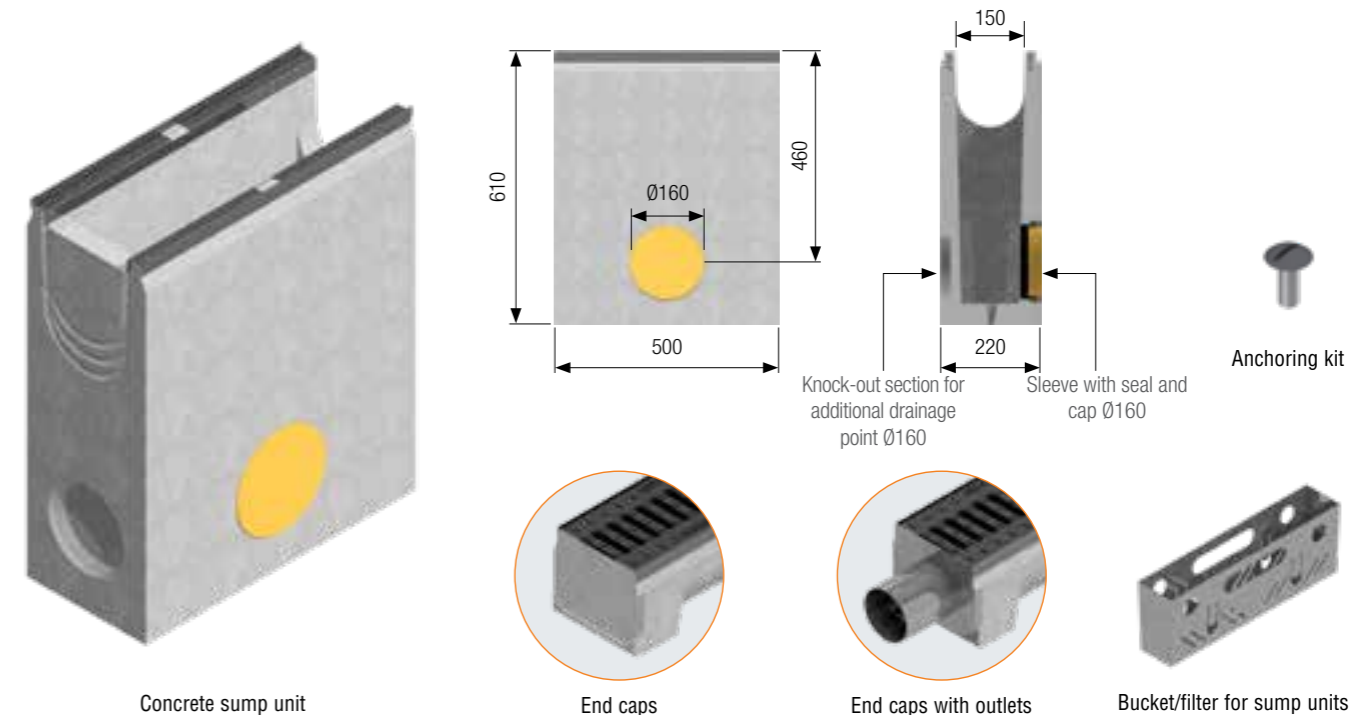

Vibro-Base 150 EVO Series concrete sump unit complete with grating - Length 500 mm

Sump unit L mm	Code	Description of the sump unit assembled with the grating complete with accessories	Weight kg	Load class
500	4F10SPZGS	Sump unit with galvanised edge rail, complete with GJS500-7 ductile iron inlay grating	79.11	C 250

Vibro-Base 150 EVO Series concrete sump unit without grating and accessories

Code	Description	Weight kg
4F10SPZ	Reinforced concrete sump unit with galvanised edge rail L 500 mm	72.98
4R02VI	Bucket/Filter, AISI 304 stainless steel	1.50
4F10TI	End cap for channel H 210	0.51
4F11TI	End cap for channel H 235	0.58
4F12TI	End cap for channel H 260	0.65
4F10RI	End cap with outlet drainage pipe diam. 156 mm for channel H 210	1.34
4F11RI	End cap with outlet drainage pipe diam. 156 mm for channel H 235	1.41
4F12RI	End cap with outlet drainage pipe diam. 156 mm for channel H 260	1.48
4510K	Kit for anchoring the grating to the channel and sump unit	0.024
	Channel bottom drilling Ø132 mm	

VIBRO-COMPRESSED CONCRETE CHANNELS

VIBRO-BASE 150 SERIES

WITH THIN COVER

CENTRAL SLOT



Vibro-Base 150 Series channel dimensions

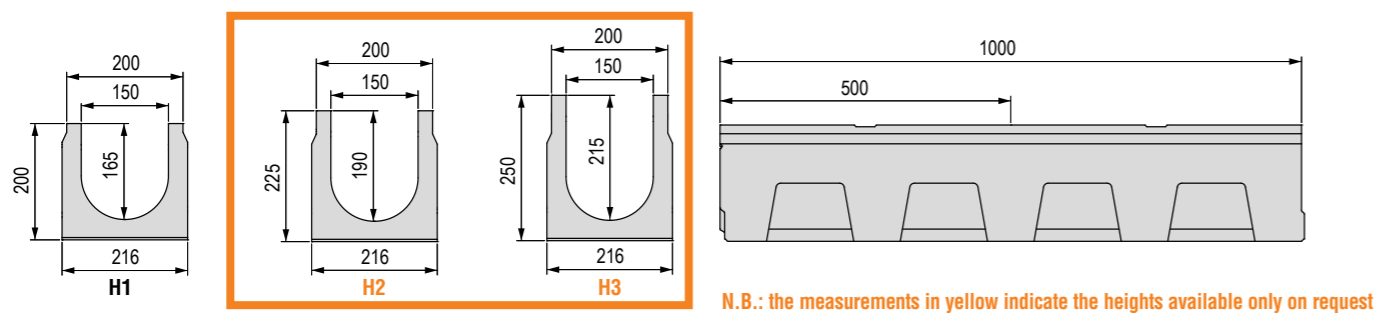

Available Thin covers

N.B.: available on request with 10 mm heelguard slot and in AISI 316 stainless steel

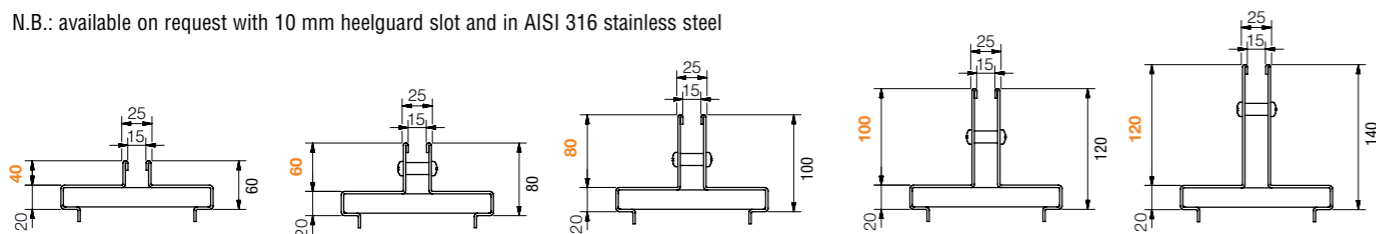

Vibro-Base 150 Series channel without grating - Length 1,000 / 500 mm

Channel L mm	Code	Description	Water passage mm	Run-off section cm ²	Weight kg	Pieces pallet
1,000	4F10S	Vibro-compressed concrete channel H1	150	223	43.62	loose
	4F11S	Vibro-compressed concrete channel H2	150	261	46.85	loose
	4F12S	Vibro-compressed concrete channel H3	150	298	48.35	loose
500	4F15S	Vibro-compressed concrete channel H1	150	223	21.81	loose
	4F16S	Vibro-compressed concrete channel H2	150	261	23.43	loose
	4F17S	Vibro-compressed concrete channel H3	150	298	24.2	loose

Vibro-Base 150 Series concrete sump unit without grating

Sump unit L mm	Code	Description	Weight kg
500	4F10PZ	Reinforced concrete sump unit L 500 mm	72.25

Thin covers with central slot - Slot width 15 mm

GALVANISED

Cover L mm	Code	Description	Slot height mm	Weight kg	Load class
1,000	4F10T0	Thin central cover, hot-dip galvanised, Th. 20/10	40	6.73	C 250
	4F10T	Thin central cover, hot-dip galvanised, Th. 20/10	60	7.36	
	4F10T1	Thin central cover, hot-dip galvanised, Th. 20/10	80	7.99	D 400
	4F10T2	Thin central cover, hot-dip galvanised, Th. 20/10	100	8.61	
	4F10T3	Thin central cover, hot-dip galvanised, Th. 20/10	120	9.24	
500	4F15T0	Thin central cover, hot-dip galvanised, Th. 20/10	40	3.37	C 250
	4F15T	Thin central cover, hot-dip galvanised, Th. 20/10	60	3.68	
	4F15T1	Thin central cover, hot-dip galvanised, Th. 20/10	80	4.00	D 400
	4F15T2	Thin central cover, hot-dip galvanised, Th. 20/10	100	4.31	
	4F15T3	Thin central cover, hot-dip galvanised, Th. 20/10	120	4.62	

N.B.: the Thin cover is supplied loose

AISI 304 STAINLESS STEEL

Cover L mm	Code	Description	Slot height mm	Weight kg	Load class
1,000	4F10I0	Thin central cover, AISI 304 stainless steel, Th. 20/10	40	6.73	C 250
	4F10I	Thin central cover, AISI 304 stainless steel, Th. 20/10	60	7.36	
	4F10I1	Thin central cover, AISI 304 stainless steel, Th. 20/10	80	7.99	D 400
	4F10I2	Thin central cover, AISI 304 stainless steel, Th. 20/10	100	8.61	
	4F10I3	Thin central cover, AISI 304 stainless steel, Th. 20/10	120	9.24	
500	4F15I0	Thin central cover, AISI 304 stainless steel, Th. 20/10	40	3.37	C 250
	4F15I	Thin central cover, AISI 304 stainless steel, Th. 20/10	60	3.68	
	4F15I1	Thin central cover, AISI 304 stainless steel, Th. 20/10	80	4.00	D 400
	4F15I2	Thin central cover, AISI 304 stainless steel, Th. 20/10	100	4.31	
	4F15I3	Thin central cover, AISI 304 stainless steel, Th. 20/10	120	4.62	

N.B.: the Thin cover is supplied loose

Inspection buckets for Thin covers with central slot - Slot width 15 mm

GALVANISED

Bucket L mm	Code	Description	Slot height mm	Weight kg	Load class
500	4F15V0	Inspection bucket for galvanised Thin central cover	40	5.13	C 250
	4F15V	Inspection bucket for galvanised Thin central cover	60	5.88	
	4F15V1	Inspection bucket for galvanised Thin central cover	80	6.63	D 400
	4F15V2	Inspection bucket for galvanised Thin central cover	100	7.37	
	4F15V3	Inspection bucket for galvanised Thin central cover	120	8.12	

N.B.: the Thin bucket is supplied loose

AISI 304 STAINLESS STEEL

Bucket L mm	Code	Description	Slot height mm	Weight kg	Load class
500	4F15VI0	Inspection bucket for Thin central cover made of AISI 304 stainless steel	40	5.13	C 250
	4F15VI	Inspection bucket for Thin central cover made of AISI 304 stainless steel	60	5.88	
	4F15VI1	Inspection bucket for Thin central cover made of AISI 304 stainless steel	80	6.63	D 400
	4F15VI2	Inspection bucket for Thin central cover made of AISI 304 stainless steel	100	7.37	
	4F15VI3	Inspection bucket for Thin central cover made of AISI 304 stainless steel	120	8.12	

N.B.: the Thin bucket is supplied loose

VIBRO-COMPRESSED CONCRETE CHANNELS VIBRO-BASE 150 SERIES WITH THIN COVER

SIDE SLOT

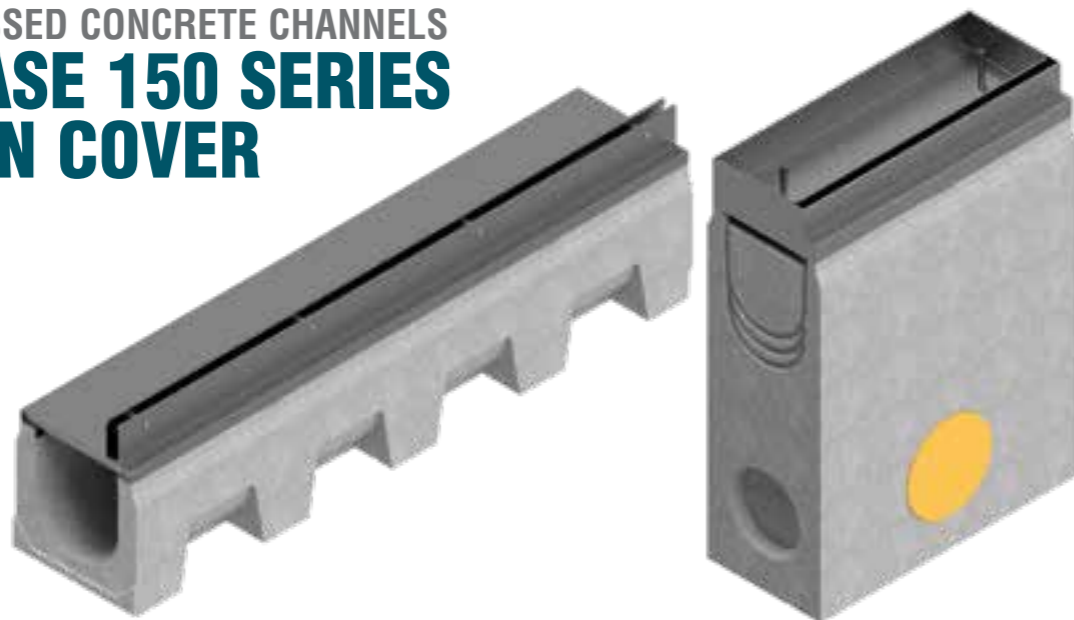

Vibro-Base 150 Series channel dimensions

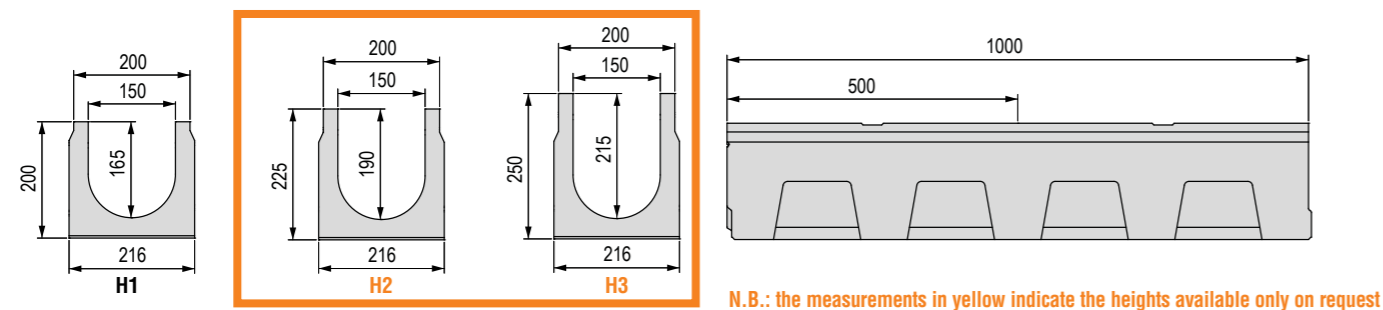

Available Thin covers

N.B.: available on request with 10 mm heelguard slot and in AISI 316 stainless steel

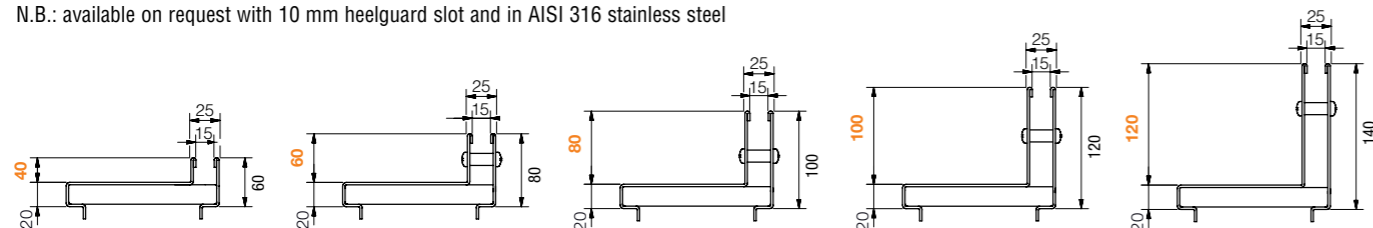

Vibro-Base 150 Series channel without grating - Length 1,000 / 500 mm

Channel L mm	Code	Description	Water passage mm	Run-off section cm ²	Weight kg	Pieces pallet
1,000	4F10S	Vibro-compressed concrete channel H1	150	223	43.62	loose
	4F11S	Vibro-compressed concrete channel H2	150	261	46.85	loose
	4F12S	Vibro-compressed concrete channel H3	150	298	48.35	loose
500	4F15S	Vibro-compressed concrete channel H1	150	223	21.81	loose
	4F16S	Vibro-compressed concrete channel H2	150	261	23.43	loose
	4F17S	Vibro-compressed concrete channel H3	150	298	24.2	loose

Vibro-Base 150 Series concrete sump unit without grating

Sump unit L mm	Code	Description	Weight kg
500	4F10PZ	Reinforced concrete sump unit L 500 mm	72.25



Thin covers with side slot - Slot width 15 mm

GALVANISED

Cover L mm	Code	Description	Slot height mm	Weight kg	Load class
1,000	4F10L0	Thin side cover, hot-dip galvanised, Th. 20/10	40	6.73	C 250
	4F10L	Thin side cover, hot-dip galvanised, Th. 20/10	60	7.36	
	4F10L1	Thin side cover, hot-dip galvanised, Th. 20/10	80	7.99	D 400
	4F10L2	Thin side cover, hot-dip galvanised, Th. 20/10	100	8.61	
	4F10L3	Thin side cover, hot-dip galvanised, Th. 20/10	120	9.24	
500	4F15L0	Thin side cover, hot-dip galvanised, Th. 20/10	40	3.37	C 250
	4F15L	Thin side cover, hot-dip galvanised, Th. 20/10	60	3.68	
	4F15L1	Thin side cover, hot-dip galvanised, Th. 20/10	80	4.00	D 400
	4F15L2	Thin side cover, hot-dip galvanised, Th. 20/10	100	4.31	
	4F15L3	Thin side cover, hot-dip galvanised, Th. 20/10	120	4.62	

N.B.: the Thin cover is supplied loose

AISI 304 STAINLESS STEEL

Cover L mm	Code	Description	Slot height mm	Weight kg	Load class
1,000	4F10IL0	Thin side cover, AISI 304 stainless steel, Th. 20/10	40	6.80	C 250
	4F10IL	Thin side cover, AISI 304 stainless steel, Th. 20/10	60	7.20	
	4F10IL1	Thin side cover, AISI 304 stainless steel, Th. 20/10	80	7.48	D 400
	4F10IL2	Thin side cover, AISI 304 stainless steel, Th. 20/10	100	8.10	
	4F10IL3	Thin side cover, AISI 304 stainless steel, Th. 20/10	120	8.74	
500	4F15IL0	Thin side cover, AISI 304 stainless steel, Th. 20/10	40	3.40	C 250
	4F15IL	Thin side cover, AISI 304 stainless steel, Th. 20/10	60	3.60	
	4F15IL1	Thin side cover, AISI 304 stainless steel, Th. 20/10	80	3.74	D 400
	4F15IL2	Thin side cover, AISI 304 stainless steel, Th. 20/10	100	4.05	
	4F15IL3	Thin side cover, AISI 304 stainless steel, Th. 20/10	120	4.37	

N.B.: the Thin cover is supplied loose



Inspection buckets for Thin covers with side slot - Slot width 15 mm

GALVANISED

Bucket L mm	Code	Description	Slot height mm	Weight kg	Load class
500	4F15VL0	Inspection bucket for galvanised Thin side cover	40	5.13	C 250
	4F15VL	Inspection bucket for galvanised Thin side cover	60	5.88	
	4F15VL1	Inspection bucket for galvanised Thin side cover	80	6.63	D 400
	4F15VL2	Inspection bucket for galvanised Thin side cover	100	7.37	
	4F15VL3	Inspection bucket for galvanised Thin side cover	120	8.12	

N.B.: the Thin bucket is supplied loose

AISI 304 STAINLESS STEEL

Bucket L mm	Code	Description	Slot height mm	Weight kg	Load class
500	4F15VL10	Inspection bucket for Thin side cover made of AISI 304 stainless steel	40	5.13	C 250
	4F15VLI	Inspection bucket for Thin side cover made of AISI 304 stainless steel	60	5.88	
	4F15VLI1	Inspection bucket for Thin side cover made of AISI 304 stainless steel	80	6.63	D 400
	4F15VLI2	Inspection bucket for Thin side cover made of AISI 304 stainless steel	100	7.37	
	4F15VLI3	Inspection bucket for Thin side cover made of AISI 304 stainless steel	120	8.12	

N.B.: the Thin bucket is supplied loose

VIBRO-COMPRESSED CONCRETE CHANNELS

VIBRO-BASE 200 SERIES

Grating width 250 mm

Vibro-compressed concrete channel.
The channels are sold exclusively in complete pallets and together with the gratings.

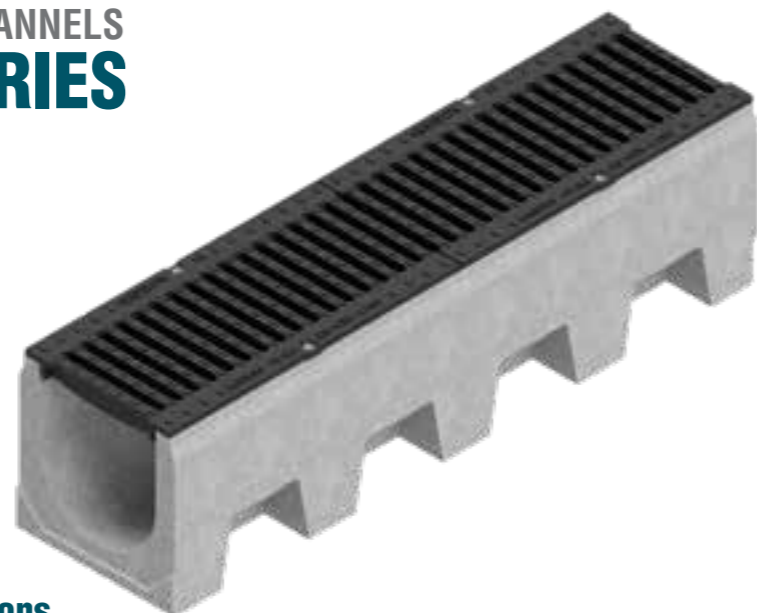

Vibro-Base 200 Series channel dimensions

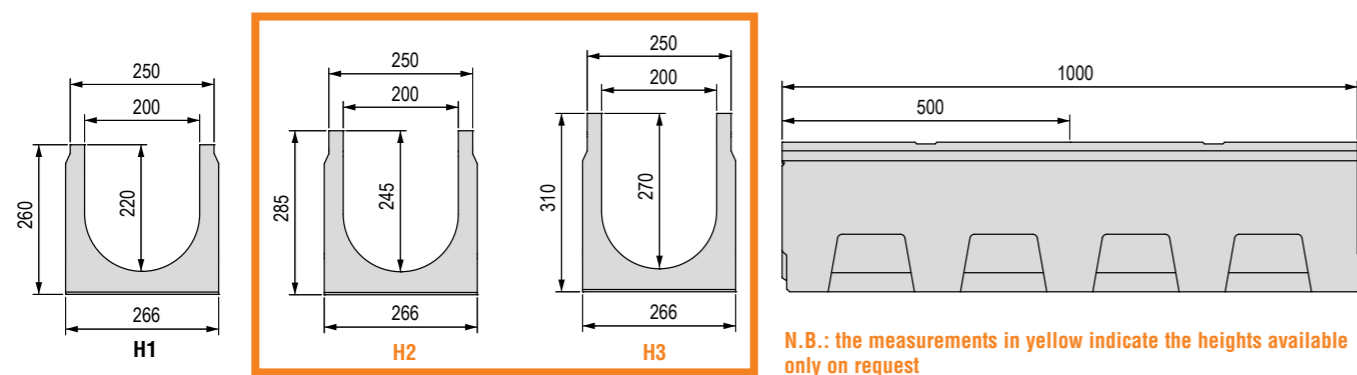

Available gratings



Vibro-Base 200 Series channel complete with grating - Length 1,000 / 500 mm

Channel L mm	Code	Grating	Description of the H1 channel assembled with the grating complete with accessories	Weight kg	Load class
1,000	4F20SA	①	Channel complete with pressure-locked inlay grating 30x2-10x2 33x33, hot-dip galvanised	66.03	A 15
	4F20SAA	②	Channel complete with pressure-locked heelguard inlay grating 30x2-10x2 55x11, hot-dip galvanised	66.96	
	4F20SB	③	Channel complete with pressure-locked inlay grating 40x2-10x2 33x33, hot-dip galvanised	67.64	B 125
	4F20SBA	④	Channel complete with pressure-locked inlay grating 40x2-10x2 55x11 heelguard mesh, hot-dip galvanised	68.16	
	4F20SGS	⑤	Channel complete with 2 x GJS500-7 ductile iron inlay gratings	81.86	C 250
500	4F25SA	①	Channel complete with pressure-locked inlay grating 30x2-10x2 33x33, hot-dip galvanised	33.02	A 15
	4F25SAA	②	Channel complete with pressure-locked heelguard inlay grating 30x2-10x2 55x11, hot-dip galvanised	33.48	
	4F25SB	③	Channel complete with pressure-locked inlay grating 40x2-10x2 33x33, hot-dip galvanised	33.82	B 125
	4F25SBA	④	Channel complete with pressure-locked heelguard inlay grating 40x2-10x2 55x11, hot-dip galvanised	34.08	
	4F25SGS	⑤	Channel complete with GJS500-7 ductile iron inlay grating	40.93	C 250

Vibro-Base 200 Series accessories

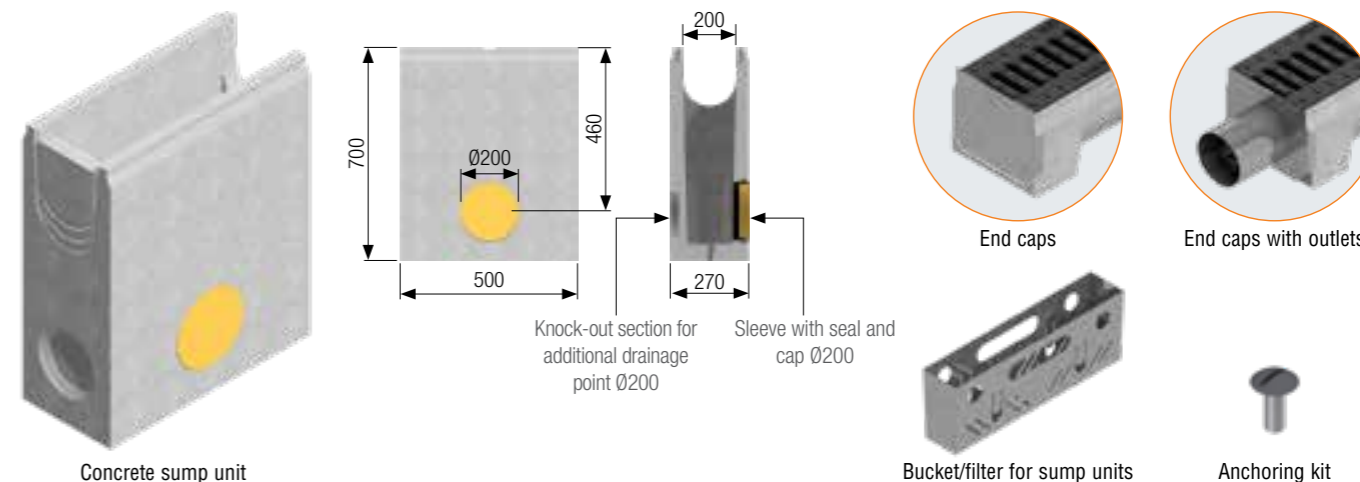

Vibro-Base 200 Series concrete sump unit complete with grating - Length 500 mm

Sump unit L mm	Code	Grating	Description of the sump unit assembled with the grating complete with accessories	Weight kg	Load class
500	4F20PZA	①	Sump unit complete with pressure-locked inlay grating 30x2-10x2 33x33, hot-dip galvanised	99.40	A 15
	4F20PZAA	②	Sump unit complete with pressure-locked heelguard inlay grating 30x2-10x2 55x11, hot-dip galvanised	99.93	
	4F20PZB	③	Sump unit complete with pressure-locked inlay grating 40x2-10x2 33x33, hot-dip galvanised	100.67	B 125
	4F20PZBA	④	Sump unit complete with pressure-locked heelguard inlay grating 40x2-10x2 55x11, hot-dip galvanised	100.67	
	4F20PZGS	⑤	Sump unit complete with GJS500-7 ductile iron inlay grating	107.44	C 250

Vibro-Base 200 Series concrete sump unit without grating and accessories

Code	Description	Weight kg
4F20PZ	Reinforced concrete sump unit L 500 mm	96.80
4R03VI	Bucket/Filter, AISI 304 stainless steel	1.71
4F20TI	End cap h260	1.07
4F21TI	End cap h285	1.14
4F22TI	End cap h310	1.21
4F20RI	End cap with outlet drainage pipe diam. 156 mm for channel h260	1.67
4F21RI	End cap with outlet drainage pipe diam. 156 mm for channel h285	1.74
4F22RI	End cap with outlet drainage pipe diam. 156 mm for channel h310	1.81
4510K	Kit for anchoring the grating to the channel and sump unit	0.024
	Channel bottom drilling Ø162 mm	

Vibro-Base 200 Series channel without grating - Length 1,000 / 500 mm

Channel L mm	Code	Description	Water passage mm	Run-off section cm ²	Weight kg	Pieces pallet
1,000	4F20S	Vibro-compressed concrete channel H1	200	397	60.50	16
	4F21S	Vibro-compressed concrete channel H2	200	447	62.03	16
	4F22S	Vibro-compressed concrete channel H3	200	497	63.55	16
500	4F25S	Vibro-compressed concrete channel H1	200	397	30.25	loose
	4F26S	Vibro-compressed concrete channel H2	200	447	31.12	loose
	4F27S	Vibro-compressed concrete channel H3	200	497	31.78	loose

VIBRO-COMPRESSED CONCRETE CHANNELS

VIBRO-BASE 200 EVO SERIES

(with edge rail)

Grating width 250 mm

Vibro-compressed concrete channel with galvanised protective edge rails. The channels are sold exclusively in complete pallets and together with the gratings.

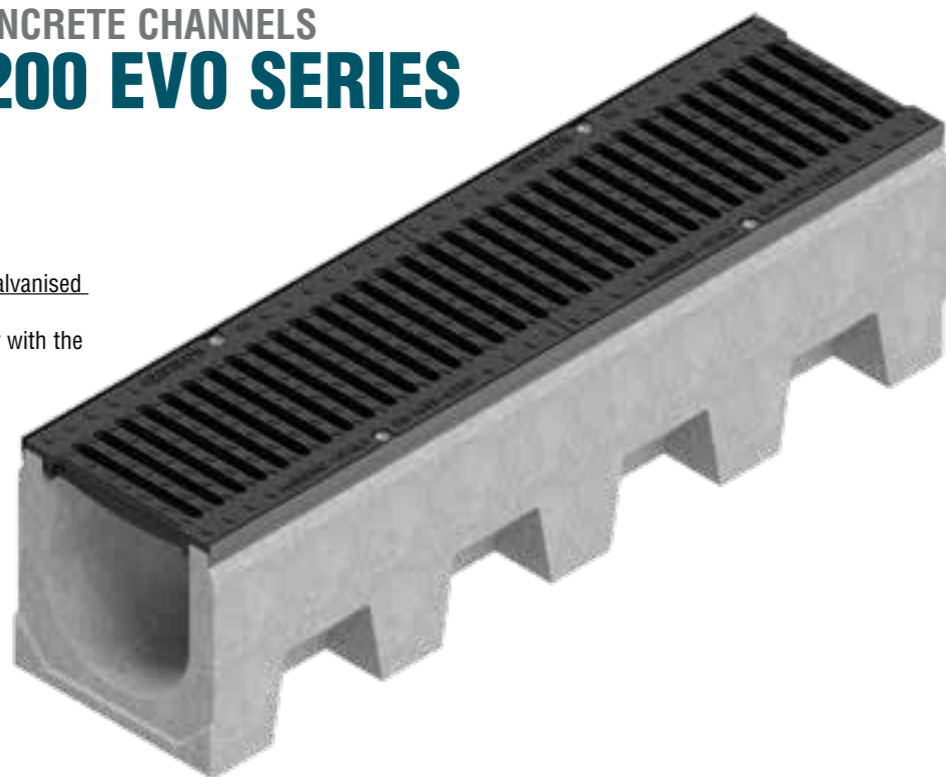

Vibro-Base 200 EVO Series channel dimensions

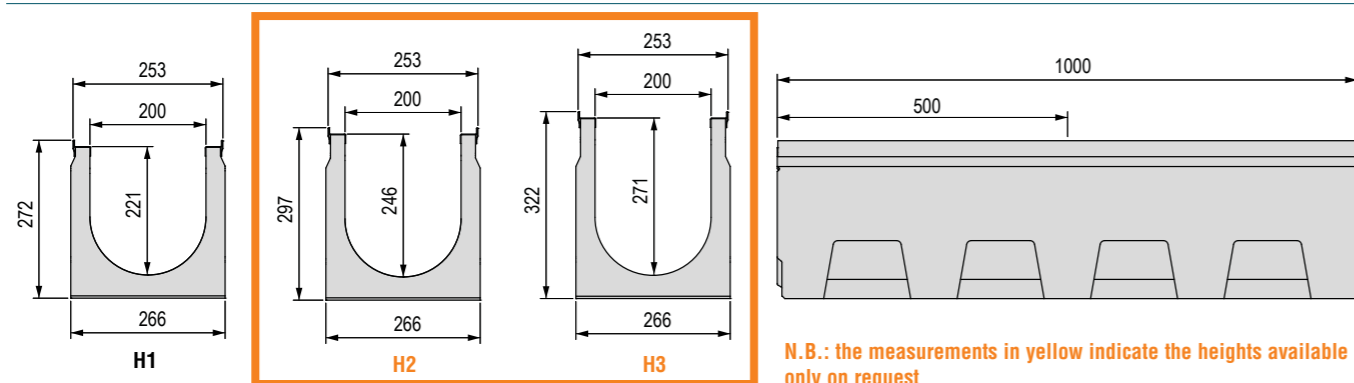

Available grating

GJS500-7 ductile iron inlay grating
C 250



Vibro-Base 200 EVO Series channel complete with grating - Length 1,000 / 500 mm

Channel L mm	Code	Description of the H1 channel assembled with the grating complete with accessories	Weight kg	Load class
1,000	4F20SPS	EVO Series channel with galvanised edge rail, complete with 2 x GJS500-7 ductile iron inlay gratings	83.86	C 250
500	4F25SPS	EVO Series channel with galvanised edge rail, complete with GJS500-7 ductile iron inlay grating	41.93	C 250

Vibro-Base 200 EVO Series accessories

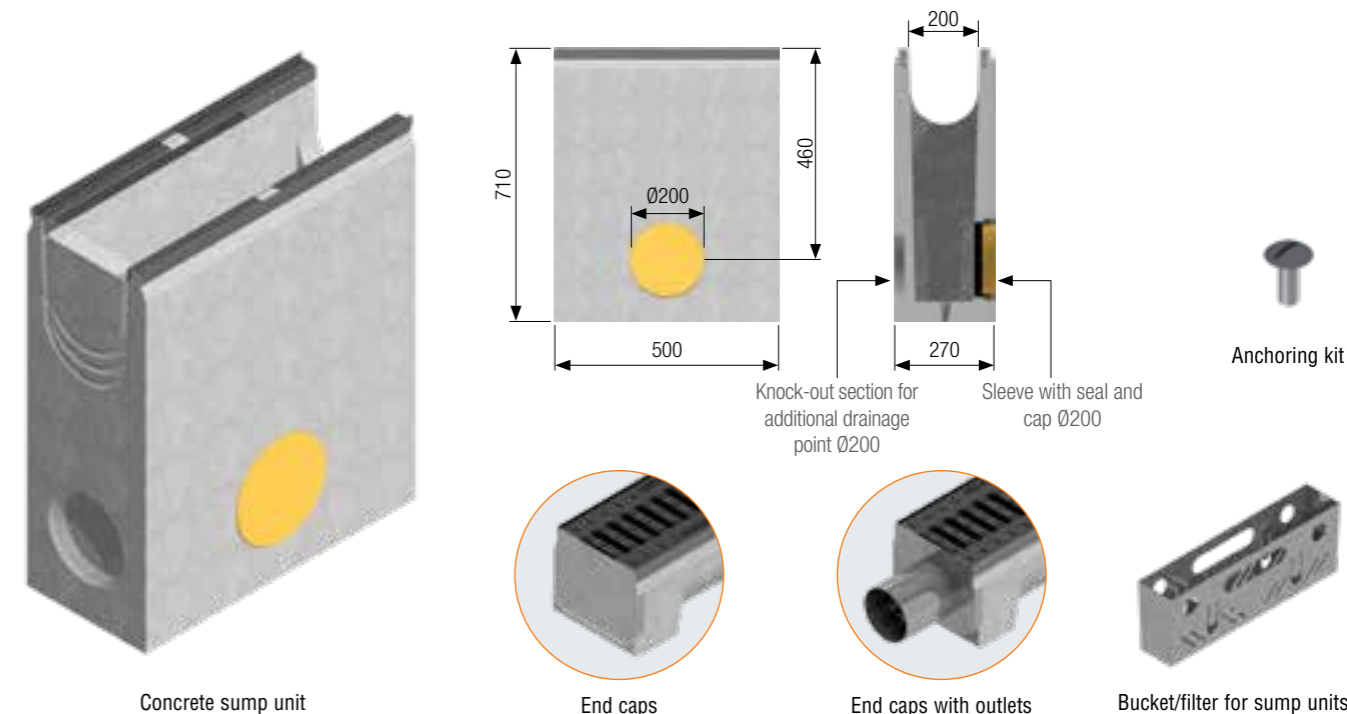

Vibro-Base 200 EVO Series sump unit with grating - Length 500 mm

Sump unit L mm	Code	Description of the sump unit assembled with the grating complete with accessories	Weight kg	Load class
500	4F20SPZGS	Sump unit with galvanised edge rail, complete with GJS500-7 ductile iron inlay grating	108.17	C 250

Vibro-Base 200 EVO Series concrete sump unit without grating and accessories

Code	Description	Weight kg
4F20SPZ	Reinforced concrete sump unit with galvanised edge rail L 500 mm	96.8
4R03VI	Bucket/Filter, AISI 304 stainless steel	1.71
4F20TI	End cap for channel H 272	1.07
4F21TI	End cap for channel H 297	1.14
4F22TI	End cap for channel H 322	1.21
4F20RI	End cap with outlet drainage pipe diam. 156 mm for channel H 272	1.67
4F21RI	End cap with outlet drainage pipe diam. 156 mm for channel H 297	1.74
4F22RI	End cap with outlet drainage pipe diam. 156 mm for channel H 322	1.81
4510K	Kit for anchoring the grating to the channel and sump unit	0.024
	Channel bottom drilling Ø162 mm	

VIBRO-COMPRESSED CONCRETE CHANNELS VIBRO-BASE 200 SERIES WITH THIN COVER CENTRAL SLOT

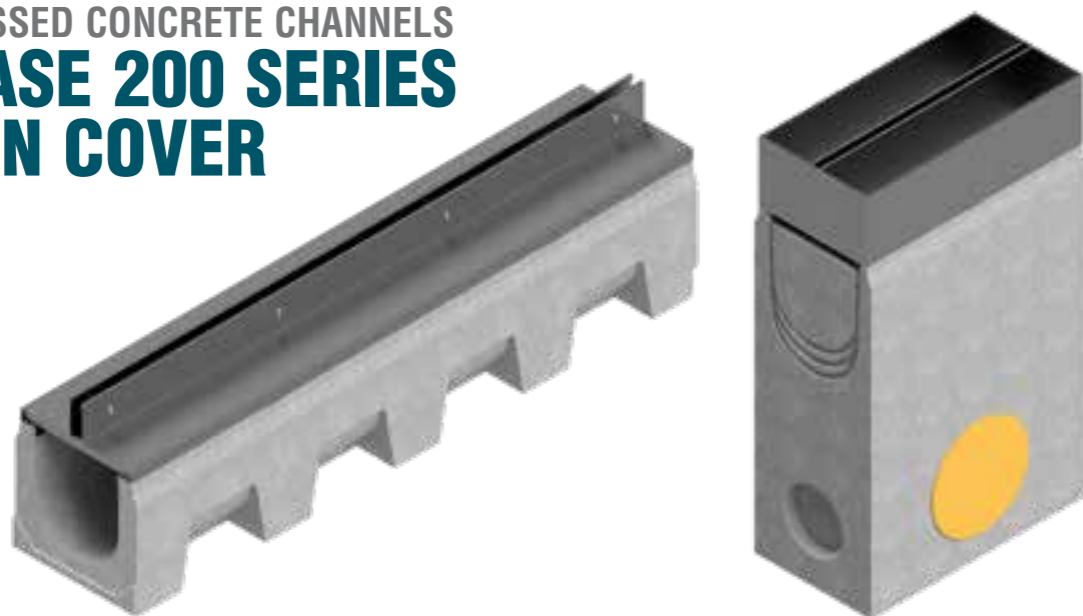

Vibro-Base 200 Series channel dimensions

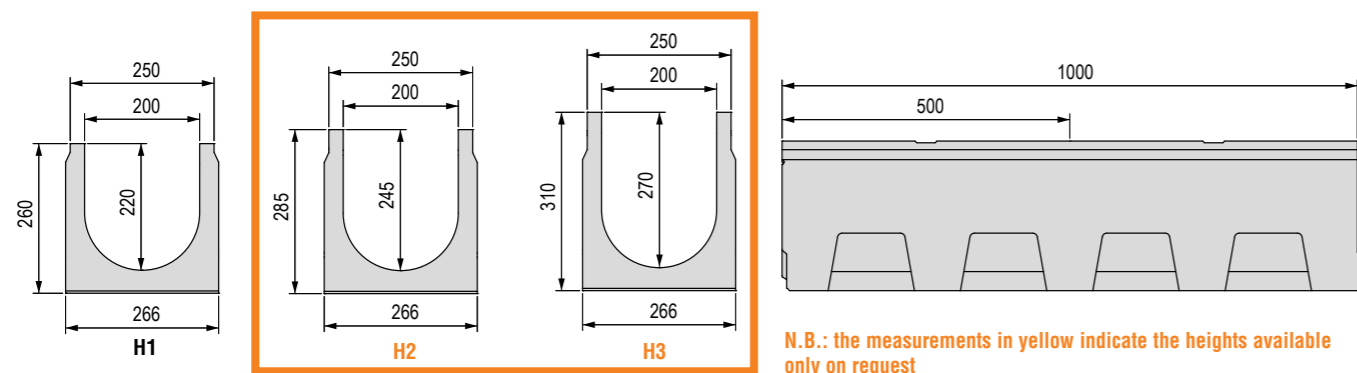

Available Thin covers

N.B.: available on request with 10 mm heelguard slot and in AISI 316 stainless steel

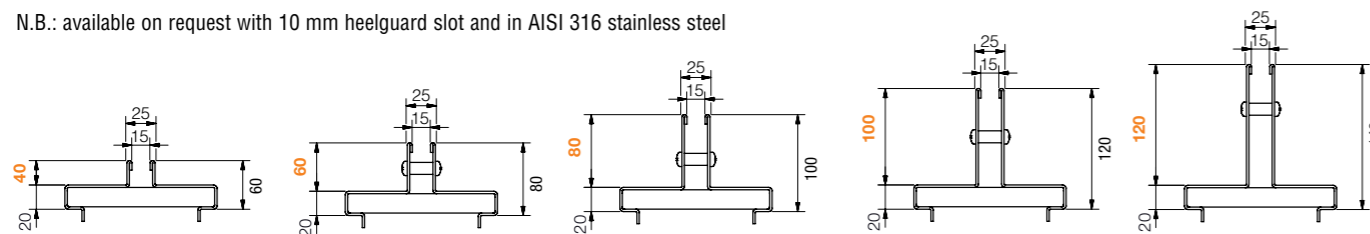

Vibro-Base 200 Series channel without grating - Length 1,000 / 500 mm

Channel L mm	Code	Description	Water passage mm	Run-off section cm ²	Weight kg	Pieces pallet
1,000	4F20S	Vibro-compressed concrete channel H1	200	397	60.50	loose
	4F21S	Vibro-compressed concrete channel H2	200	447	62.03	loose
	4F22S	Vibro-compressed concrete channel H3	200	497	63.55	loose
500	4F25S	Vibro-compressed concrete channel H1	200	397	30.25	loose
	4F26S	Vibro-compressed concrete channel H2	200	447	31.12	loose
	4F27S	Vibro-compressed concrete channel H3	200	497	31.78	loose

Vibro-Base 200 Series concrete sump unit without grating

Sump unit L mm	Code	Description	Weight kg
500	4F20PZ	Reinforced concrete sump unit L 500 mm	96.80

Thin covers with central slot - Slot width 15 mm

GALVANISED

Cover L mm	Code	Description	Slot height mm	Weight kg	Load class
1,000	4F20T0	Thin central cover, hot-dip galvanised, Th. 20/10	40	7.77	C 250
	4F20T	Thin central cover, hot-dip galvanised, Th. 20/10	60	8.40	
	4F20T1	Thin central cover, hot-dip galvanised, Th. 20/10	80	9.03	D 400
	4F20T2	Thin central cover, hot-dip galvanised, Th. 20/10	100	9.65	
	4F20T3	Thin central cover, hot-dip galvanised, Th. 20/10	120	10.28	
500	4F25T0	Thin central cover, hot-dip galvanised, Th. 20/10	40	3.89	C 250
	4F25T	Thin central cover, hot-dip galvanised, Th. 20/10	60	4.20	
	4F25T1	Thin central cover, hot-dip galvanised, Th. 20/10	80	4.51	D 400
	4F25T2	Thin central cover, hot-dip galvanised, Th. 20/10	100	4.83	
	4F25T3	Thin central cover, hot-dip galvanised, Th. 20/10	120	5.14	

N.B.: the Thin cover is supplied loose

AISI 304 STAINLESS STEEL

Cover L mm	Code	Description	Slot height mm	Weight kg	Load class
1,000	4F20I0	Thin central cover, AISI 304 stainless steel, Th. 20/10	40	7.77	C 250
	4F20I	Thin central cover, AISI 304 stainless steel, Th. 20/10	60	8.40	
	4F20I1	Thin central cover, AISI 304 stainless steel, Th. 20/10	80	9.03	D 400
	4F20I2	Thin central cover, AISI 304 stainless steel, Th. 20/10	100	9.66	
	4F20I3	Thin central cover, AISI 304 stainless steel, Th. 20/10	120	10.28	
500	4F25I0	Thin central cover, AISI 304 stainless steel, Th. 20/10	40	3.89	C 250
	4F25I	Thin central cover, AISI 304 stainless steel, Th. 20/10	60	4.20	
	4F25I1	Thin central cover, AISI 304 stainless steel, Th. 20/10	80	4.52	D 400
	4F25I2	Thin central cover, AISI 304 stainless steel, Th. 20/10	100	4.83	
	4F25I3	Thin central cover, AISI 304 stainless steel, Th. 20/10	120	5.14	

N.B.: the Thin cover is supplied loose

Inspection buckets for Thin covers with central slot - Slot width 15 mm

GALVANISED

Bucket L mm	Code	Description	Slot height mm	Weight kg	Load class
500	4F25V0	Inspection bucket for galvanised Thin central cover	40	5.83	C 250
	4F25V	Inspection bucket for galvanised Thin central cover	60	6.61	
	4F25V1	Inspection bucket for galvanised Thin central cover	80	7.39	D 400
	4F25V2	Inspection bucket for galvanised Thin central cover	100	8.17	
	4F25V3	Inspection bucket for galvanised Thin central cover	120	8.96	

N.B.: the Thin bucket is supplied loose

AISI 304 STAINLESS STEEL

Bucket L mm	Code	Description	Slot height mm	Weight kg	Load class
500	4F25VI0	Inspection bucket for Thin central cover made of AISI 304 stainless steel	40	5.83	C 250
	4F25VI	Inspection bucket for Thin central cover made of AISI 304 stainless steel	60	6.61	
	4F25VI1	Inspection bucket for Thin central cover made of AISI 304 stainless steel	80	7.39	D 400
	4F25VI2	Inspection bucket for Thin central cover made of AISI 304 stainless steel	100	8.17	
	4F25VI3	Inspection bucket for Thin central cover made of AISI 304 stainless steel	120	8.96	

N.B.: the Thin bucket is supplied loose

VIBRO-COMPRESSED CONCRETE CHANNELS VIBRO-BASE 200 SERIES WITH THIN COVER SIDE SLOT



Vibro-Base 200 Series channel dimensions

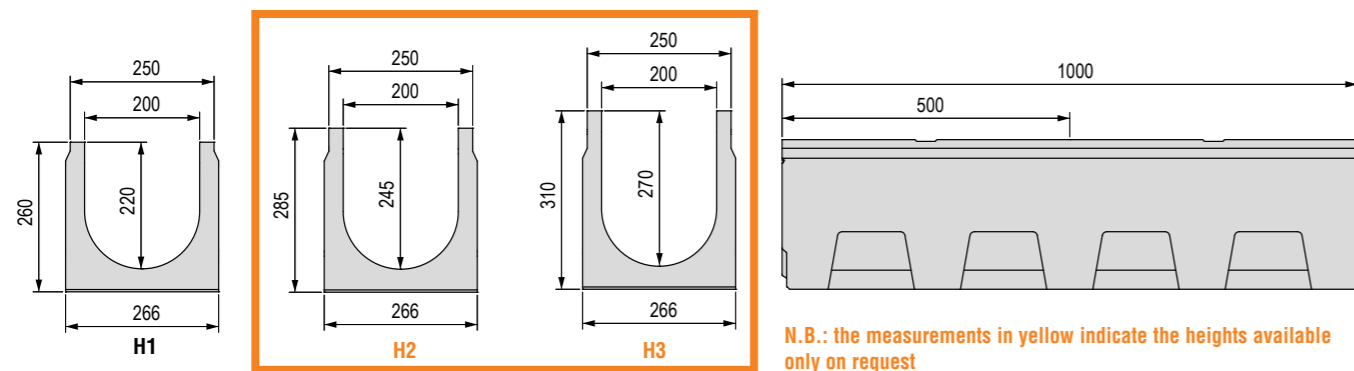

Available Thin covers

N.B.: available on request with 10 mm heelguard slot and in AISI 316 stainless steel

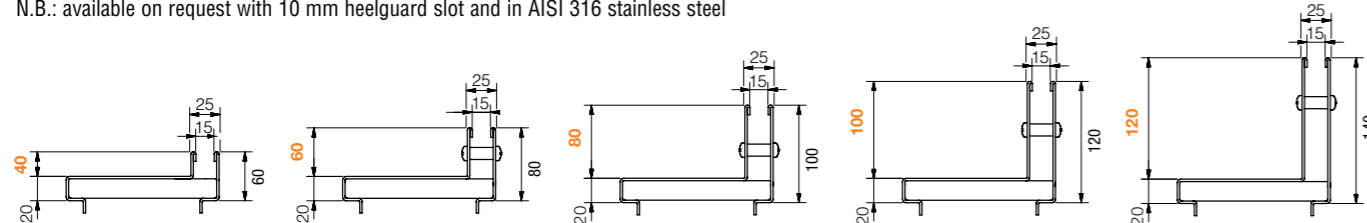

Vibro-Base 200 Series channel without grating - Length 1,000 / 500 mm

Channel L mm	Code	Description	Water passage mm	Run-off section cm ²	Weight kg	Pieces pallet
1,000	4F20S	Vibro-compressed concrete channel H1	200	397	60.50	loose
	4F21S	Vibro-compressed concrete channel H2	200	447	62.03	loose
	4F22S	Vibro-compressed concrete channel H3	200	497	63.55	loose
500	4F25S	Vibro-compressed concrete channel H1	200	397	30.25	loose
	4F26S	Vibro-compressed concrete channel H2	200	447	31.12	loose
	4F27S	Vibro-compressed concrete channel H3	200	497	31.78	loose

Vibro-Base 200 Series concrete sump unit without grating

Sump unit L mm	Code	Description	Weight kg
500	4F20PZ	Reinforced concrete sump unit L 500 mm	96.80



Thin covers with side slot - Slot width 15 mm

GALVANISED

Cover L mm	Code	Description	Slot height mm	Weight kg	Load class
1,000	4F20L0	Thin side cover, hot-dip galvanised, Th. 20/10	40	7.77	C 250
	4F20L	Thin side cover, hot-dip galvanised, Th. 20/10	60	8.40	
	4F20L1	Thin side cover, hot-dip galvanised, Th. 20/10	80	9.03	D 400
	4F20L2	Thin side cover, hot-dip galvanised, Th. 20/10	100	9.65	
	4F20L3	Thin side cover, hot-dip galvanised, Th. 20/10	120	10.28	
500	4F25L0	Thin side cover, hot-dip galvanised, Th. 20/10	40	3.89	C 250
	4F25L	Thin side cover, hot-dip galvanised, Th. 20/10	60	4.20	
	4F25L1	Thin side cover, hot-dip galvanised, Th. 20/10	80	4.51	D 400
	4F25L2	Thin side cover, hot-dip galvanised, Th. 20/10	100	4.83	
	4F25L3	Thin side cover, hot-dip galvanised, Th. 20/10	120	5.14	

N.B.: the Thin cover is supplied loose

AISI 304 STAINLESS STEEL

Cover L mm	Code	Description	Slot height mm	Weight kg	Load class
1,000	4F20IL0	Thin side cover, AISI 304 stainless steel, Th. 20/10	40	7.77	C 250
	4F20IL	Thin side cover, AISI 304 stainless steel, Th. 20/10	60	8.40	
	4F20IL1	Thin side cover, AISI 304 stainless steel, Th. 20/10	80	9.03	D 400
	4F20IL2	Thin side cover, AISI 304 stainless steel, Th. 20/10	100	9.66	
	4F20IL3	Thin side cover, AISI 304 stainless steel, Th. 20/10	120	10.28	
500	4F25IL0	Thin side cover, AISI 304 stainless steel, Th. 20/10	40	3.89	C 250
	4F25IL	Thin side cover, AISI 304 stainless steel, Th. 20/10	60	4.20	
	4F25IL1	Thin side cover, AISI 304 stainless steel, Th. 20/10	80	4.52	D 400
	4F25IL2	Thin side cover, AISI 304 stainless steel, Th. 20/10	100	4.83	
	4F25IL3	Thin side cover, AISI 304 stainless steel, Th. 20/10	120	5.14	

N.B.: the Thin cover is supplied loose



Inspection buckets for Thin covers with side slot - Slot width 15 mm

GALVANISED

Bucket L mm	Code	Description	Slot height mm	Weight kg	Load class
500	4F25VL0	Inspection bucket for galvanised Thin side cover	40	5.83	C 250
	4F25VL	Inspection bucket for galvanised Thin side cover	60	6.61	
	4F25VL1	Inspection bucket for galvanised Thin side cover	80	7.39	D 400
	4F25VL2	Inspection bucket for galvanised Thin side cover	100	8.17	
	4F25VL3	Inspection bucket for galvanised Thin side cover	120	8.96	

N.B.: the Thin bucket is supplied loose

AISI 304 STAINLESS STEEL

Bucket L mm	Code	Description	Slot height mm	Weight kg	Load class
500	4F25VL10	Inspection bucket for Thin side cover made of AISI 304 stainless steel	40	5.83	C 250
	4F25VLI	Inspection bucket for Thin side cover made of AISI 304 stainless steel	60	6.61	
	4F25VLI1	Inspection bucket for Thin side cover made of AISI 304 stainless steel	80	7.39	D 400
	4F25VLI2	Inspection bucket for Thin side cover made of AISI 304 stainless steel	100	8.17	
	4F25VLI3	Inspection bucket for Thin side cover made of AISI 304 stainless steel	120	8.96	

N.B.: the Thin bucket is supplied loose

VIBRO-COMPRESSED CONCRETE CHANNELS

SERIES

The new generation of GRIDIRON R SERIES vibro-compressed channels is the result of a careful and precise design, thereby introducing innovation and perfection to the channel sector.

Vibro-compressed concrete is obtained from a mixture of certified riverbed inert materials and Grade 425 concrete, combined with vibration and compression processing methods that make R SERIES channels highly resistant to compression ($R_{cK} > 45 \text{ N/mm}^2$), frost and thaw cycles, climate-induced erosion and mechanical stress. The GJS500-7 ductile iron gratings, resting on galvanised steel edge rails, are secured with a special mechanical fastening system creating a unified structure, which helps to uniformly distribute the stress created by the passage of vehicles, while guaranteeing stability and silence.

The classification and control procedures comply with the European UNI EN 1433 standard.

- R 122
- R 150
- R 210
- R 265
- R 315
- R 365
- R 495
- R 595



LOAD CLASSES

In accordance with the UNI EN 1433 standard

A 15 • B 125 • C 250 • D 400 • E 600 • F 900



VIBRO-COMPRESSED CONCRETE CHANNELS R SERIES

SYSTEM AND TECHNICAL CHARACTERISTICS



FASTENING SYSTEM DESIGNED BY GRIDIRON

Tang embedded into the concrete with a housing for the nut through which the screw is inserted



ANCHORING OF THE GALVANISED EDGE RAILS

The galvanised steel edge rails are anchored to the channel with lateral fastenings and with special anchors designed by GRIDIRON, which house the threaded nut through which the screw is inserted. Given that the edge rail is not directly threaded, this important device allows for easily replacing the nut should its threading become worn.

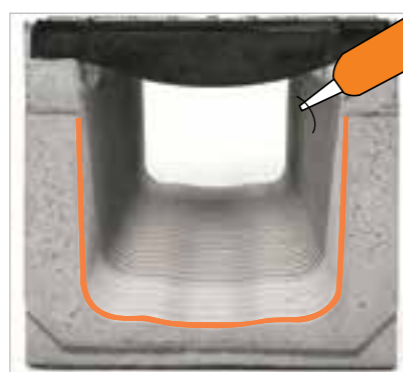
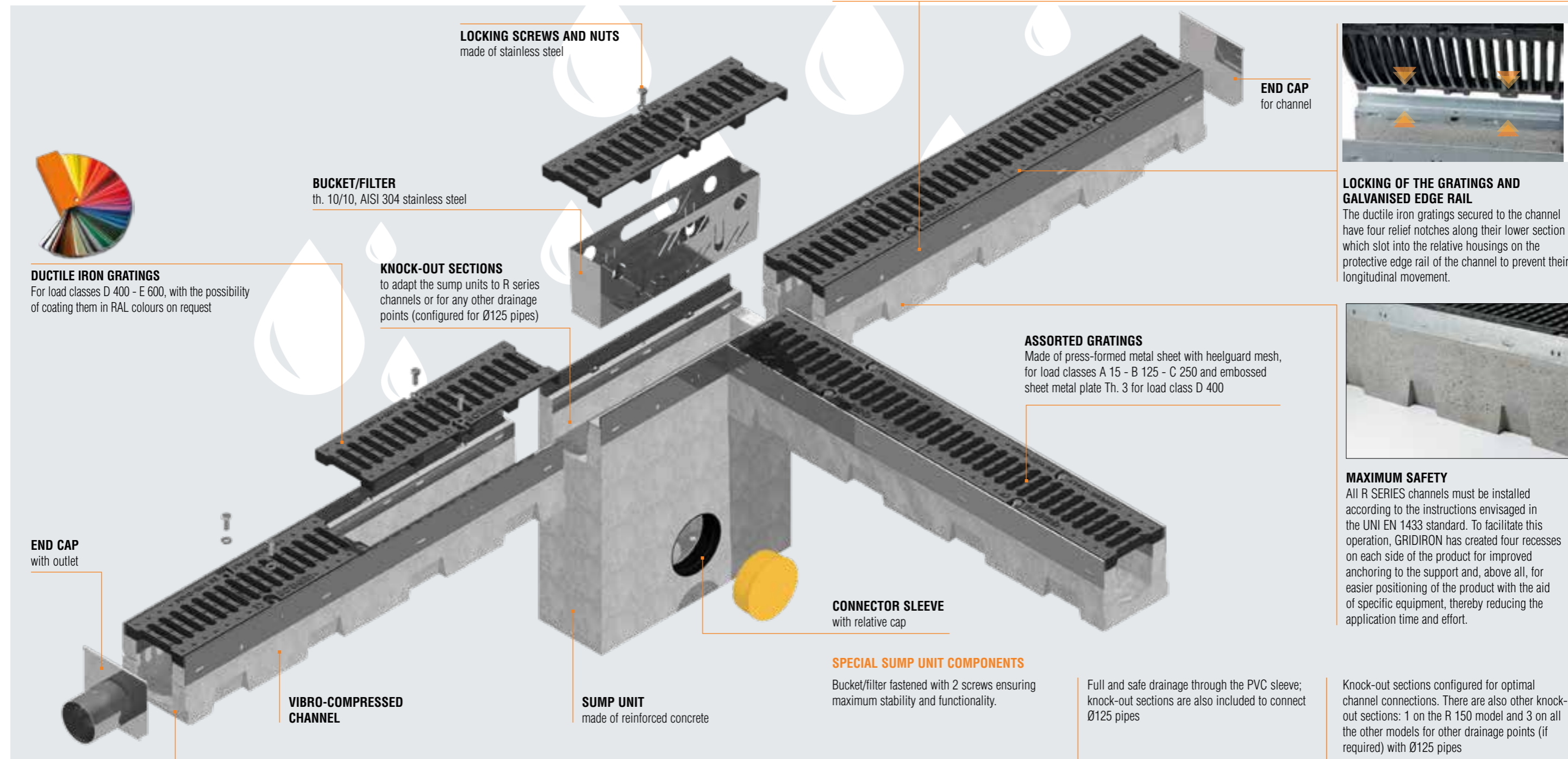

PERFECT AND STABLE JOINING
The channel end caps are made with male-female connections, with an inner slot that allows for sealing them together. It is advisable to use silicone sealant with neutral cross-linkage and low modulus. To guarantee perfect joining, the bottom sections of the ends are bevelled to prevent laying material from building up when the two parts slide along the underlying bed and are joined together.

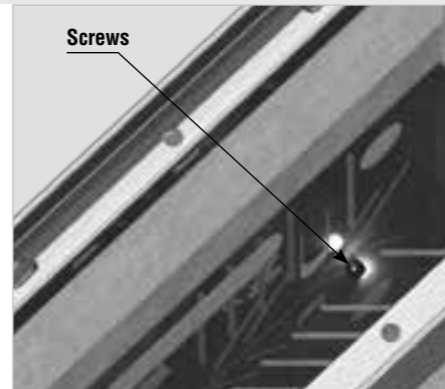

Drainage hole: The only function of the hole on the bottom is to avoid the sump unit filling with water during warehouse storage.

PVC sleeve fitted with elastomer seal

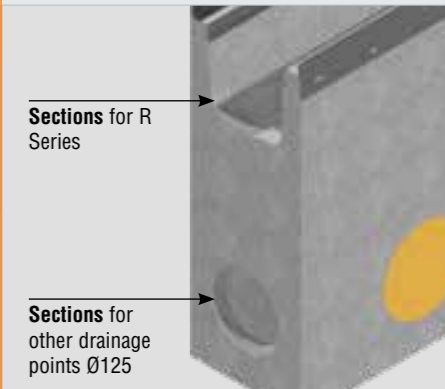

VIBRO-COMPRESSED CONCRETE CHANNELS **R SERIES**

RAISING FRAME FOR TWO-STAGE LAYING

The steel raising frame is an indispensable element for situations in which the drainage line must be laid but the state of progress of the work entails a certain delay before the installation of the final paving. The raising frame, and hence the paving, can be installed even long after the channel is laid; in this way, the site can be kept dry and safe for the time required to complete the work.

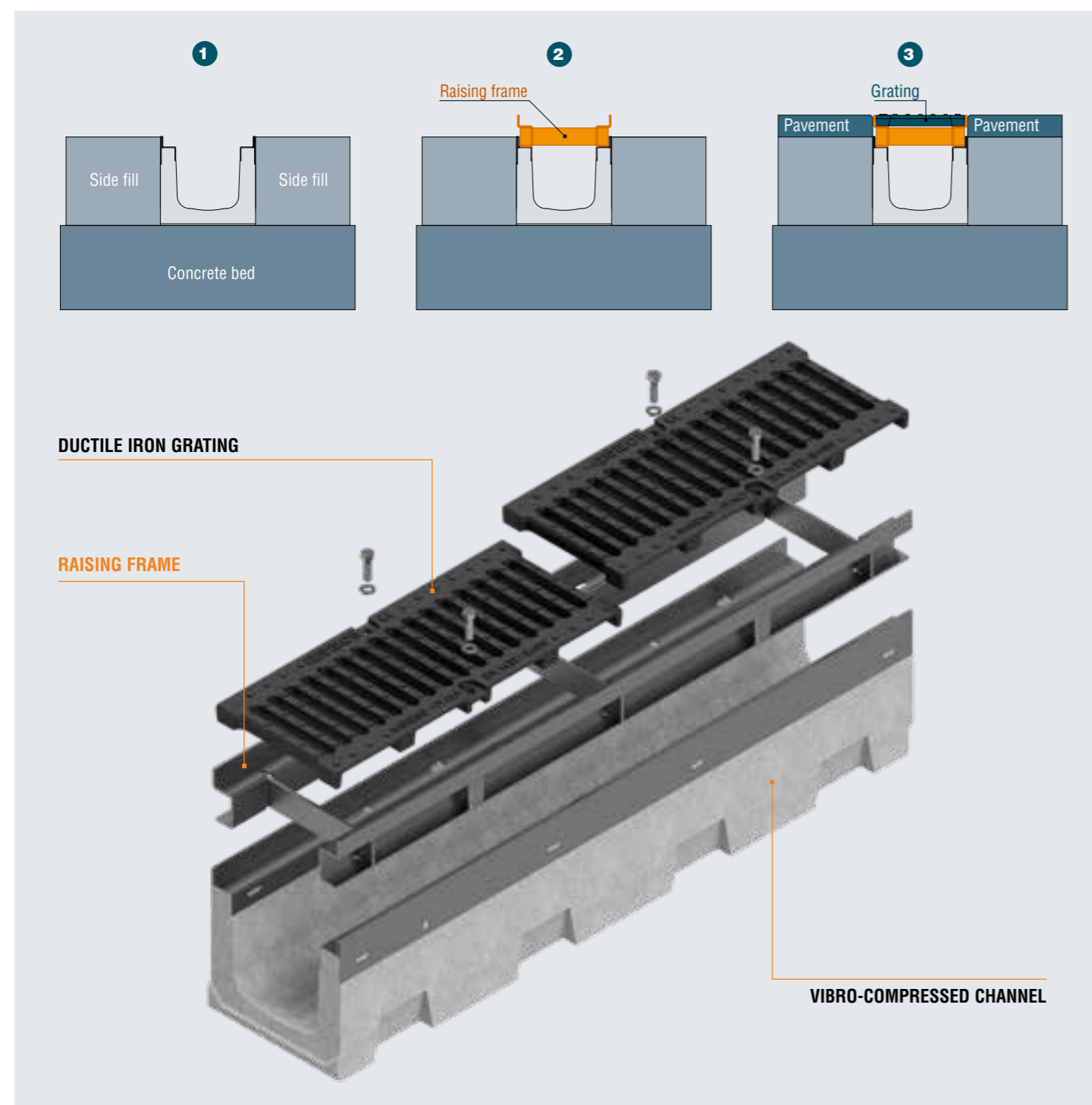

VIBRO-COMPRESSED CONCRETE CHANNELS **R 122 SERIES**

Grating width 122 mm

Vibro-compressed concrete channel with galvanised protective edge rails. The channels are sold exclusively in complete pallets and together with the gratings.

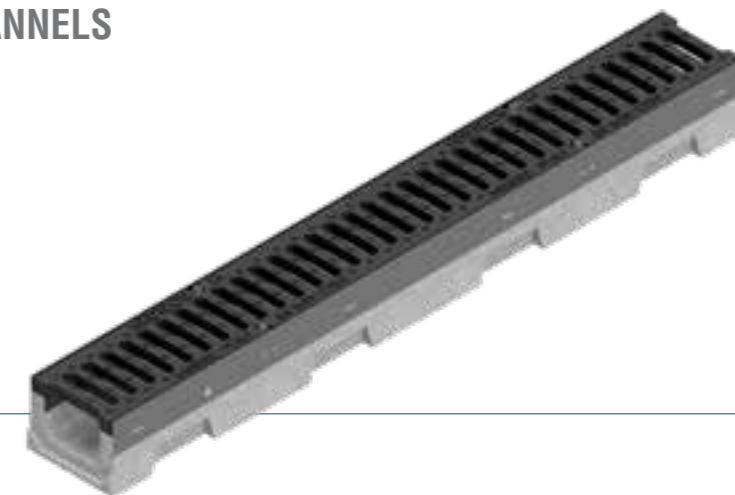

R 122 Series channel dimensions

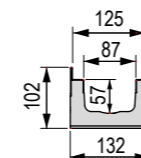

Available gratings N.B.: the gratings in yellow are available only on request

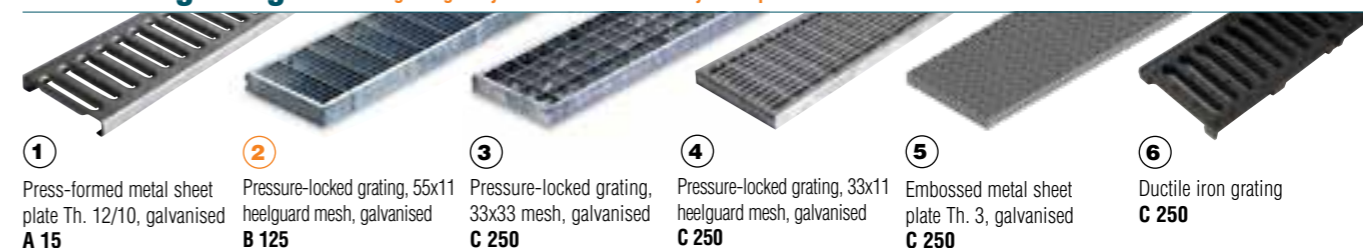

- ① Press-formed metal sheet plate Th. 12/10, galvanised **A 15**
- ② Pressure-locked grating, 55x11 heelguard mesh, galvanised **B 125**
- ③ Pressure-locked grating, 33x33 mesh, galvanised **C 250**
- ④ Pressure-locked grating, 33x11 heelguard mesh, galvanised **C 250**
- ⑤ Embossed metal sheet plate Th. 3, galvanised **C 250**
- ⑥ Ductile iron grating **C 250**

R 122 Series channel complete with grating - Length 1,000

Channel L mm	Code	Grating	Description of the channel assembled with the grating complete with accessories	Weight kg	Load class
1,000	4R00SGL	①	Channel complete with press-formed metal sheet grating with C-shaped edges, Th. 12/10, hot-dip galvanised	17.61	A 15
	4R00SGPB	②	Channel complete with pressure-locked grating with C-shaped edges, 20x2-10x2 55x11 heelguard mesh, hot-dip galvanised	18.20	B 125
	4R00SGP	③	Channel complete with pressure-locked grating with C-shaped edges, 20x2-10x2 33x33, hot-dip galvanised	18.38	C 250
	4R00SGPA	④	Channel complete with pressure-locked grating with C-shaped edges, 20x2-10x2 33x11 heelguard mesh, hot-dip galvanised	23.81	
	4R00SP	⑤	Channel complete with embossed metal sheet plate Th. 3, reinforced and hot-dip galvanised	21.79	
	4R00SGG	⑥	Channel complete with 2 x GJS500-7 ductile iron gratings	23.00	

R 122 Series accessories

Code	Description	Weight kg
4R00TID	Right-hand end cap for channel closure female side	1.16
4R00TIS	Left-hand end cap for channel closure male side	0.30
4R00RI	End cap with outlet for channel Ø40 mm	0.30
	Channel bottom drilling Ø82 mm	

R 122 Series channel without grating - Length 1,000

Channel L mm	Code	Description	Water passage mm	Run-off section cm ²	Weight kg	Pieces pallet
1,000	4R00S	Additivated vibro-compressed concrete R122 channel with galvanised protective edge rails, complying with the UNI EN 1433 standard.	87	45	15.81	56

VIBRO-COMPRESSED CONCRETE CHANNELS

R 150 SERIES

Grating width 150 mm

Vibro-compressed concrete channel with galvanised protective edge rails.
The channels are sold exclusively in complete pallets and together with the gratings.

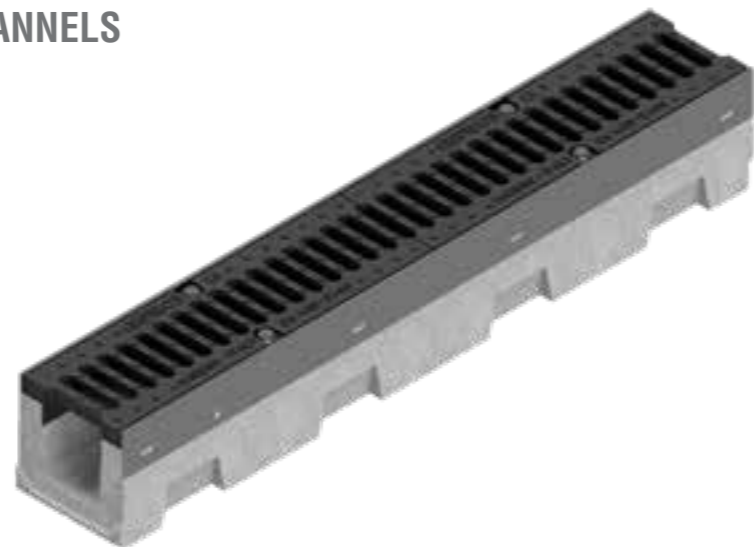

R 150 Series channel dimensions

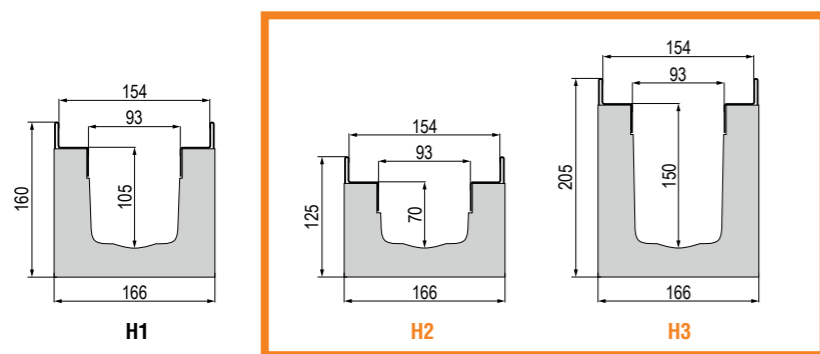

N.B.: the measurements in yellow indicate the heights available only on request

Available gratings

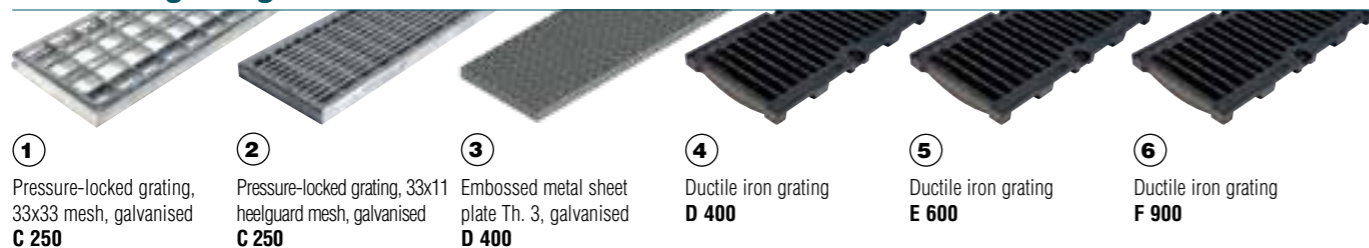

R 150 Series channel complete with grating - Length 1,000

Channel L mm	Code	Grating	Description of the channel assembled with the grating complete with accessories	Weight kg	Load class
1,000	4R01SGP	①	Channel complete with pressure-locked grating with C-shaped edges, 25x2-10x2 33x33, hot-dip galvanised	38.08	C 250
	4R01SGPA	②	Channel complete with pressure-locked grating with C-shaped edges, 25x2-10x2 33x11 heelguard mesh, hot-dip galvanised	38.68	
	4R01SP	③	Channel complete with embossed metal sheet plate Th. 3, reinforced and hot-dip galvanised	45.26	D 400
	4R01SGG	④	Channel complete with 2 x GJS500-7 D 400 ductile iron gratings	43.00	
	4R01SGSE	⑤	Channel complete with 2 x GJS500-7 E 600 ductile iron gratings	43.20	
	4R01SGSF	⑥	Channel complete with 2 x GJS500-7 F 900 ductile iron gratings	44,94	

R 150 Series accessories

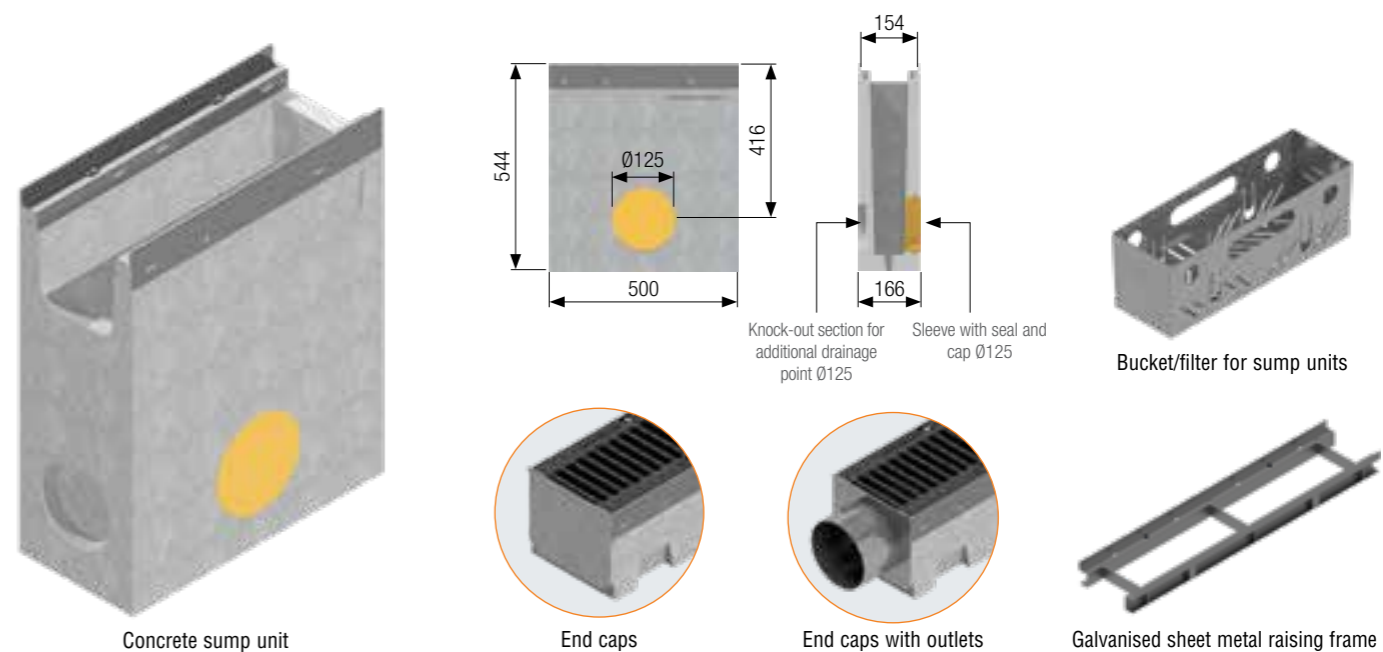

R 150 Series concrete sump unit complete with grating - Length 500 mm

Sump unit L mm	Code	Grating	Description of the sump unit assembled with the grating complete with accessories	Weight kg	Load class
500	4R01PZGP	①	Sump unit complete with pressure-locked grating with C-shaped edges, 25x2-10x2 33x33, hot-dip galvanised	66.11	C 250
	4R01PZGPA	②	Sump unit complete with pressure-locked grating with C-shaped edges, 25x2-10x2 33x11 heelguard mesh, hot-dip galvanised	66.87	
	4R01PZP	③	Sump unit complete with embossed metal sheet plate Th. 3, reinforced and hot-dip galvanised	69.65	D 400
	4R01PZGS	④	Sump unit complete with GJS500-7 D400 ductile iron grating	68.48	
	4R01PZGSE	⑤	Sump unit complete with GJS500-7 E600 ductile iron grating	68.60	
	4R01PZGSF	⑥	Sump unit complete with GJS500-7 F 900 ductile iron grating	69,49	

R 150 Series concrete sump unit without grating and accessories

Code	Description	Weight kg
4R01PZ	Reinforced concrete sump unit with galvanised edge rail L 500 mm	64.20
4R01VI	Bucket/Filter, AISI 304 stainless steel	1.16
4R01TID	Right-hand end cap for channel closure female side	0.30
4R01TIS	Left-hand end cap for channel closure male side	0.30
4R01RI	End cap with outlet drainage pipe diam. 89 mm	0.52
4R01PR	Galvanised sheet metal raising frame for two-stage channel laying	
	Channel bottom drilling Ø75 mm	

R 150 Series channel without grating - Length 1,000

Channel L mm	Code	Description	Water passage mm	Run-off section cm ²	Weight kg	Pieces pallet
1,000	4R01S	Additivated vibro-compressed concrete R150 H1 channel with galvanised protective edge rails, complying with the UNI EN 1433 standard.	93	90	34.36	36
	4R011S	Additivated vibro-compressed concrete R150 H2 channel with galvanised protective edge rails, complying with the UNI EN 1433 standard.	93	60	27,50	42
	4R012S	Additivated vibro-compressed concrete R150 H3 channel with galvanised protective edge rails, complying with the UNI EN 1433 standard.	93	133	42,00	30

VIBRO-COMPRESSED CONCRETE CHANNELS R 210 SERIES

Grating width 210 mm

Vibro-compressed concrete channel with galvanised protective edge rails.
The channels are sold exclusively in complete pallets and together with the gratings.

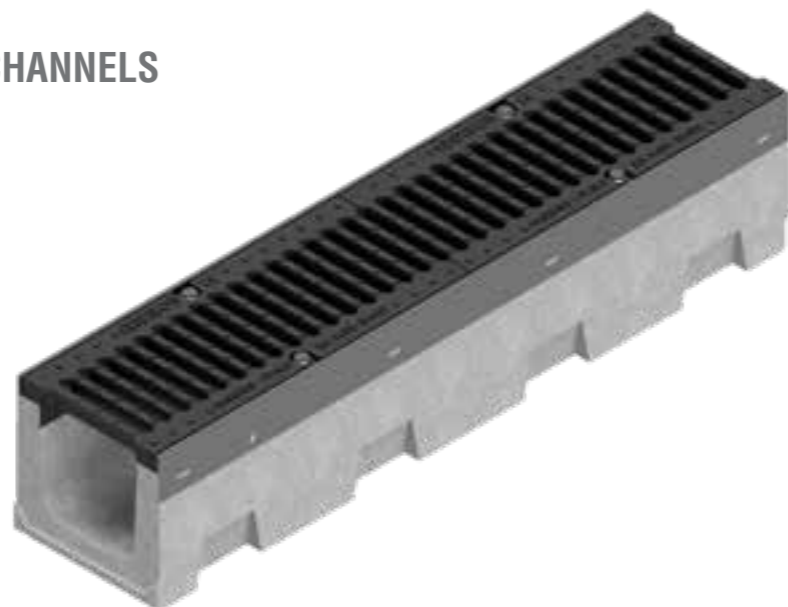

R 210 Series channel dimensions

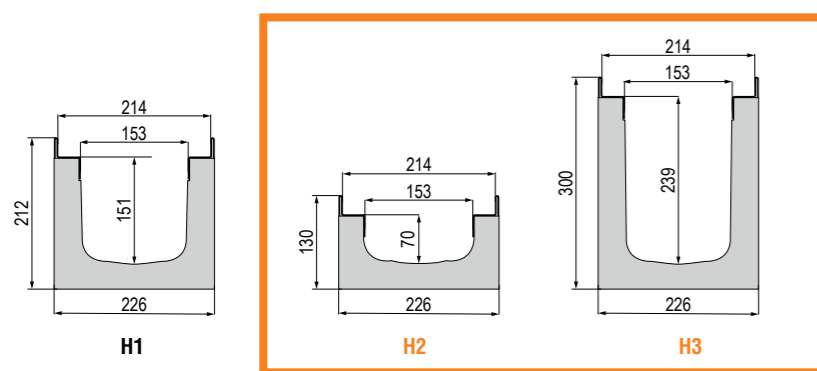

N.B.: the measurements in yellow indicate the heights available only on request

Available gratings

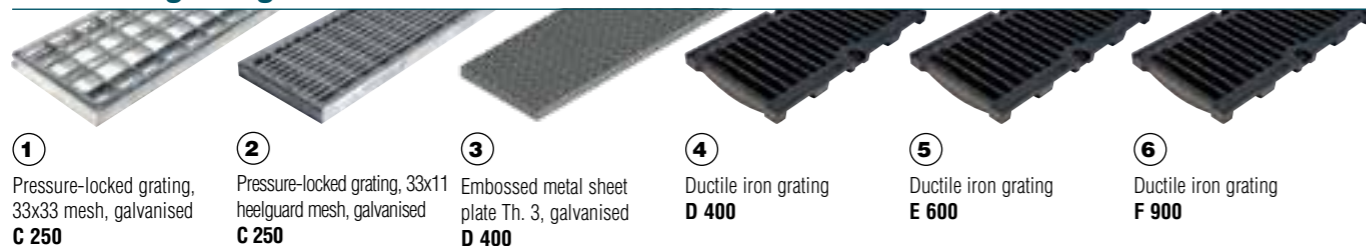

- ① Pressure-locked grating, 33x33 mesh, galvanised **C 250**
- ② Pressure-locked grating, 33x11 heelguard mesh, galvanised **C 250**
- ③ Embossed metal sheet plate Th. 3, galvanised **D 400**
- ④ Ductile iron grating **D 400**
- ⑤ Ductile iron grating **E 600**
- ⑥ Ductile iron grating **F 900**

R 210 Series channel complete with grating - Length 1,000

Channel L mm	Code	Grating	Description of the H1 channel assembled with the grating complete with accessories	Weight kg	Load class
1,000	4R02SGP	①	Channel complete with pressure-locked grating with C-shaped edges, 25x2-10x2 33x33, hot-dip galvanised	54.65	C 250
	4R02SGPA	②	Channel complete with pressure-locked heelguard grating with C-shaped edges, 25x2-10x2 33x11, hot-dip galvanised	55.38	
	4R02SP	③	Channel complete with embossed metal sheet plate Th. 3, reinforced and hot-dip galvanised	64.28	D 400
	4R02SGG	④	Channel complete with 2 x GJS500-7 D 400 ductile iron gratings	64.00	
	4R02SGSE	⑤	Channel complete with 2 x GJS500-7 E 600 ductile iron gratings	66.20	
	4R02SGSF	⑥	Channel complete with 2 x GJS500-7 F 900 ductile iron gratings	69.59	

R 210 Series accessories

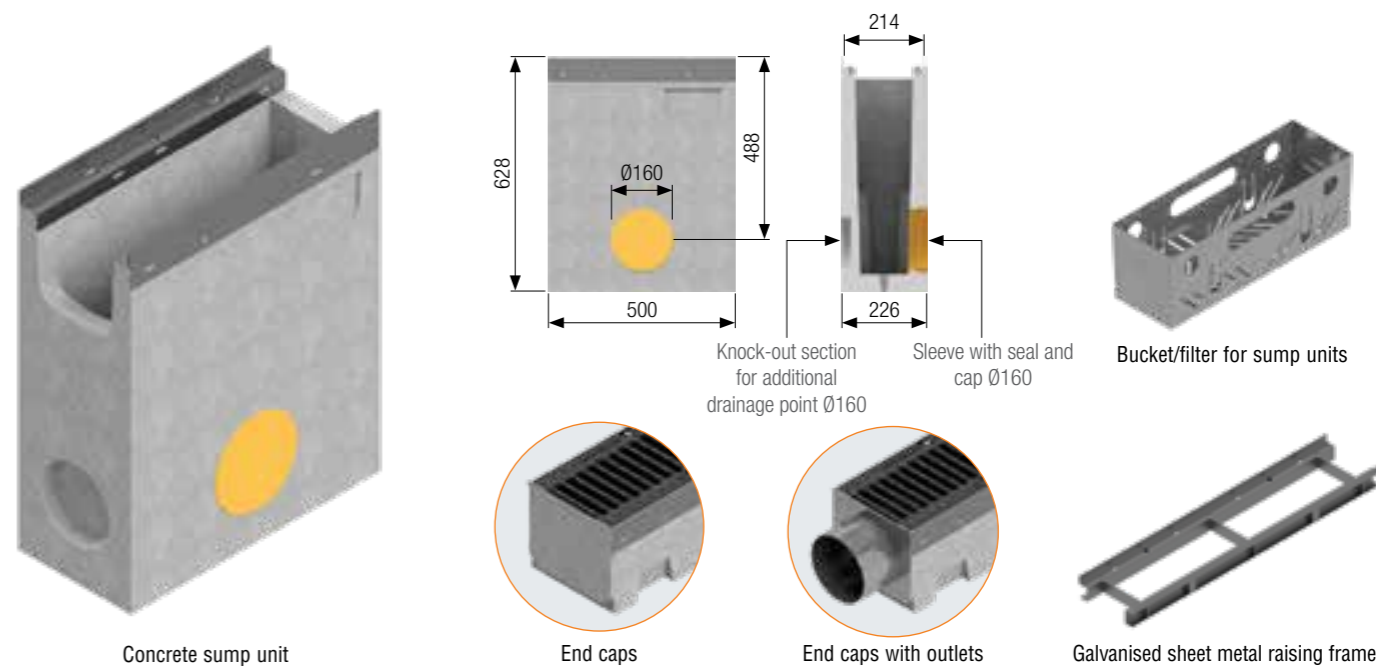

R 210 Series concrete sump unit complete with grating - Length 500 mm

Sump unit L mm	Code	Grating	Description of the sump unit assembled with the grating complete with accessories	Weight kg	Load class
500	4R02PZGP	①	Sump unit complete with pressure-locked grating with C-shaped edges, 25x2-10x2 33x33, hot-dip galvanised	80.65	C 250
	4R02PZGPA	②	Sump unit complete with pressure-locked grating with C-shaped edges, 25x2-10x2 33x11 heelguard mesh, hot-dip galvanised	81.15	
	4R02PZP	③	Sump unit complete with embossed metal sheet plate Th. 3, reinforced and hot-dip galvanised	86.00	D 400
	4R02PZGS	④	Sump unit complete with GJS500-7 D 400 ductile iron grating	85.06	
	4R02PZGSE	⑤	Sump unit complete with GJS500-7 E 600 ductile iron grating	86.20	
	4R02PZGSF	⑥	Sump unit complete with GJS500-7 F 900 ductile iron grating	88.62	

R 210 Series concrete sump unit without grating and accessories

Code	Description	Weight kg
4R02PZ	Reinforced concrete sump unit with galvanised edge rail L 500 mm	78.80
4R02VI	Bucket/Filter, AISI 304 stainless steel	1.50
4R02TID	Right-hand end cap for channel closure female side	0.53
4R02TIS	Left-hand end cap for channel closure male side	0.53
4R02RI	End cap with outlet Ø156 mm	1.30
4R02PR	Galvanised sheet metal raising frame for two-stage channel laying	
	Channel bottom drilling Ø125 mm	

R 210 Series channel without grating - Length 1,000

Channel L mm	Code	Description	Water passage mm	Run-off section cm ²	Weight kg	Pieces pallet
1,000	4R02S	Additivated vibro-compressed concrete R210 H1 channel with galvanised protective edge rails, complying with the UNI EN 1433 standard.	153	215	49.88	20
	4R021S	Additivated vibro-compressed concrete R210 H2 channel with galvanised protective edge rails, complying with the UNI EN 1433 standard.	153	115	35.22	25
	4R022S	Additivated vibro-compressed concrete R210 H3 channel with galvanised protective edge rails, complying with the UNI EN 1433 standard.	153	342	60.34	20

VIBRO-COMPRESSED CONCRETE CHANNELS R 265 SERIES

Grating width 265 mm

Vibro-compressed concrete channel with galvanised protective edge rails.
The channels are sold exclusively in complete pallets and together with the gratings.



R 265 Series channel dimensions

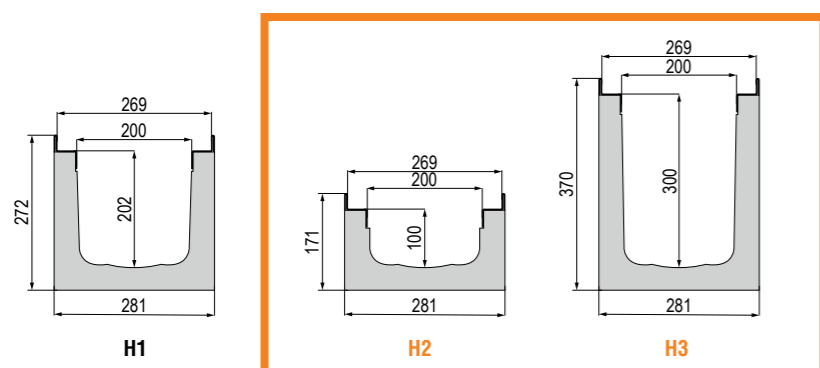

N.B.: the measurements in yellow indicate the heights available only on request

Available gratings

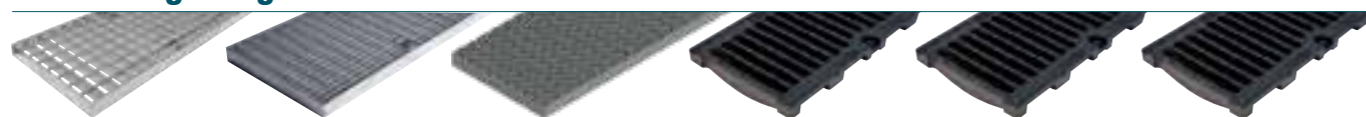

- ① Pressure-locked grating, 33x33 mesh, galvanised **C 250**
- ② Pressure-locked grating, 33x15 heelguard mesh, galvanised **C 250**
- ③ Embossed metal sheet plate Th. 3, galvanised **D 400**
- ④ Ductile iron grating **D 400**
- ⑤ Ductile iron grating **E 600**
- ⑥ Ductile iron grating **F 900**

R 265 Series channel complete with grating - Length 1,000

Channel L mm	Code	Grating	Description of the channel assembled with the grating complete with accessories	Weight kg	Load class
1,000	4R03SGP	①	Channel complete with pressure-locked grating 30x3-10x2 33x33, hot-dip galvanised	80,56	C 250
	4R03SGPA	②	Channel complete with pressure-locked grating 30x3-10x2 33x15 heelguard mesh, hot-dip galvanised	83,12	
	4R03SP	③	Channel complete with embossed metal sheet plate Th. 3, reinforced and hot-dip galvanised	91,82	D 400
	4R03SGG	④	Channel complete with 2 x GJS500-7 D 400 ductile iron gratings	88,70	
	4R03SGSE	⑤	Channel complete with 2 x GJS500-7 E 600 ductile iron gratings	96,80	E 600
	4R03SGSF	⑥	Channel complete with 2 x GJS500-7 F 900 ductile iron gratings	98,58	

R 265 Series accessories

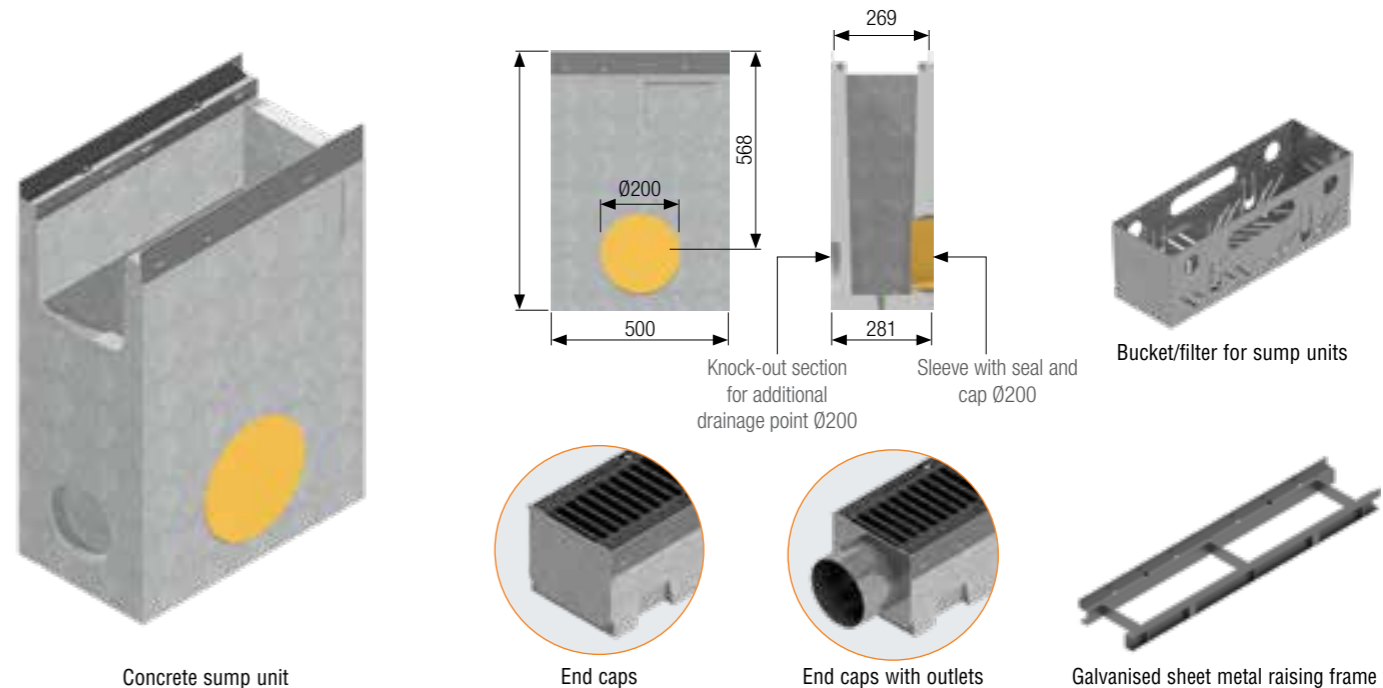

R 265 Series concrete sump unit complete with grating - Length 500 mm

Sump unit L mm	Code	Grating	Description of the sump unit assembled with the grating complete with accessories	Weight kg	Load class
500	4R03PZGP	①	Sump unit complete with pressure-locked grating 30x3-10x2 33x33, hot-dip galvanised	110.15	C 250
	4R03PZGPA	②	Sump unit complete with pressure-locked grating 30x3-10x2 33x15 heelguard mesh, hot-dip galvanised	111.81	
	4R03PZP	③	Sump unit complete with embossed metal sheet plate Th. 3, reinforced and hot-dip galvanised	115.42	D 400
	4R03PZGS	④	Sump unit complete with GJS500-7 D400 ductile iron grating	114.70	
	4R03PZGSE	⑤	Sump unit complete with GJS500-7 E600 ductile iron grating	117.86	E 600
	4R03PZGSF	⑥	Sump unit complete with GJS500-7 F 900 ductile iron grating	118,80	

R 265 Series concrete sump unit without grating and accessories

Code	Description	Weight kg
4R03PZ	Reinforced concrete sump unit with galvanised edge rail L 500 mm	105.80
4R03VI	Bucket/Filter, AISI 304 stainless steel	1.71
4R03TID	Right-hand end cap for channel closure female side	1.11
4R03TIS	Left-hand end cap for channel closure male side	1.11
4R03RI	End cap with outlet Ø156 mm	1.81
4R03PR	Galvanised sheet metal raising frame for two-stage channel laying	
	Channel bottom drilling Ø160 mm	

R 265 Series channel without grating - Length 1,000

Channel L mm	Code	Description	Water passage mm	Run-off section cm ²	Weight kg	Pieces pallet
1,000	4R03S	Additivated vibro-compressed concrete R265 H1 channel with galvanised protective edge rails, complying with the UNI EN 1433 standard.	200	376	72.58	16
	4R031S	Additivated vibro-compressed concrete R265 H2 channel with galvanised protective edge rails, complying with the UNI EN 1433 standard.	200	183	51,90	24
	4R032S	Additivated vibro-compressed concrete R265 H3 channel with galvanised protective edge rails, complying with the UNI EN 1433 standard.	200	577	92,00	12

VIBRO-COMPRESSED CONCRETE CHANNELS R 315 SERIES

Grating width 315 mm

Vibro-compressed concrete channel with galvanised protective edge rails.
The channels are sold exclusively in complete pallets and together with the gratings.

R 315 Series channel dimensions

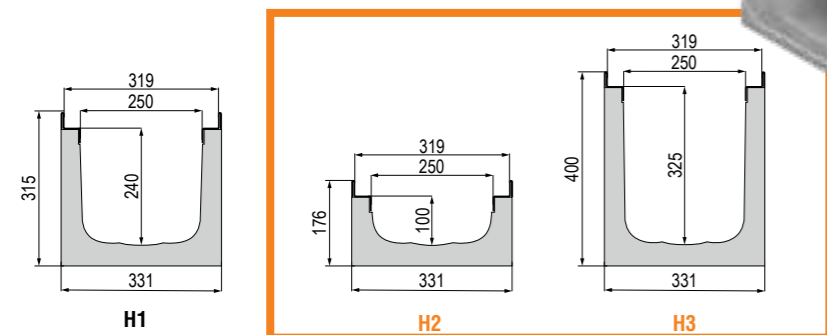

Available gratings

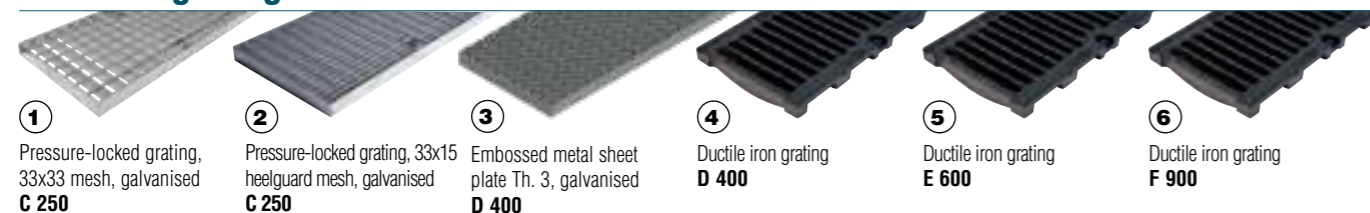

R 315 Series channel complete with grating - Length 1,000

Channel L mm	Code	Grating	Description of the channel assembled with the grating complete with accessories	Weight kg	Load class
1,000	4R04SGP	①	Channel complete with pressure-locked grating 30x4-10x3 33x33, hot-dip galvanised	104.65	C 250
	4R04SGPA	②	Channel complete with pressure-locked grating 30x4-10x3 33x15 heelguard mesh, hot-dip galvanised	106.62	
	4R04SP	③	Channel complete with embossed metal sheet plate Th. 3, reinforced and hot-dip galvanised	108.44	D 400
	4R04SGG	④	Channel complete with 2 x GJS500-7 D 400 ductile iron gratings	119.00	
	4R04SGE	⑤	Channel complete with 2 x GJS500-7 E 600 ductile iron gratings	124,70	
	4R04SGF	⑥	Channel complete with 2 x GJS500-7 F 900 ductile iron gratings	131,40	

R 315 Series accessories

Code	Description	Weight kg
4R04TID	Right-hand end cap for channel closure female side	1.52
4R04TIS	Left-hand end cap for channel closure male side	1.52
4R04RI	End cap with outlet Ø200 mm	1.90
4R04PR	Galvanised sheet metal raising frame for two-stage channel laying Channel bottom drilling Ø200 mm	

R 315 Series channel without grating - Length 1,000

Channel L mm	Code	Description	Water passage mm	Run-off section cm ²	Weight kg	Pieces pallet
1,000	4R04S	Additivated vibro-compressed concrete R315 H1 channel with galvanised protective edge rails, complying with the UNI EN 1433 standard.	250	562	79.3	9
	4R041S	Additivated vibro-compressed concrete R315 H2 channel with galvanised protective edge rails, complying with the UNI EN 1433 standard.	250	224	64,40	15
	4R042S	Additivated vibro-compressed concrete R315 H3 channel with galvanised protective edge rails, complying with the UNI EN 1433 standard.	250	778	107,75	4

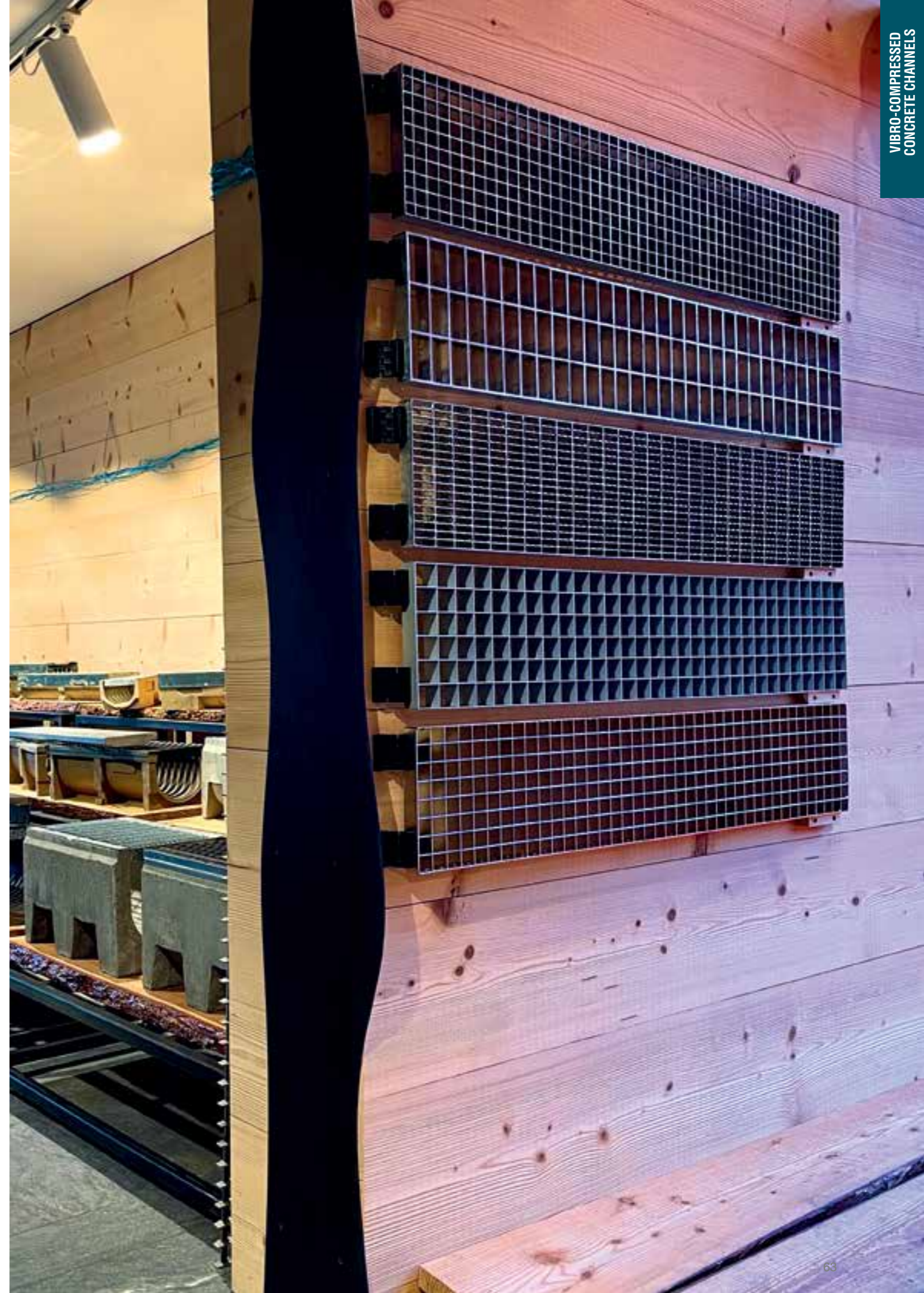

VIBRO-COMPRESSED CONCRETE CHANNELS

R 365 SERIES

Grating width 365 mm

Vibro-compressed concrete channel with galvanised protective edge rails.
The channels are sold exclusively in complete pallets and together with the gratings.

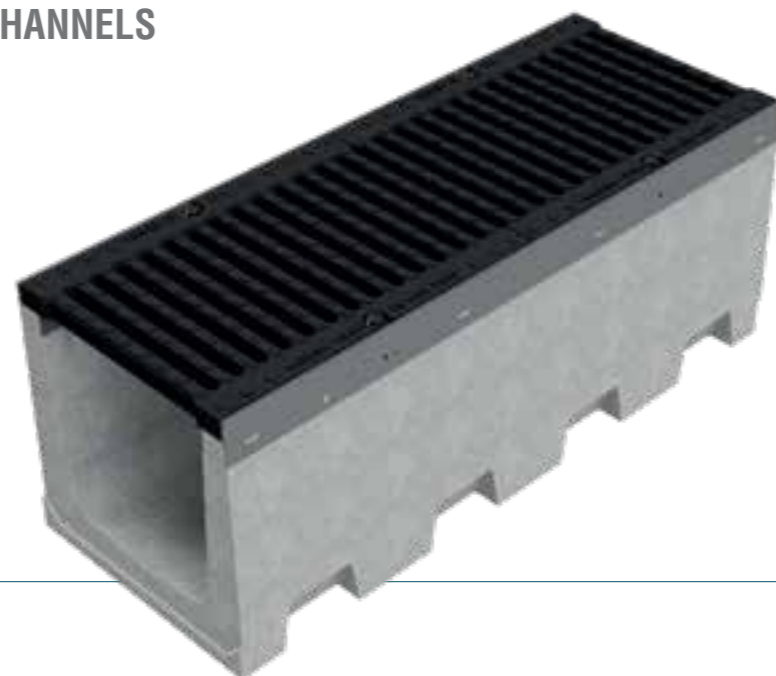

R 365 Series channel dimensions

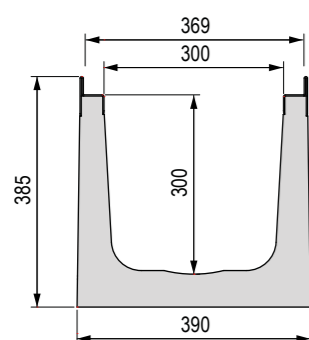

Available gratings *N.B.: the gratings in yellow are available only on request*



R 365 Series channel complete with grating - Length 1,000

Channel L mm	Code	Grating	Description of the channel assembled with the grating complete with accessories	Weight kg	Load class
1,000	4R04SGP	①	Channel complete with pressure-locked grating 30x4-10x3 33x33, hot-dip galvanised	142,00	C 250
	4R04SGPA	②	Channel complete with pressure-locked grating 30x4-10x3 33x15 heelguard mesh, hot-dip galvanised	148,00	
	4R05SGPC	③	Channel complete with pressure-locked grating 30x5-10x4 22x66 hot-dip galvanised	149,00	D 400
	4R05SGPA	④	Channel complete with pressure-locked grating 30x4-10x3 15x66 heelguard mesh, hot-dip galvanised	152,00	
	4R05SP	⑤	Channel complete with embossed metal sheet plate Th. 3, reinforced and hot-dip galvanised	161,00	
	4R05SGG	⑥	Channel complete with 2 x GJS500-7 D 400 ductile iron gratings	165,00	
	4R05SGE	⑦	Channel complete with 2 x GJS500-7 E 600 ductile iron gratings	171,00	E 600
	4R05SGF	⑧	Channel complete with 2 x GJS500-7 F 900 ductile iron gratings	180,64	F 900

R 365 Series accessories

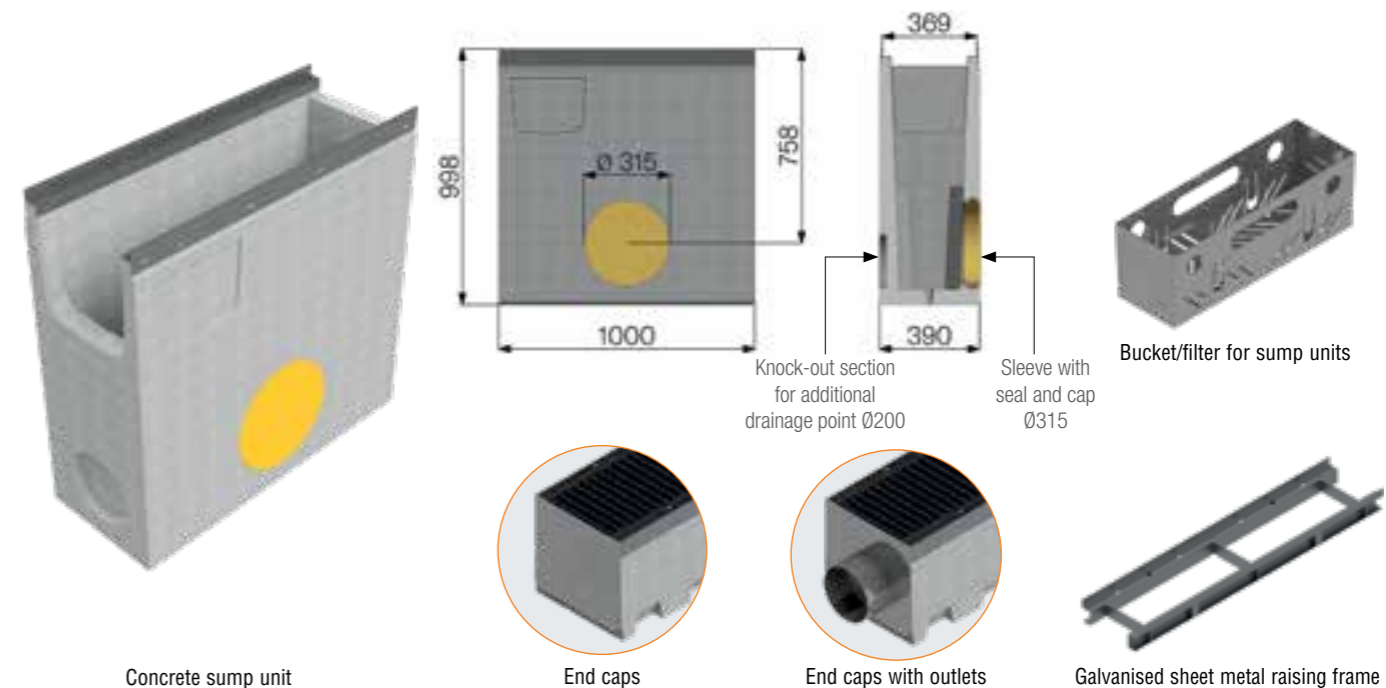

R 365 Series concrete sump unit complete with grating - Length 1000 mm

Sump unit L mm	Code	Grating	Description of the sump unit assembled with the grating complete with accessories	Weight kg	Load class
1000	4R05PZGP	①	Sump unit complete with pressure-locked grating 30x5-10x4 33x33 hot-dip galvanised	385,00	C 250
	4R05PZGPB	②	Sump unit complete with pressure-locked grating 30x5-10x3 33x11 heelguard mesh, hot-dip galvanised	391,00	
	4R05PZGPC	③	Sump unit complete with pressure-locked grating 30x5-10x4 22x66 hot-dip galvanised	392,00	D 400
	4R05PZGPA	④	Sump unit complete with pressure-locked grating 30x4-10x3 15x66 heelguard mesh, hot-dip galvanised	395,00	
	4R05PZP	⑤	Sump unit complete with embossed metal sheet plate 3+2, reinforced and hot-dip galvanised	404,00	
	4R05PZGS	⑥	Sump unit complete with GJS500-7 D 400 ductile iron grating	408,00	
	4R05PZGE	⑦	Sump unit complete with GJS500-7 E 600 ductile iron grating	414,00	E 600
	4R05PZGF	⑧	Sump unit complete with GJS500-7 F 900 ductile iron grating	423,64	F 900

R 365 Series concrete sump unit without grating and accessories

Code	Description	Weight kg
4R05PZ	Reinforced concrete sump unit with galvanised edge rail L= 1000 mm	369,00
4R05VI	Bucket/Filter, AISI 304 stainless steel	4,14
4R05TID	Right-hand end cap for channel closure female side	2,17
4R05TIS	Left-hand end cap for channel closure male side	2,17
4R05RI	End cap with outlet Ø200 mm	2,10
4R05PR	Galvanised sheet metal raising frame for two-stage channel laying	
	Channel bottom drilling Ø250 mm	

R 365 Series channel without grating - Length 1000 mm

Channel L mm	Code	Description	Water passage mm	Run-off section cm ²	Weight kg	Pieces pallet
1000	4R05S	Additivated vibro-compressed concrete R365 channel with galvanised protective edge rails, complying with the UNI EN 1433 standard.	300	835	126,00	9

VIBRO-COMPRESSED CONCRETE CHANNELS **R 495 SERIES**

Grating width 495 mm

Vibro-compressed concrete channel with galvanised protective edge rails. The channels are sold exclusively in complete pallets and together with the gratings.

R 495 Series channel dimensions

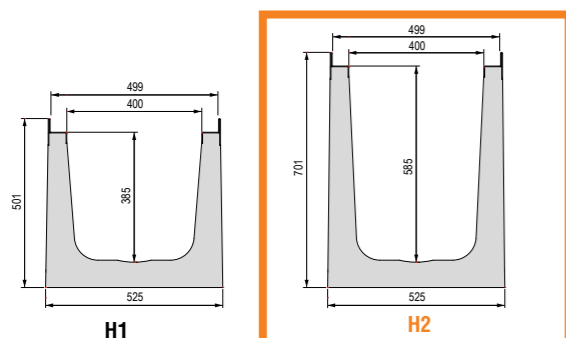
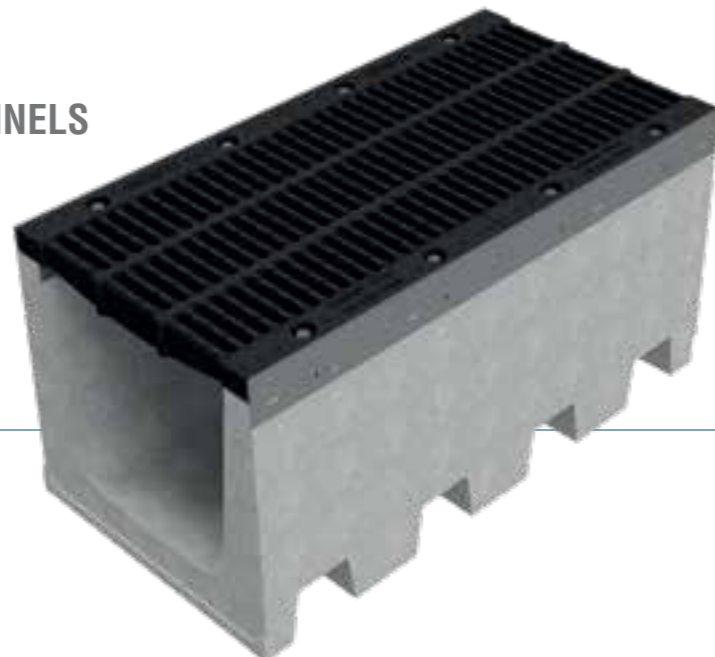

N.B.: the measurements in yellow indicate the heights available only on request

Available gratings N.B.: the gratings in yellow are available only on request



R 495 Series channel complete with grating - Length 1,000

Channel L mm	Code	Grating	Description of the channel assembled with the grating complete with accessories	Weight kg	Load class
1,000	4R10SGPC	①	Channel complete with pressure-locked grating 40x5-10x4 33x33, hot-dip galvanised	260.88	C 250
	4R10SGPB	②	Channel complete with pressure-locked grating 40x5-10x4 33x15 heelguard mesh, hot-dip galvanised	264.70	
	4R10SGP	③	Channel complete with pressure-locked grating 50x5-10x4 22x66, hot-dip galvanised	277.28	D 400
	4R10SGPA	④	Channel complete with pressure-locked grating 40x4-10x4 15x66 heelguard mesh, hot-dip galvanised	273.68	
	4R10SP	⑤	Channel complete with embossed metal sheet plate Th. 5, reinforced and hot-dip galvanised	282.64	
	4R10SGG	⑥	Channel complete with 2 x GJS500-7 ductile iron gratings	295.00	

R 495 Series channel accessories

Code	Accessories	Weight kg	Quantity
4R10TID	Right-hand end cap for channel closure female side	4.53	loose
4R10TIS	Left-hand end cap for channel closure male side	4.60	loose
4R10RI	End cap with outlet Ø300 mm	4.14	loose
4R10BR	Horizontal tracks	6.03	in 3 lm bars
4R10M	Corner brackets	0.28	20
4R10BV	Vertical tracks	4.31	in 3 lm bars
4R10B	Self-locking bush for track	0.05	50
	Channel bottom drilling Ø250 mm		

R 495 Series channel without grating - Length 1,000

Channel L mm	Code	Description	Water passage mm	Run-off section cm ²	Weight kg	Pieces pallet
1,000	4R10S	Additivated vibro-compressed concrete R495 H1 channel with galvanised protective edge rails, complying with the UNI EN 1433 standard.	400	1390	229.00	6
	4R14S	Additivated vibro-compressed concrete R495 H2 channel with galvanised protective edge rails, complying with the UNI EN 1433 standard.	400	2140	276.00	4

VIBRO-COMPRESSED CONCRETE CHANNELS **R 595 SERIES**

Grating width 595 mm

Vibro-compressed concrete channel with galvanised protective edge rails. The channels are sold exclusively in complete pallets and together with the gratings.

R 595 Series channel dimensions

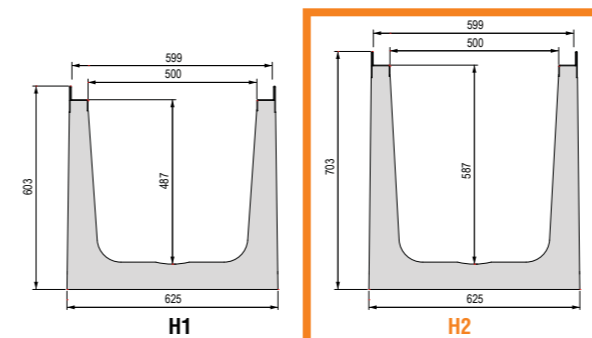
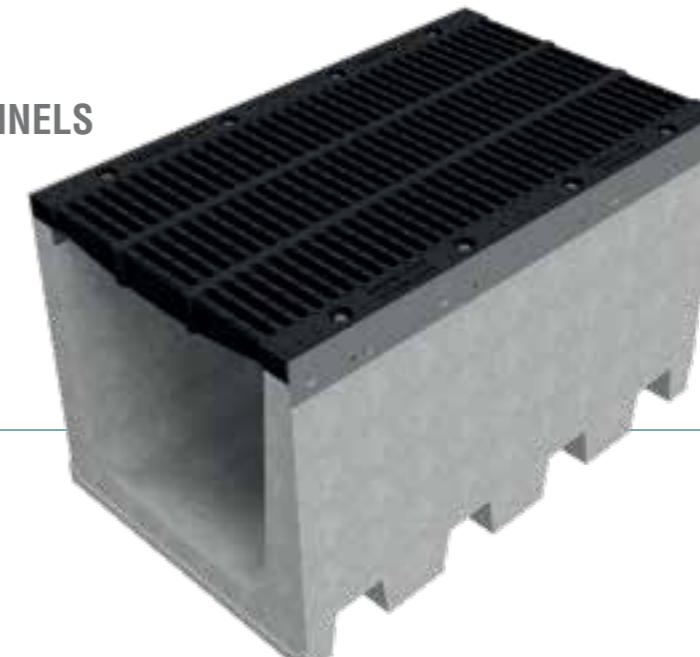

N.B.: the measurements in yellow indicate the heights available only on request

Available gratings N.B.: the gratings in yellow are available only on request



R 595 Series channel complete with grating - Length 1,000

Channel L mm	Code	Grating	Description of the channel assembled with the grating complete with accessories	Weight kg	Load class
1,000	4R15SGP	①	Channel complete with pressure-locked grating 50x5-10x4 33x33, hot-dip galvanised	338.50	C 250
	4R15SGPB	②	Channel complete with pressure-locked grating 50x5-10x4 33x15 heelguard mesh, hot-dip galvanised	342.39	
	4R15SGPC	③	Channel complete with pressure-locked grating 50x5-10x4 22x66, hot-dip galvanised	354.56	D 400
	4R15SGPA	④	Channel complete with pressure-locked grating 50x4-10x4 15x66 heelguard mesh, hot-dip galvanised	357.69	
	4R15SP	⑤	Channel complete with embossed metal sheet plate Th. 5, reinforced and hot-dip galvanised	370.74	
	4R15SGG	⑥	Channel complete with 2 x GJS500-7 ductile iron gratings	412.62	

R 595 Series channel accessories

Code	Accessories	Weight kg	Quantity
4R15TID	Right-hand end cap for channel closure female side	4.75	loose
4R15TIS	Left-hand end cap for channel closure male side	4.81	loose
4R15RI	End cap with outlet Ø300 mm	4.50	loose
4R15BR	Horizontal tracks	6.03	in 3 lm bars
4R10M	Corner brackets	0.28	20
4R15BV	Vertical tracks	4.31	in 3 lm bars
4R10B	Self-locking bush for track	0.05	50
	Channel bottom drilling Ø250 mm		

R 595 Series channel without grating - Length 1,000

Channel L mm	Code	Description	Water passage mm	Run-off section cm ²	Weight kg	Pieces pallet
1,000	4R15S	Additivated vibro-compressed concrete R595 H1 channel with galvanised protective edge rails, complying with the UNI EN 1433 standard.	500	2225	297.00	4
	4R17S	Additivated vibro-compressed concrete R595 H2 channel with galvanised protective edge rails, complying with the UNI EN 1433 standard.	500	2700	343.00	4

VIBRO-COMPRESSED CONCRETE CHANNELS

R 150 SERIES WITH DUCTILE IRON EDGE RAIL

Grating width 150 mm

Vibro-compressed concrete channel with ductile iron edge rails. The channels are sold exclusively in complete pallets and together with the gratings.



R 150 Series channel dimensions with ductile iron edge rail

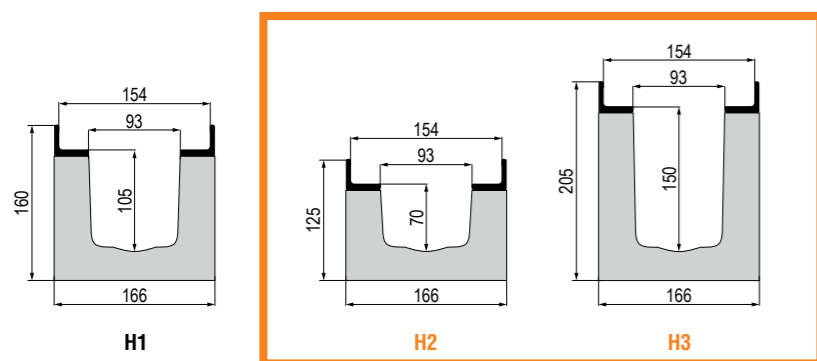

N.B.: the measurements in yellow indicate the heights available only on request

Available gratings



R 150 Series channel with ductile iron edge rail with grating - Length 1000 mm

Channel L mm	Code	Grating	Description of the channel assembled with the grating complete with accessories	Weight kg	Load class
1000	4RG1SGS	①	Channel complete with 2 x GJS500-7 D 400 ductile iron gratings	47,00	D 400
	4RG1SGE	②	Channel complete with 2 x GJS500-7 E 600 ductile iron gratings	47,20	E 600
	4RG1SGF	③	Channel complete with 2 x GJS500-7 F 900 ductile iron gratings	48,94	F 900

R 150 Series accessories with ductile iron edge rail

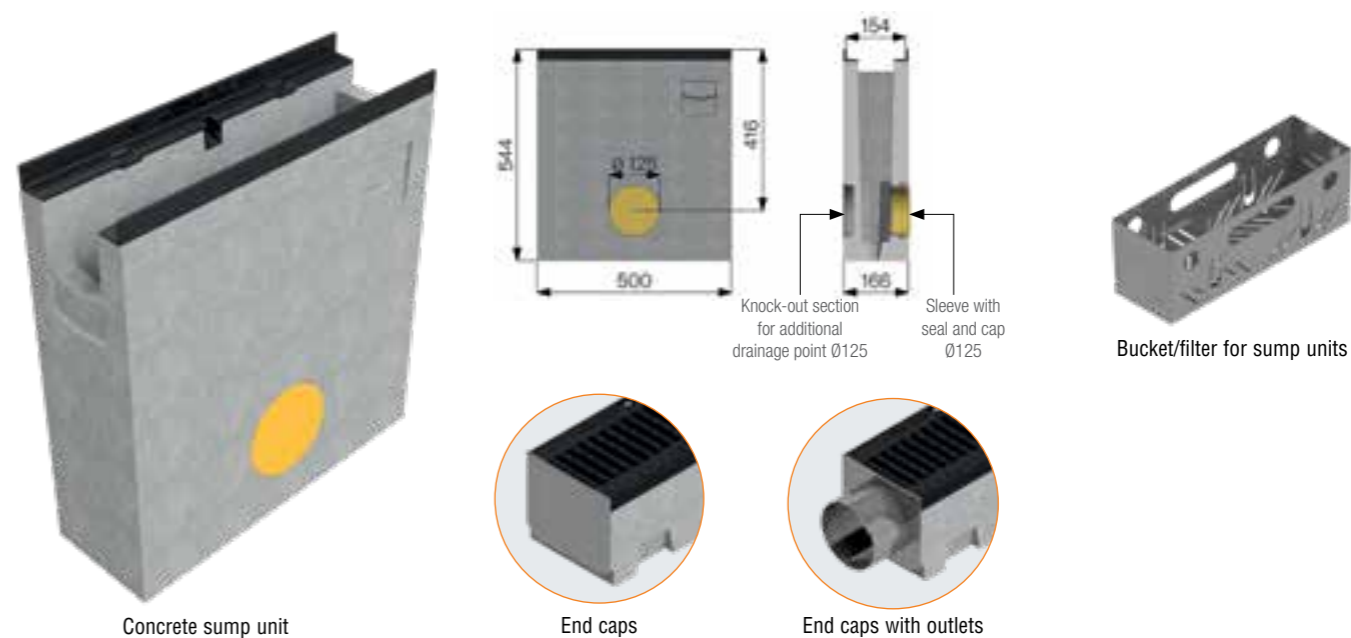

R 150 Series concrete sump unit complete with ductile iron edge rail with grating - Length 500 mm

Sump unit L mm	Code	Grating	Description of the sump unit assembled with the grating complete with accessories	Weight kg	Load class
500	4RG1PZGS	①	Sump unit complete with GJS500-7 D 400 ductile iron inlay grating	72,48	D 400
	4RG1PZGE	②	Sump unit complete with GJS500-7 E 600 ductile iron inlay grating	72,60	E 600
	4RG1PZGF	③	Sump unit complete with GJS500-7 F 900 ductile iron inlay grating	73,49	F 900

R 150 Series concrete sump unit with ductile iron edge rail without grating and accessories

Code	Description	Weight kg
4RG1PZ	Reinforced concrete sump unit with ductile iron edge rail L=500	68,20
4R01VI	Bucket/Filter, AISI 304 stainless steel	1,16
4R01TID	Right-hand end cap for channel closure female side	0,30
4R01TIS	Left-hand end cap for channel closure male side	0,30
4R01RI	End cap with outlet Ø200 mm	0,52
	Channel bottom drilling Ø75 mm	

R 150 Series channel with ductile iron edge rail without grating - Length 1000

Channel L mm	Code	Description	Water passage mm	Run-off section cm ²	Weight kg	Pieces pallet
1000	4RG1S	Additivated vibro-compressed concrete 150 H1 channel with ductile iron edge rails, complying with the UNI EN 1433 standard.	93	90	38,36	36
	4RG11S	Additivated vibro-compressed concrete 150 H2 channel with ductile iron edge rails, complying with the UNI EN 1433 standard.	93	60	31,50	42
	4RG12S	Additivated vibro-compressed concrete 150 H3 channel with ductile iron edge rails, complying with the UNI EN 1433 standard.	93	133	46,00	30

VIBRO-COMPRESSED CONCRETE CHANNELS

R 210 SERIES WITH DUCTILE IRON EDGE RAIL

Grating width 210 mm

Vibro-compressed concrete channel with ductile iron edge rails. The channels are sold exclusively in complete pallets and together with the gratings.



R 210 Series channel dimensions with ductile iron edge rail

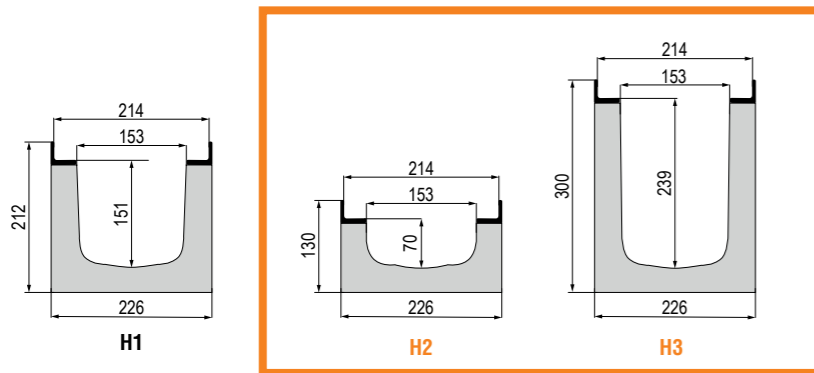

N.B.: the measurements in yellow indicate the heights available only on request

Available gratings



R 210 Series channel with ductile iron edge rail with grating - Length 1000 mm

Channel L mm	Code	Grating	Description of the channel assembled with the grating complete with accessories	Weight kg	Load class
1000	4RG2SGS	①	Channel complete with 2 x GJS500-7 D 400 ductile iron gratings	62,44	D 400
	4RG2SGE	②	Channel complete with 2 x GJS500-7 E 600 ductile iron gratings	68,96	E 600
	4RG2SGF	③	Channel complete with 2 x GJS500-7 F 900 ductile iron gratings	73,59	F 900

R 210 Series accessories with ductile iron edge rail



Concrete sump unit

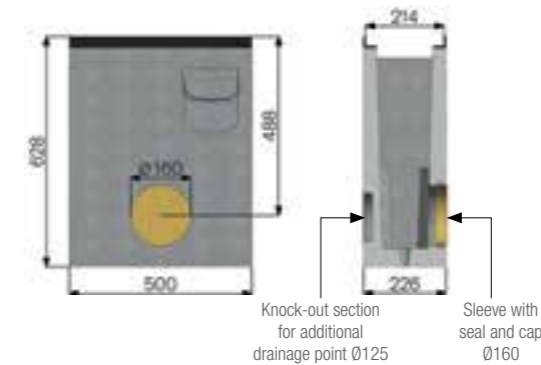

End caps

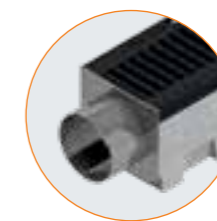

End caps with outlets



Bucket/filter for sump units

R 210 Series concrete sump unit complete with ductile iron edge rail with grating - Length 500 mm

Sump unit L mm	Code	Grating	Description of the sump unit assembled with the grating complete with accessories	Weight kg	Load class
500	4RG2PZGS	①	Sump unit complete with GJS500-7 D 400 ductile iron inlay grating	89,06	D 400
	4RG2PZGE	②	Sump unit complete with GJS500-7 E 600 ductile iron inlay grating	90,20	E 600
	4RG2PZGF	③	Sump unit complete with GJS500-7 F 900 ductile iron inlay grating	92,62	F 900

R 210 Series concrete sump unit with ductile iron edge rail without grating and accessories

Code	Description	Weight kg
4RG2PZ	Reinforced concrete sump unit with ductile iron edge rail L 500 mm	82,80
4R02VI	Bucket/Filter, AISI 304 stainless steel	1,50
4R02TID	Right-hand end cap for channel closure female side	0,53
4R02TIS	Left-hand end cap for channel closure male side	0,53
4R02RI	End cap with outlet Ø156 mm	1,30
	Channel bottom drilling Ø125 mm	

R 210 Series channel with ductile iron edge rail without grating - Length 1000 mm

Channel L mm	Code	Description	Water passage mm	Run-off section cm ²	Weight kg	Pieces pallet
1000	4RG2S	Additivated vibro-compressed concrete R210 H1 channel with ductile iron edge rails, complying with the UNI EN 1433 standard.	153	216	53,88	20
	4RG21S	Additivated vibro-compressed concrete R210 H2 channel with ductile iron edge rails, complying with the UNI EN 1433 standard.	153	95	39,22	25
	4RG22S	Additivated vibro-compressed concrete R210 H3 channel with ductile iron edge rails, complying with the UNI EN 1433 standard.	153	350	64,34	20

VIBRO-COMPRESSED CONCRETE CHANNELS

R 265 SERIES WITH DUCTILE IRON EDGE RAIL

Grating width 265 mm

Vibro-compressed concrete channel with ductile iron edge rails. The channels are sold exclusively in complete pallets and together with the gratings.



R 265 Series channel dimensions with ductile iron edge rail

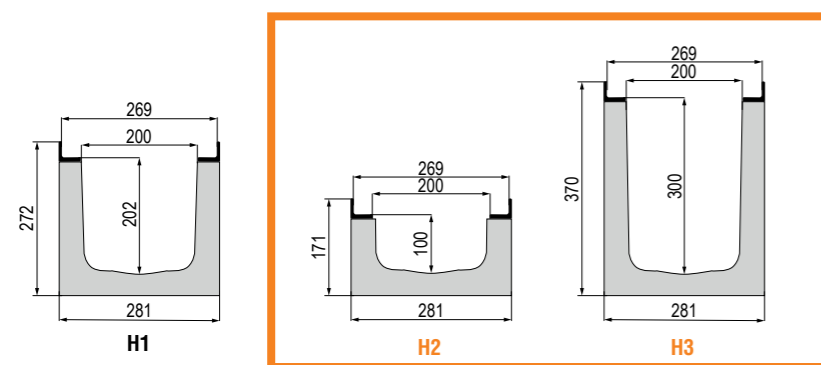

N.B.: the measurements in yellow indicate the heights available only on request

Available gratings



R 265 Series channel with ductile iron edge rail with grating - Length 1000 mm

Channel L mm	Code	Grating	Description of the channel assembled with the grating complete with accessories	Weight kg	Load class
1000	4RG3SGS	①	Channel complete with 2 x GJS500-7 D 400 ductile iron gratings	92,70	D 400
	4RG3SGE	②	Channel complete with 2 x GJS500-7 E 600 ductile iron gratings	100,80	E 600
	4RG3SGF	③	Channel complete with 2 x GJS500-7 F 900 ductile iron gratings	102,58	F 900

R 265 Series accessories with ductile iron edge rail

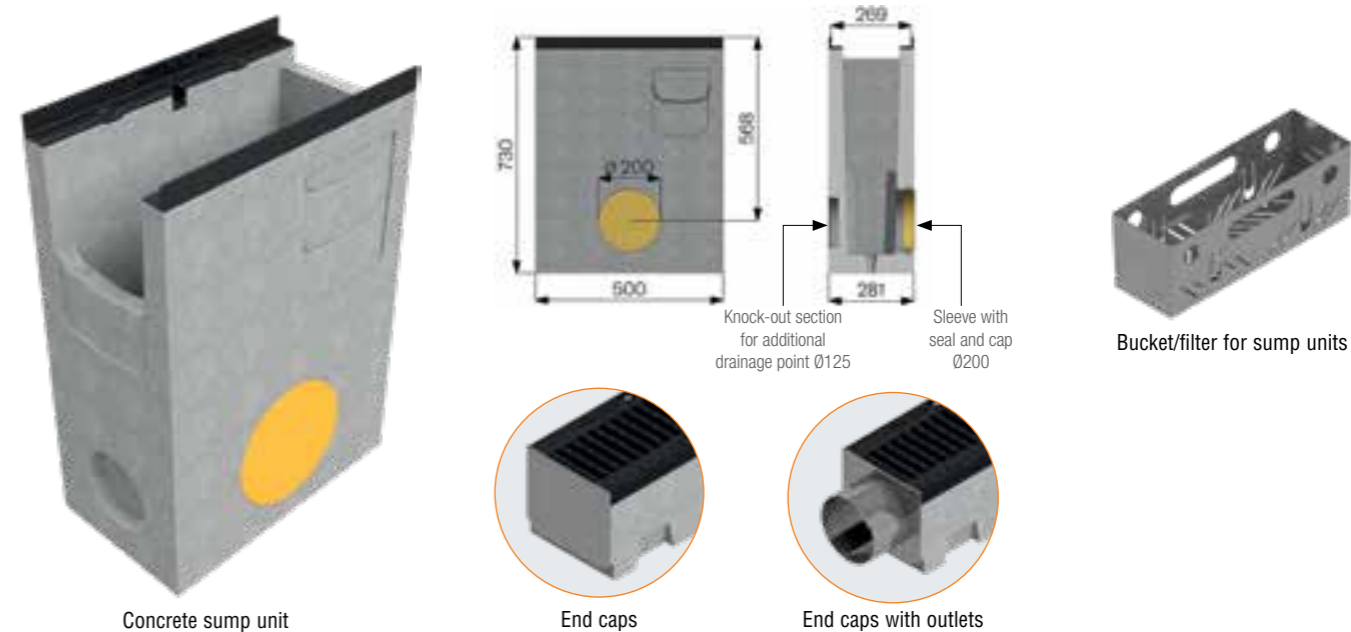

R 265 Series concrete sump unit complete with ductile iron edge rail with grating - Length 500 mm

Sump unit L mm	Code	Grating	Description of the sump unit assembled with the grating complete with accessories	Weight kg	Load class
500	4RG3PZGS	①	Sump unit complete with GJS500-7 D 400 ductile iron inlay grating	118,70	D 400
	4RG3PZGE	②	Sump unit complete with GJS500-7 E 600 ductile iron inlay grating	121,86	E 600
	4RG3PZGF	③	Sump unit complete with GJS500-7 F 900 ductile iron inlay grating	122,80	F 900

R 265 Series concrete sump unit with ductile iron edge rail without grating and accessories

Code	Description	Weight kg
4RG3PZ	Reinforced concrete sump unit with ductile iron edge rail L 500 mm	109,80
4R03VI	Bucket/Filter, AISI 304 stainless steel	1,71
4R03TID	Right-hand end cap for channel closure female side	1,11
4R03TIS	Left-hand end cap for channel closure male side	1,11
4R03RI	End cap with outlet Ø156 mm	1,81
	Channel bottom drilling Ø160 mm	

R 265 Series channel with ductile iron edge rail without grating - Length 1000 mm

Channel L mm	Code	Description	Water passage mm	Run-off section cm ²	Weight kg	Pieces pallet
1000	4RG3S	Additivated vibro-compressed concrete R265 H1 channel with ductile iron edge rails, complying with the UNI EN 1433 standard	200	376	74,90	16
	4RG31S	Additivated vibro-compressed concrete R265 H2 channel with ductile iron edge rails, complying with the UNI EN 1433 standard	200	183	55,90	24
	4RG32S	Additivated vibro-compressed concrete R265 H3 channel with ductile iron edge rails, complying with the UNI EN 1433 standard	200	577	96,00	12

VIBRO-COMPRESSED CONCRETE CHANNELS

R 315 SERIES WITH DUCTILE IRON EDGE RAIL

Grating width 315 mm

Vibro-compressed concrete channel with ductile iron edge rails.
The channels are sold exclusively in complete pallets and together with the gratings.



R 315 Series channel dimensions with ductile iron edge rail

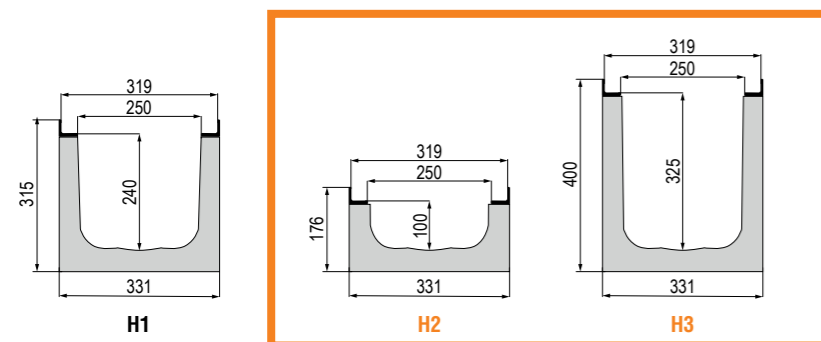

N.B.: the measurements in yellow indicate the heights available only on request

Available gratings



R 315 Series channel with ductile iron edge rail with grating - Length 1000 mm

Channel L mm	Code	Grating	Description of the channel assembled with the grating complete with accessories	Weight kg	Load class
1000	4RG4SGS	①	Channel complete with 2 x GJS500-7 D 400 ductile iron gratings	123,00	D 400
	4RG4SGE	②	Channel complete with 2 x GJS500-7 E 600 ductile iron gratings	128,70	E 600
	4RG4SGF	③	Channel complete with 2 x GJS500-7 F 900 ductile iron gratings	135,40	F 900

R 315 Series accessories with ductile iron edge rail

Code	Description	Weight kg
4R04TID	Right-hand end cap for channel closure female side	1,52
4R04TIS	Left-hand end cap for channel closure male side	1,52
4R04RI	End cap with outlet Ø200 mm	1,90
	Channel bottom drilling Ø200 mm	

R 315 Series channel with ductile iron edge rail without grating - Length 1000 mm

Channel L mm	Code	Description	Water passage mm	Run-off section cm ²	Weight kg	Pieces pallet
1000	4RG4S	Additivated vibro-compressed concrete R315 H1 channel with ductile iron edge rails, complying with the UNI EN 1433 standard	250	562	93,30	9
	4RG41S	Additivated vibro-compressed concrete R315 H2 channel with ductile iron edge rails, complying with the UNI EN 1433 standard	250	224	66,40	15
	4RG42S	Additivated vibro-compressed concrete R315 H3 channel with ductile iron edge rails, complying with the UNI EN 1433 standard	250	778	111,75	4



VIBRO-COMPRESSED CONCRETE CHANNELS

R 365 SERIES WITH DUCTILE IRON EDGE RAIL

Grating width 365 mm

Vibro-compressed concrete channel with ductile iron edge rails. The channels are sold exclusively in complete pallets and together with the gratings.



R 365 Series channel dimensions with ductile iron edge rail

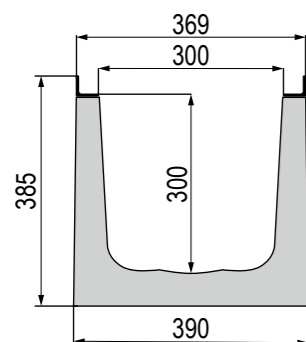

Available gratings



R 365 Series channel with ductile iron edge rail with grating - Length 1000 mm

Channel L mm	Code	Grating	Description of the channel assembled with the grating complete with accessories	Weight kg	Load class
1000	4RG5SGS	①	Channel complete with 2 x GJS500-7 D 400 ductile iron gratings	169,00	D 400
	4RG5SGE	②	Channel complete with 2 x GJS500-7 E 600 ductile iron gratings	175,00	E 600
	4RG5SGF	③	Channel complete with 2 x GJS500-7 F 900 ductile iron gratings	184,64	F 900

R 365 Series accessories with ductile iron edge rail

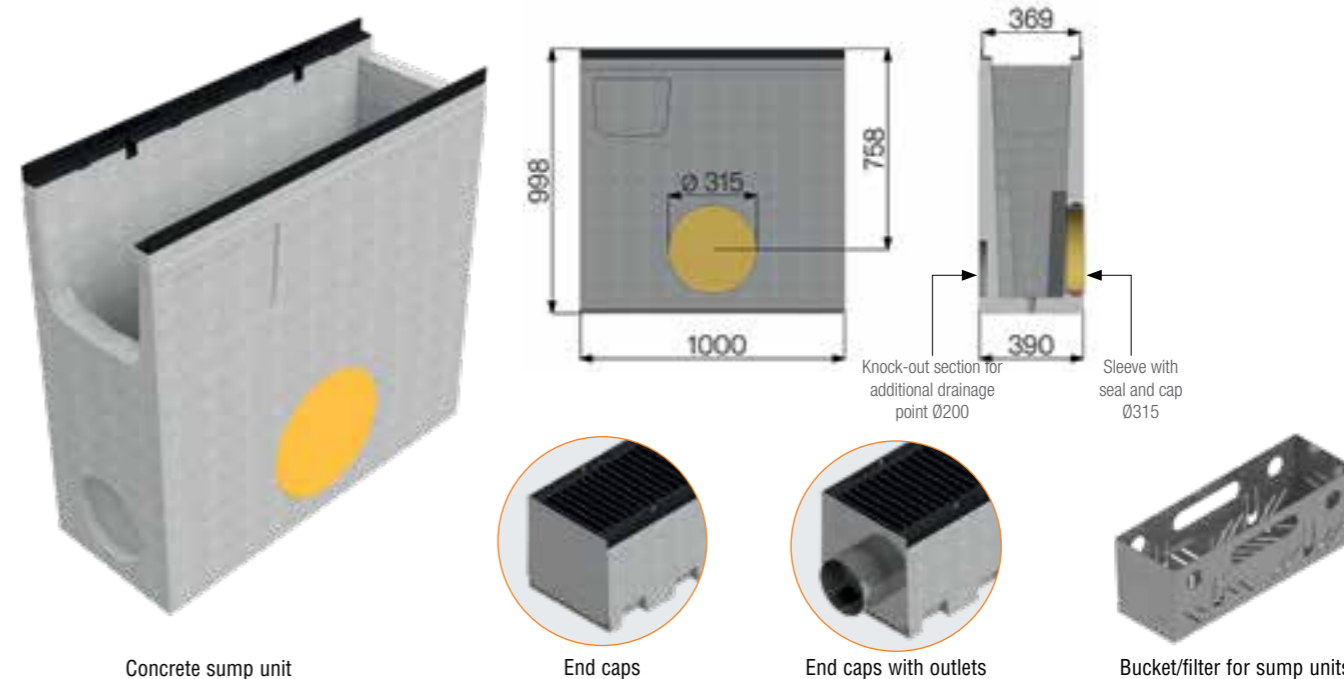

R 365 Series concrete sump unit complete with ductile iron edge rail with grating - Length 1000 mm

Sump unit L mm	Code	Grating	Description of the sump unit assembled with the grating complete with accessories	Weight kg	Load class
1000	4RG5PZGS	①	Sump unit complete with GJS500-7 D 400 ductile iron inlay grating	412,00	D 400
	4RG5PZGE	②	Sump unit complete with GJS500-7 E 600 ductile iron inlay grating	418,00	E 600
	4RG5PZGF	③	Sump unit complete with GJS500-7 F 900 ductile iron inlay grating	427,64	F 900

R 365 Series concrete sump unit with ductile iron edge rail without grating and accessories

Code	Description	Weight kg
4RG5PZ	Reinforced concrete sump unit with ductile iron edge rail L=1000	373,00
4R05VI	Bucket/Filter, AISI 304 stainless steel	4,14
4R05TID	Right-hand end cap for channel closure female side	2,17
4R05TIS	Left-hand end cap for channel closure male side	2,17
4R05RI	End cap with outlet Ø200 mm	2,10
	Channel bottom drilling Ø250 mm	

R 365 Series channel with ductile iron edge rail without grating - Length 1000 mm

Channel L mm	Code	Description	Water passage mm	Run-off section cm ²	Weight kg	Pieces pallet
1000	4RG5S	Additivated vibro-compressed concrete R365 channel with ductile iron edge rails, complying with the UNI EN 1433 standard.	300	835	130,00	9

[®]
GRIDIRON

**CHANNELS MADE OF
REINFORCED
CONCRETE**

REINFORCED CONCRETE
CHANNELS

PAGE
80
K SERIES

PAGE
90
C SERIES

PAGE
98
XL SERIES



GRIDIRON[®]
BUILD YOUR CHANGES

K

SERIES

REINFORCED CONCRETE CHANNELS

REINFORCED CONCRETE CHANNELS

Reinforced concrete channels adopt the effective and patented grating locking system. The sturdy ductile iron edge rails – inserted into the concrete and connected to channel's metal reinforcement structure – greatly enhance the structure's resistance, and their bare finish blends in perfectly with the ductile iron gratings.

The channels are easy and quick to install: the ductile iron gratings are inserted into the relevant anchoring elements and locked with a single stainless steel bolt on each grid.

With this system, inspection operations can be carried out quickly and easily. The K series channels are designed for all situations requiring high load-bearing capacities and finishes that can blend into particularly refined urban settings.

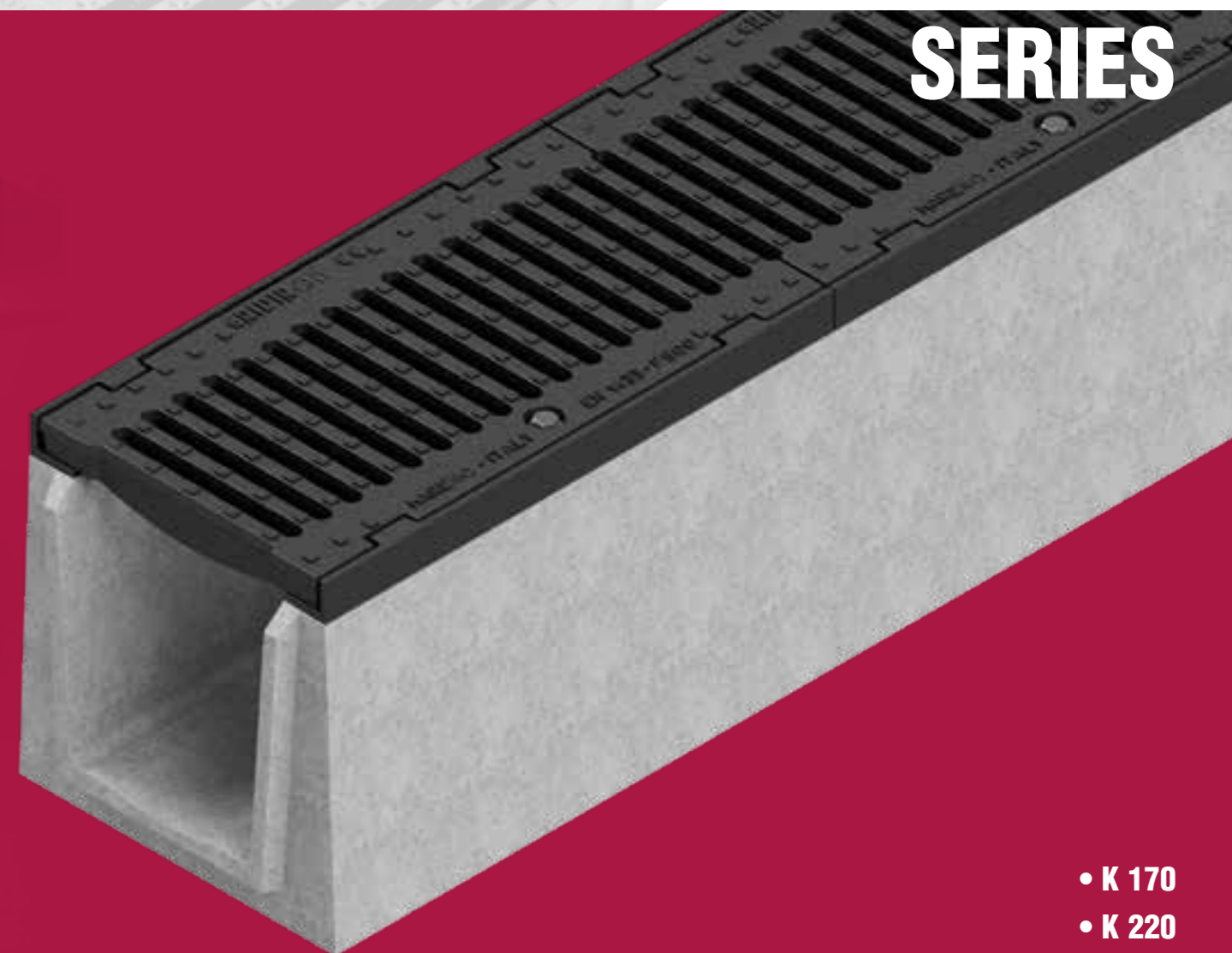

- K 170
- K 220
- K 270
- K 270 LOWERED
- K 350
- K 400

LOAD CLASSES

In accordance with the UNI EN 1433 standard



F 900

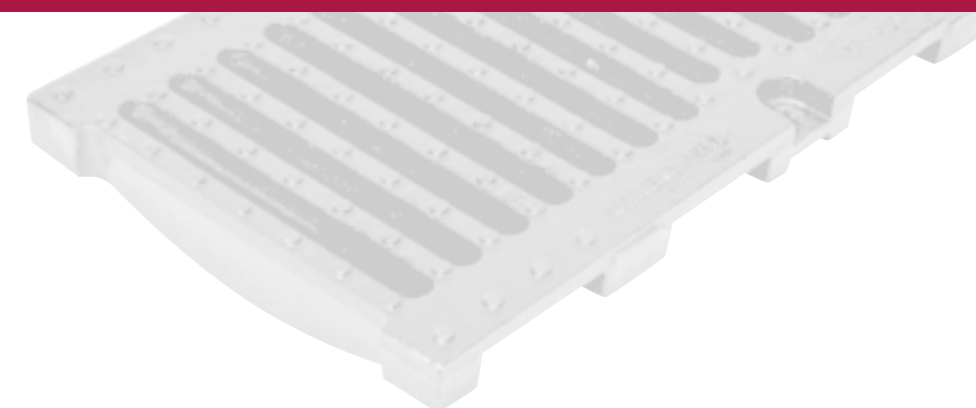

REINFORCED CONCRETE CHANNELS

K SERIES

TECHNICAL CHARACTERISTICS

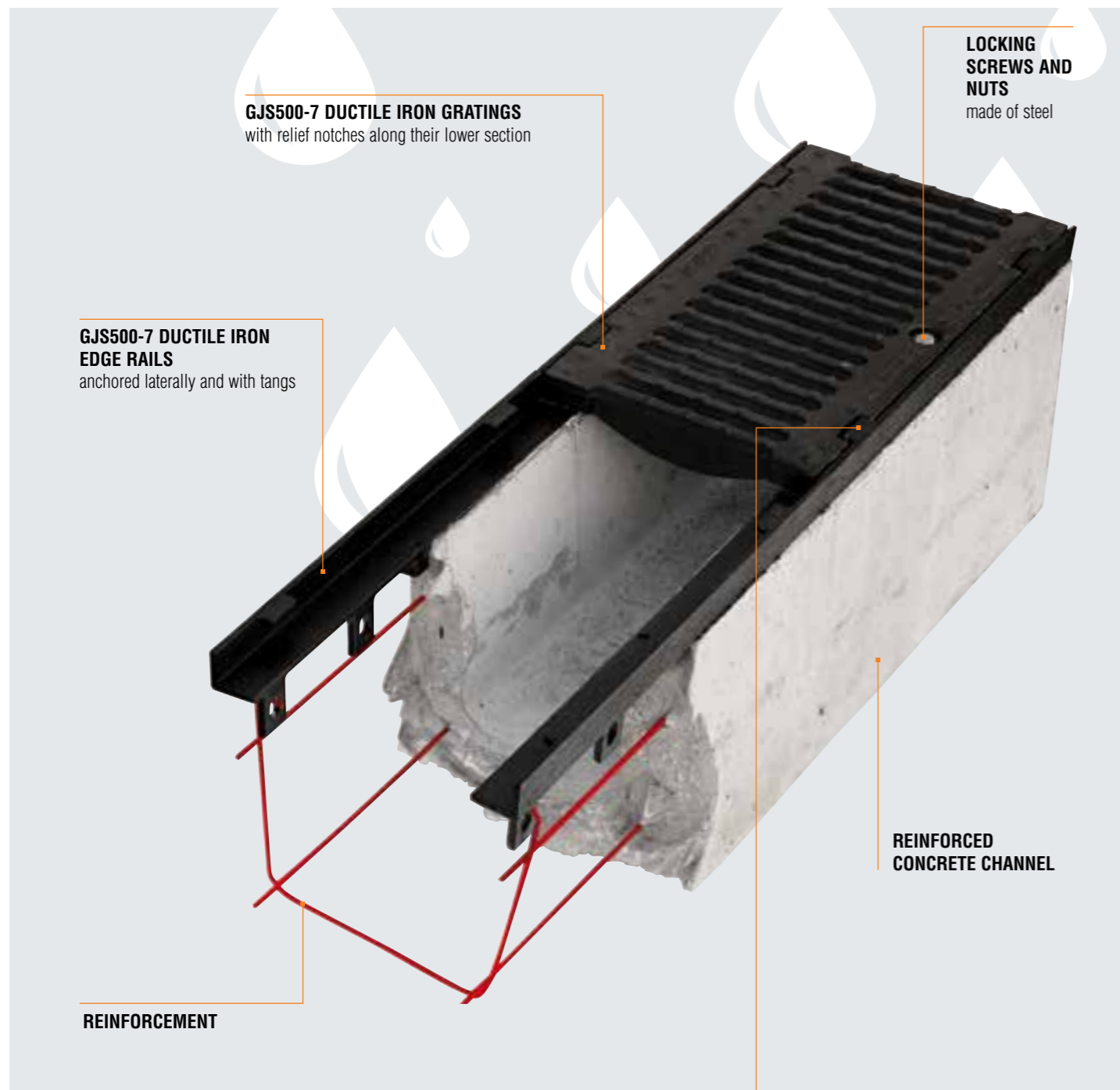

K SERIES CHANNELS

Compressive strength: roughly 600 kg/cm²

Tensile strength: roughly 50 kg/cm²

Water absorption: between 1% and 3%

PATENTED LOCKING SYSTEM

The sturdy ductile iron edge rails – inserted into the concrete and connected to channel's metal reinforcement structure – greatly enhance the structure's resistance, and their bare finish blends in perfectly with the ductile iron gratings.



REINFORCED CONCRETE CHANNELS

K 170 SERIES

Grating width 170 mm

Reinforced concrete channel and GJS500-7 ductile iron grating equipped with locking system complying with the UNI EN 1433 standard.

The channels are sold exclusively in complete pallets and together with the gratings.

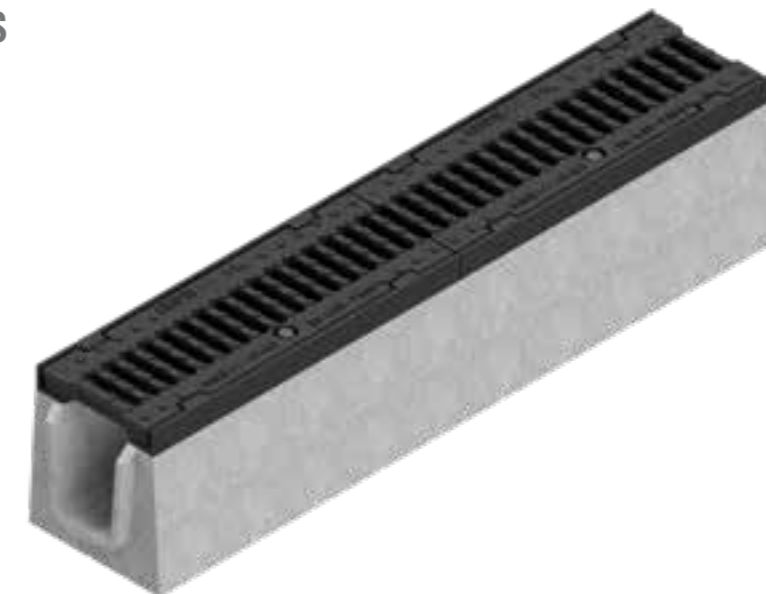

K 170 Series channel dimensions

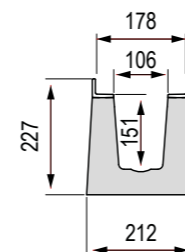

Available grating



K 170 Series channel complete with grating - Length 1,000

Channel L mm	Code	Description	Water passage mm	Run-off section cm ²	Weight kg	Pieces pallet	Load class
1,000	4S05S	Reinforced concrete channel with 172 mm grating made of GJS500-7 ductile iron	106	135	95.58	20	F 900

K 170 Series channel accessories

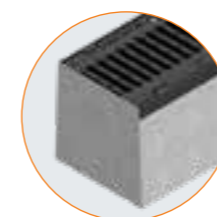

Right-hand end cap

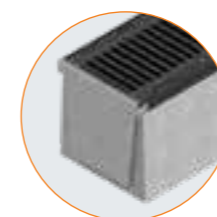

Left-hand end cap

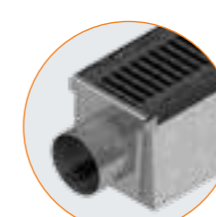

End caps with outlets

Code	Accessories	Weight kg
4S05TID	Right-hand end cap for channel closure female side	0.35
4S05TIS	Left-hand end cap for channel closure male side	0.35
4S05RI	End cap with outlet Ø76 mm	0.58
4S05SF	Channel with perforated bottom Ø82 mm	95.00

REINFORCED CONCRETE CHANNELS **K 220 SERIES**

Grating width 220 mm

Reinforced concrete channel and GJS500-7 ductile iron grating equipped with locking system complying with the UNI EN 1433 standard.

The channels are sold exclusively in complete pallets and together with the gratings.



K 220 Series channel dimensions

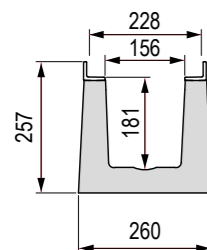

Available grating



GJS500-7 ductile iron grating
F 900

K 220 Series channel complete with grating - Length 1,000

Channel L mm	Code	Description	Water passage mm	Run-off section cm ²	Weight kg	Pieces pallet	Load class
1,000	4U05S	Reinforced concrete channel with 222 mm grating made of GJS500-7 ductile iron	156	243	120.42	16	F 900

K 220 Series channel accessories

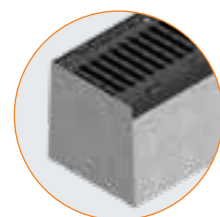

Right-hand end cap

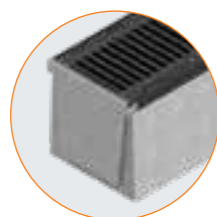

Left-hand end cap

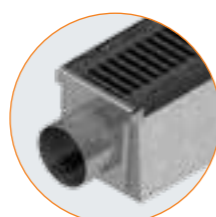

End caps with outlets

Code	Accessories	Weight kg
4U05TID	Right-hand end cap for channel closure female side	0.63
4U05TIS	Left-hand end cap for channel closure male side	0.63
4U05RI	End cap with outlet Ø156 mm	1.25
4U05SF	Channel with perforated bottom Ø132 mm	119.70

REINFORCED CONCRETE CHANNELS **K 270 SERIES**

Grating width 270 mm

Reinforced concrete channel and GJS500-7 ductile iron grating equipped with locking system complying with the UNI EN 1433 standard.

The channels are sold exclusively in complete pallets and together with the gratings.



K 270 Series channel dimensions

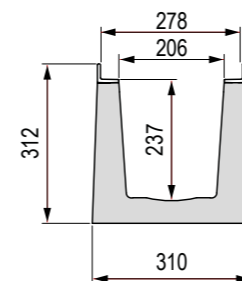

Available grating



GJS500-7 ductile iron grating
F 900

K 270 Series channel complete with grating - Length 1,000

Channel L mm	Code	Description	Water passage mm	Run-off section cm ²	Weight kg	Pieces pallet	Load class
1,000	4V05S	Reinforced concrete channel with 272 mm grating made of GJS500-7 ductile iron	206	419	161.40	9	F 900

K 270 Series channel accessories

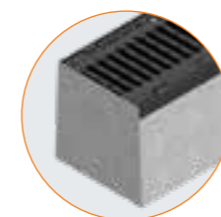

Right-hand end cap

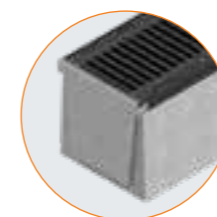

Left-hand end cap

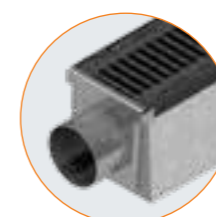

End caps with outlets

Code	Accessories	Weight kg
4V05TID	Right-hand end cap for channel closure female side	0.78
4V05TIS	Left-hand end cap for channel closure male side	0.78
4V05RI	End cap with outlet Ø156 mm	1.55
4V05SF	Channel with perforated bottom Ø162 mm	158.74

REINFORCED CONCRETE CHANNELS **K 270 SERIES lowered**

Grating width 270 mm

Reinforced concrete channel and GJS500-7 ductile iron grating equipped with locking system complying with the UNI EN 1433 standard.

The channels are sold exclusively in complete pallets and together with the gratings.



K 270 Series lowered channel dimensions

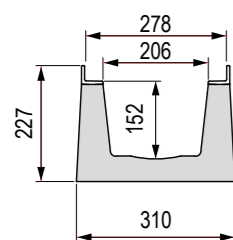

Available grating



GJS500-7 ductile iron grating
F 900

K 270 Series lowered channel complete with grating - Length 1,000

Channel L mm	Code	Description	Water passage mm	Run-off section cm ²	Weight kg	Pieces pallet	Load class
1,000	4V06S	Reinforced concrete channel with 272 mm grating made of GJS500-7 ductile iron	206	201	115.70	15	F 900

K 270 Series lowered channel accessories

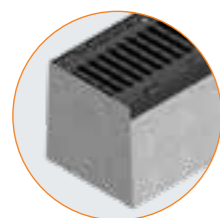

Right-hand end cap

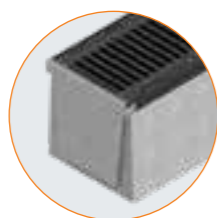

Left-hand end cap

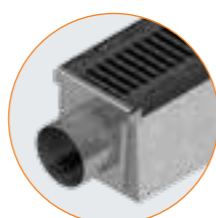

End caps with outlets

Code	Accessories	Weight kg
4V06TID	Right-hand end cap for channel closure female side	0.72
4V06TIS	Left-hand end cap for channel closure male side	0.72
4V06RI	End cap with outlet Ø156 mm	1.48
4V06SF	Channel with perforated bottom Ø162 mm	114.00

REINFORCED CONCRETE CHANNELS **K 350 SERIES**

Grating width 350 mm

Reinforced concrete channel and GJS500-7 ductile iron grating equipped with locking system complying with the UNI EN 1433 standard.

The channels are sold exclusively in complete pallets and together with the gratings.

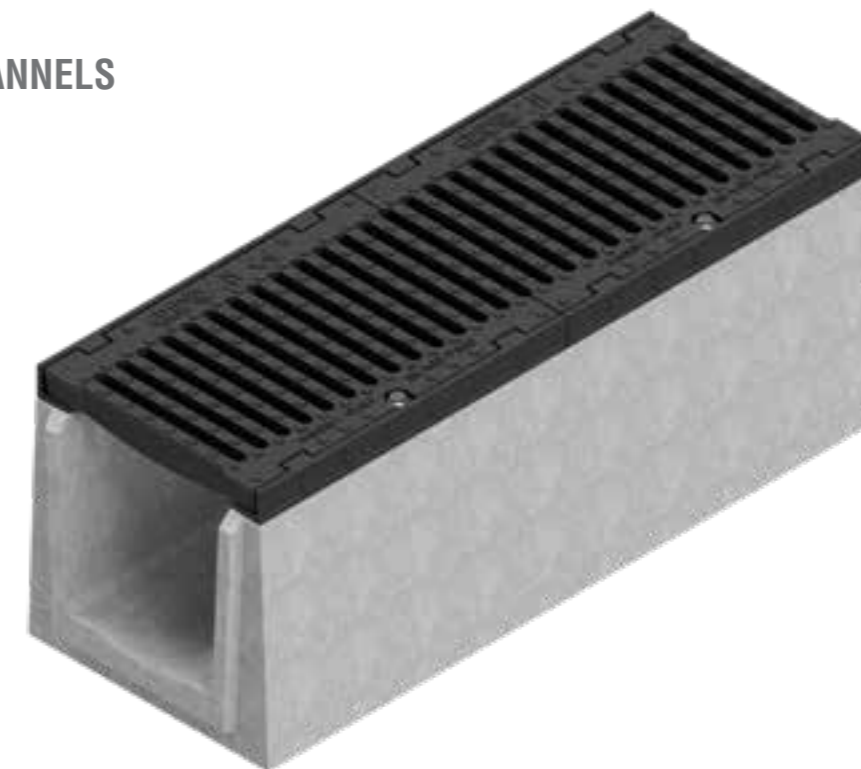

K 350 Series channel dimensions

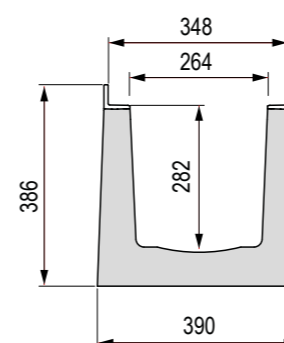

Available grating



GJS500-7 ductile iron grating
F 900

K 350 Series channel complete with grating - Length 1,000

Channel L mm	Code	Description	Water passage mm	Run-off section cm ²	Weight kg	Pieces pallet	Load class
1,000	4K05S	Reinforced concrete channel with 350 mm grating made of GJS500-7 ductile iron	264	691	242	9	F 900

K 350 Series channel accessories

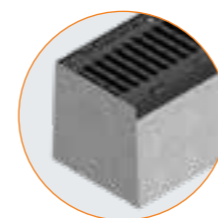

Right-hand end cap

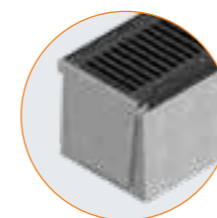

Left-hand end cap

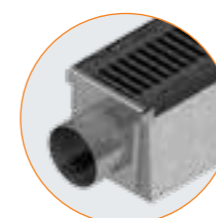

End caps with outlets

Code	Accessories	Weight kg
4K05TID	Right-hand end cap for channel closure female side	1.06
4K05TIS	Left-hand end cap for channel closure male side	1.06
4K05RI	End cap with outlet Ø204 mm	2.02
4K05SF	Channel with perforated bottom Ø202 mm	238.00

REINFORCED CONCRETE CHANNELS **K 400 SERIES**

Grating width 400 mm

Reinforced concrete channel and GJS500-7 ductile iron grating equipped with locking system complying with the UNI EN 1433 standard. The channels are sold exclusively in complete pallets and together with the gratings.

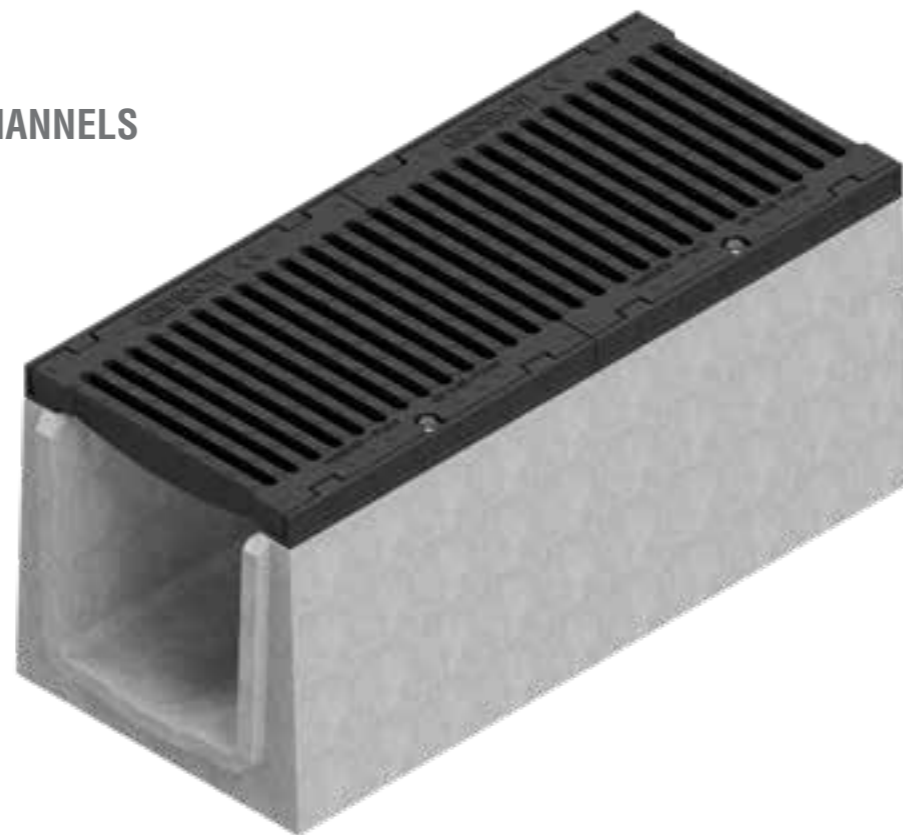

K 400 Series channel dimensions

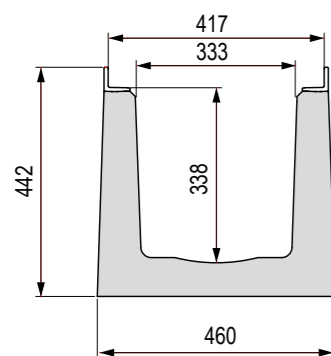

Available grating



GJS500-7 ductile iron grating
F 900

K 400 Series channel complete with grating - Length 1,000

Channel L mm	Code	Description	Water passage mm	Run-off section cm ²	Weight kg	Pieces pallet	Load class
1,000	4K10S	Reinforced concrete channel with 400 mm grating made of GJS500-7 ductile iron	333	977	302	6	F 900

K 400 Series channel accessories

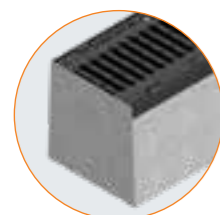

Right-hand end cap

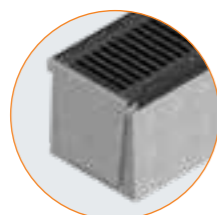

Left-hand end cap

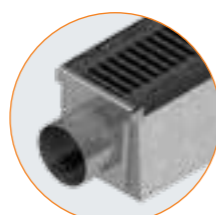

End caps with outlets

Code	Accessories	Weight kg
4K10TID	Right-hand end cap for channel closure female side	1.36
4K10TIS	Left-hand end cap for channel closure male side	1.36
4K10RI	End cap with outlet Ø204 mm	2.80
4K10SF	Channel with perforated bottom Ø202 mm	298.00



C

SERIES

REINFORCED CONCRETE CHANNELS

REINFORCED CONCRETE CHANNELS

The innovative reinforced concrete channels with galvanised edge rails offer a new solution for all heavy-duty applications. They are able to drain large amounts of water thanks to their large dimensions, and their excellent resistance makes them capable of sustaining the transit of heavy vehicles.

They are offered in conjunction with:

- 1) **forge-welded and hot-dip galvanised gratings**
- 2) **embossed metal sheet plates reinforced with grid**
- 3) **reinforced concrete cover (available only on request)**

The gratings and plates can be easily locked using the stainless steel bolts provided, guaranteeing maximum safety.

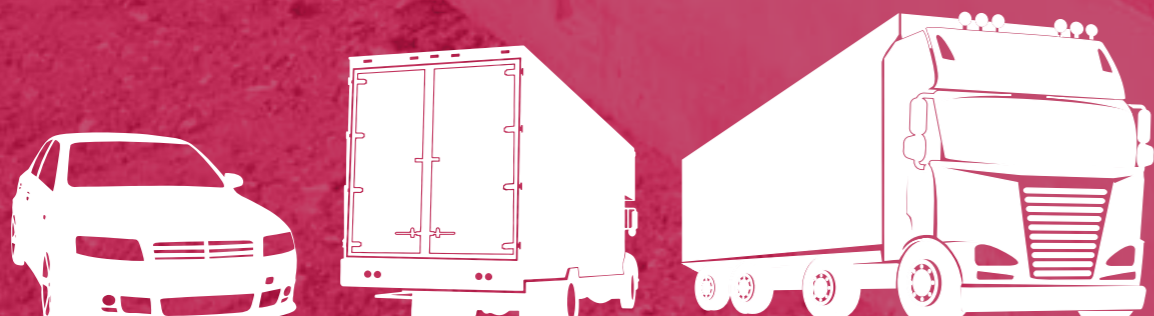
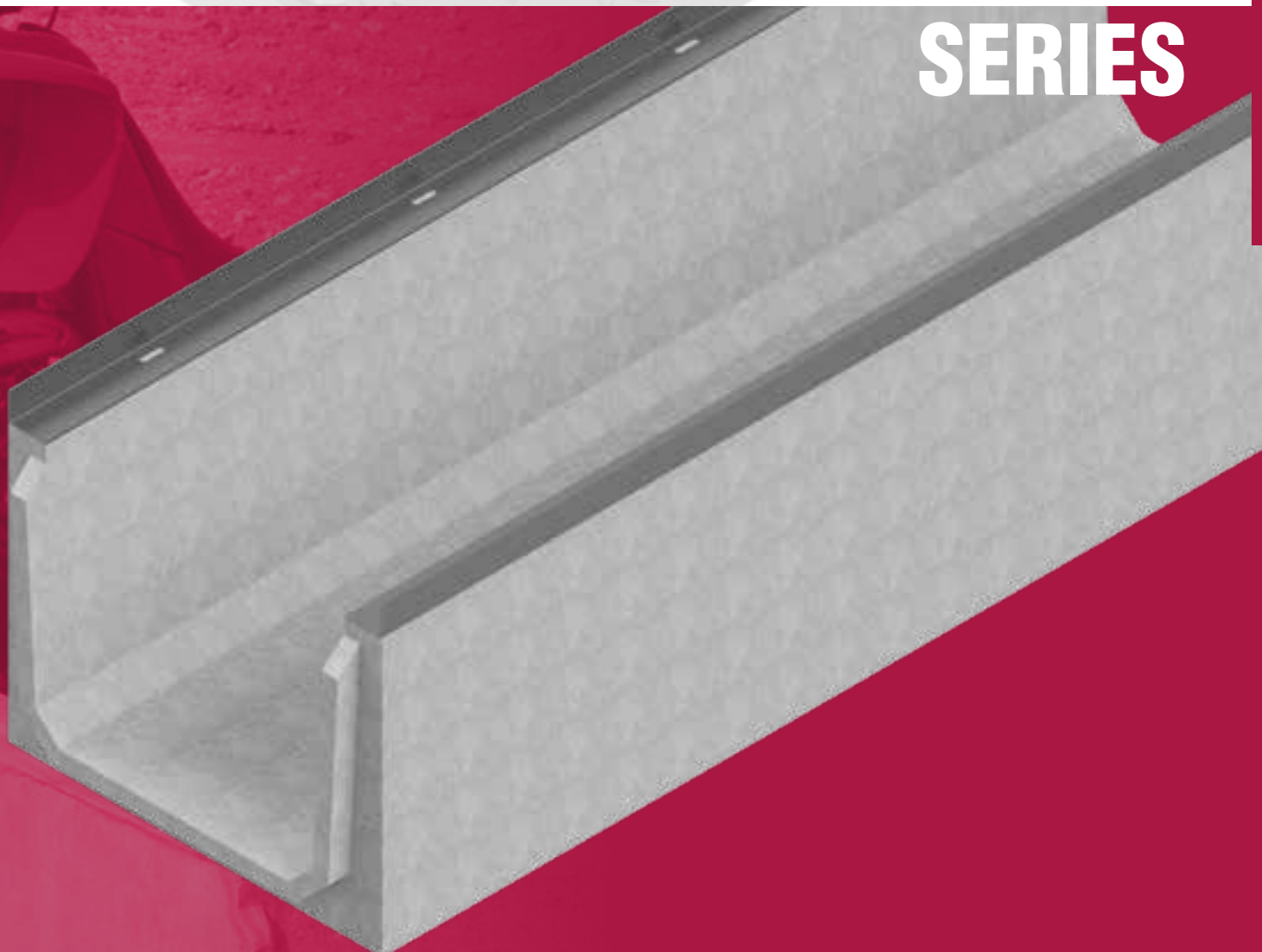

- C 500
- C 600
- C 700
- C 800

LOAD CLASSES

In accordance with the UNI EN 1433 standard



D 400

REINFORCED CONCRETE CHANNELS

C SERIES

TECHNICAL CHARACTERISTICS

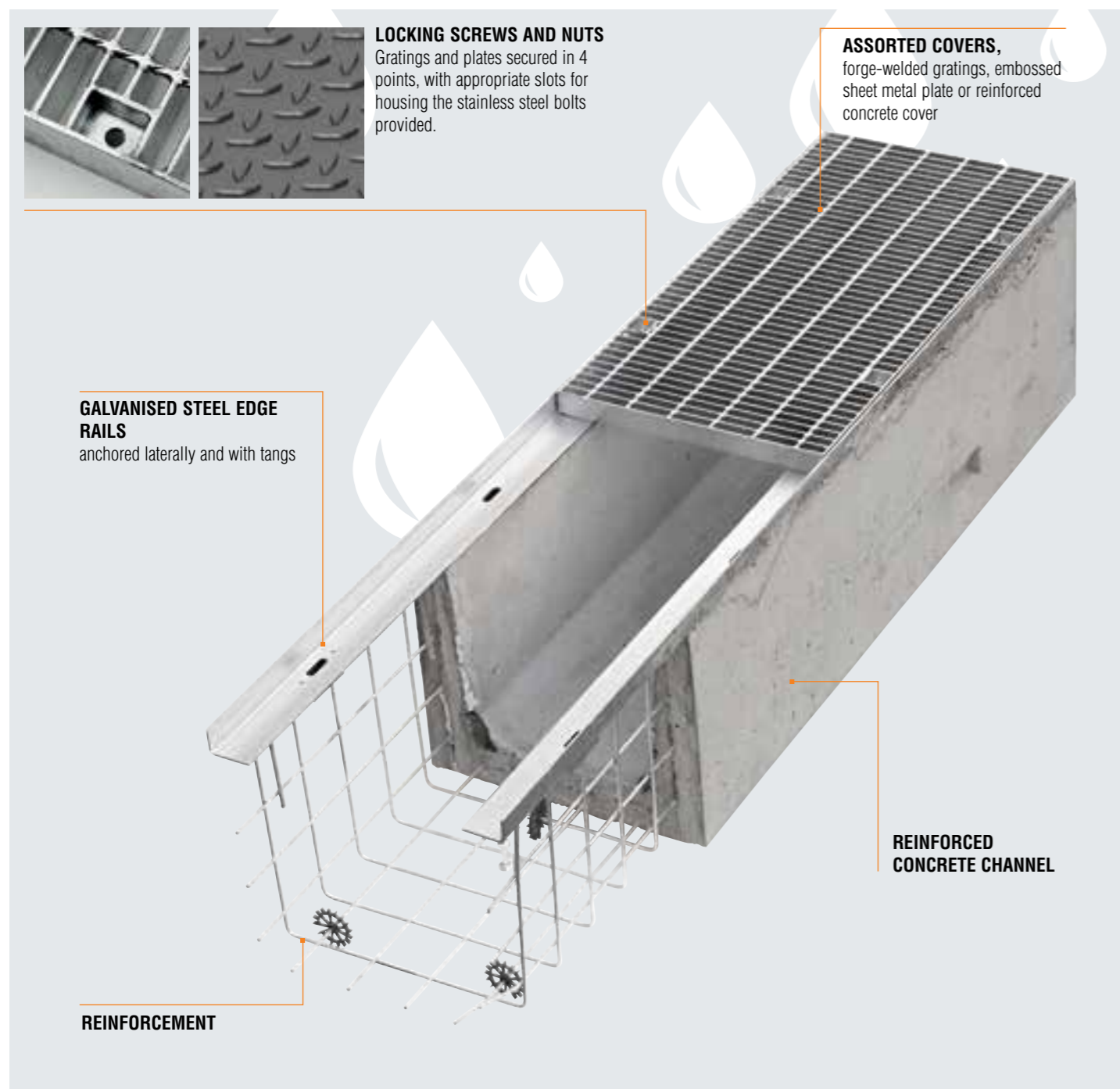

LOCKING SCREWS AND NUTS
Gratings and plates secured in 4 points, with appropriate slots for housing the stainless steel bolts provided.

ASSORTED COVERS,
forge-welded gratings, embossed sheet metal plate or reinforced concrete cover

GALVANISED STEEL EDGE RAILS
anchored laterally and with tangs

REINFORCED CONCRETE CHANNEL

REINFORCEMENT

ACCESSORIES FOR C SERIES CHANNELS



All C series channels are equipped with lifting pins located in 3 points of the channel.
N.B.: the hook is not provided.

REINFORCED CONCRETE CHANNELS

C 500 SERIES

Grating width 500 mm

Reinforced concrete channel with galvanised edge rails complying with the UNI EN 1433 standard.
The channels are sold exclusively in complete pallets and together with the gratings.



C 500 Series channel dimensions

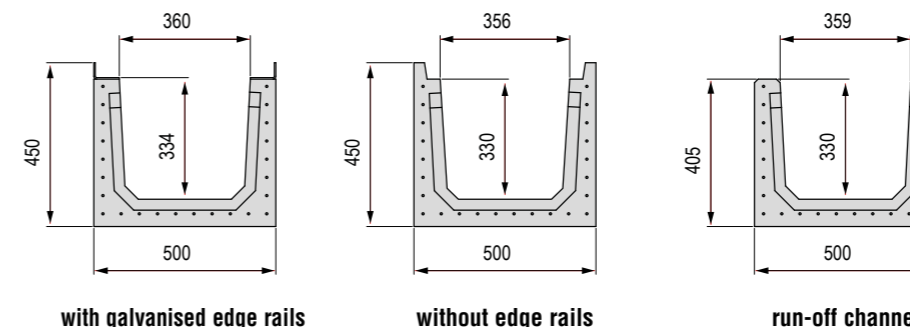

Available gratings *N.B.: the concrete cover is available only on request*

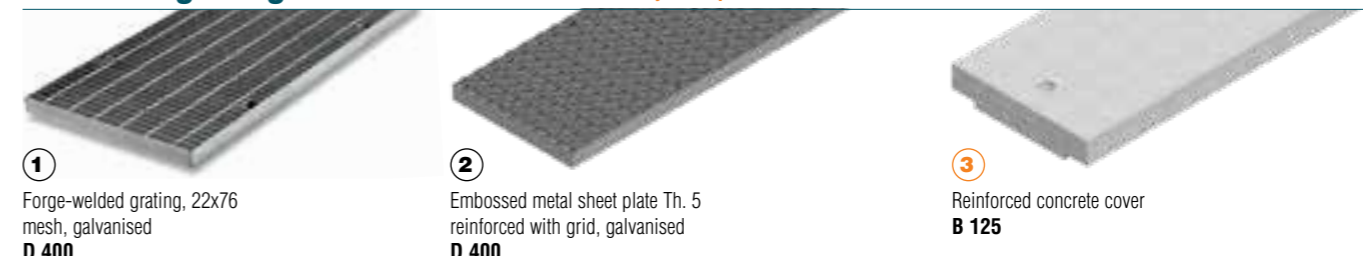

Grating L mm	Code	Grating	Description of the gratings complete with accessories for C 500 channel	Weight kg	Load class
1,000	4W00G	①	Forge-welded galvanised grating 40x4 22x76 complete with stainless steel nuts and bolts	31.90	D 400
	4W00P	②	Embossed metal sheet plate Th. 5 reinforced with galvanised grid, complete with stainless steel nuts and bolts	35.50	
	4WA0C	③	Solid reinforced concrete cover only for water run-off channel	75.00	B 125

C 500 Series channel without grating

Channel L mm	Code	Description	Water passage mm	Run-off section cm ²	Weight kg	Pieces pallet
2,000	4W01S	Reinforced concrete channel with galvanised edge rails (combine with 2 gratings or plates L=1,000 mm)	360	1099	478	4
	4WN1S	Reinforced concrete channel without galvanised edge rails (combine with 2 gratings or plates L=1,000 mm)	356	1099	488	4
	4WA1S	Reinforced concrete water run-off channel (combine with 2 reinforced concrete covers L=1,000 mm)	359	1099	468	4
1,000	4W00S	Reinforced concrete channel with galvanised edge rails	360	1099	239	6
	4WN0S	Reinforced concrete channel without galvanised edge rails	356	1099	244	6
	4WA0S	Reinforced concrete water run-off channel	359	1099	234	6

ADDITIONAL PROCESSING ON REQUEST

Code	Accessories	Weight kg
	Channel bottom drilling Ø202 mm	

REINFORCED CONCRETE CHANNELS C 600 SERIES

Grating width 600 mm

Reinforced concrete channel with galvanised edge rails complying with the UNI EN 1433 standard. The channels are sold exclusively in complete pallets and together with the gratings.



C 600 Series channel dimensions

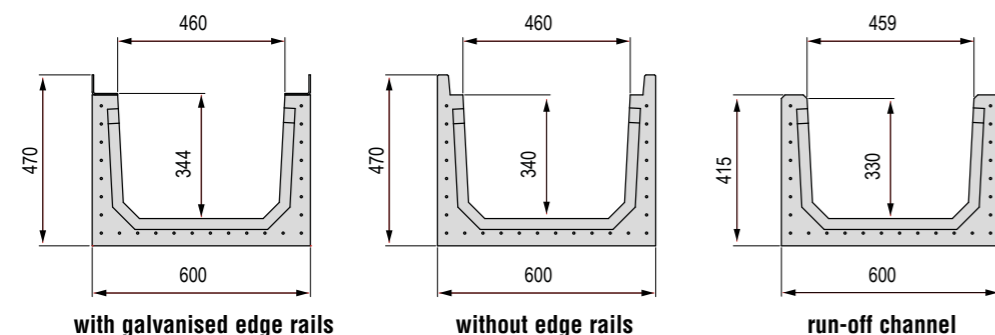

Available gratings N.B.: the concrete cover is available only on request



Grating L mm	Code	Grating	Description of the gratings complete with accessories for C 600 channel	Weight kg	Load class
1,000	4X00G	①	Forge-welded galvanised grating 50x4 22x76 complete with stainless steel nuts and bolts	50.30	D 400
	4X00P	②	Embossed metal sheet plate Th. 5 reinforced with galvanised grid, complete with stainless steel nuts and bolts	54.00	
	4XA06	③	Solid reinforced concrete cover only for water run-off channel	135.66	B 125

C 600 Series channel without grating

Channel L mm	Code	Description	Water passage mm	Run-off section cm ²	Weight kg	Pieces pallet
2,000	4X01S	Reinforced concrete channel with galvanised edge rails (combine with 2 gratings or plates L=1,000 mm)	460	1437	525	3
	4XN1S	Reinforced concrete channel without galvanised edge rails (combine with 2 gratings or plates L=1,000 mm)	460	1437	543	3
	4XA1S	Reinforced concrete water run-off channel (combine with 2 reinforced concrete covers L=1,000 mm)	459	1437	519	3
1,000	4X00S	Reinforced concrete channel with galvanised edge rails	460	1437	260	4
	4XN0S	Reinforced concrete channel without galvanised edge rails	460	1437	271.5	4
	4XA0S	Reinforced concrete water run-off channel	459	1437	259.5	4

ADDITIONAL PROCESSING ON REQUEST

Code	Accessories	Weight kg
	Channel bottom drilling Ø317 mm	

REINFORCED CONCRETE CHANNELS C 700 SERIES

Grating width 700 mm

Reinforced concrete channel with galvanised edge rails complying with the UNI EN 1433 standard. The channels are sold exclusively in complete pallets and together with the gratings.



C 700 Series channel dimensions

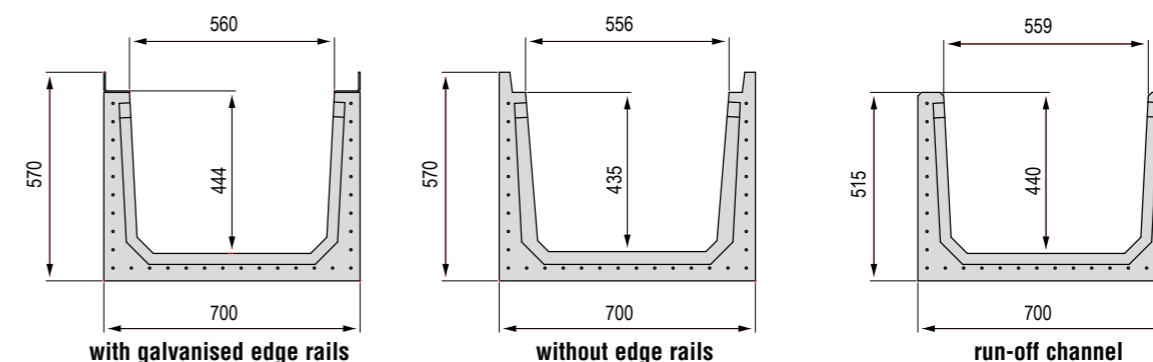

Available gratings N.B.: the concrete cover is available only on request



Grating L mm	Code	Grating	Description of the gratings complete with accessories for C 700 channel	Weight kg	Load class
1,000	4Y00G	①	Forge-welded galvanised grating 50x4 22x76 complete with stainless steel nuts and bolts	57.90	D 400
	4Y00P	②	Embossed metal sheet plate Th. 5 reinforced with galvanised grid, complete with stainless steel nuts and bolts	59.86	
	4YA06	③	Solid reinforced concrete cover only for water run-off channel	159.66	B 125

C 700 Series channel without grating

Channel L mm	Code	Description	Water passage mm	Run-off section cm ²	Weight kg	Pieces pallet
2,000	4Y01S	Reinforced concrete channel with galvanised edge rails (combine with 2 gratings or plates L=1,000 mm)	560	2256	652	2
	4YN1S	Reinforced concrete channel without galvanised edge rails (combine with 2 gratings or plates L=1,000 mm)	556	2256	660	2
	4YA1S	Reinforced concrete water run-off channel (combine with 2 reinforced concrete covers L=1,000 mm)	559	2256	646	2
1,000	4Y00S	Reinforced concrete channel with galvanised edge rails	560	2256	316	4
	4YN0S	Reinforced concrete channel without galvanised edge rails	556	2256	330	4
	4YA0S	Reinforced concrete water run-off channel	559	2256	323	4

ADDITIONAL PROCESSING ON REQUEST

Code	Accessories	Weight kg
	Channel bottom drilling Ø402 mm	

REINFORCED CONCRETE CHANNELS C 800 SERIES

Grating width 800 mm

Reinforced concrete channel with galvanised edge rails complying with the UNI EN 1433 standard. The channels are sold exclusively in complete pallets and together with the gratings.

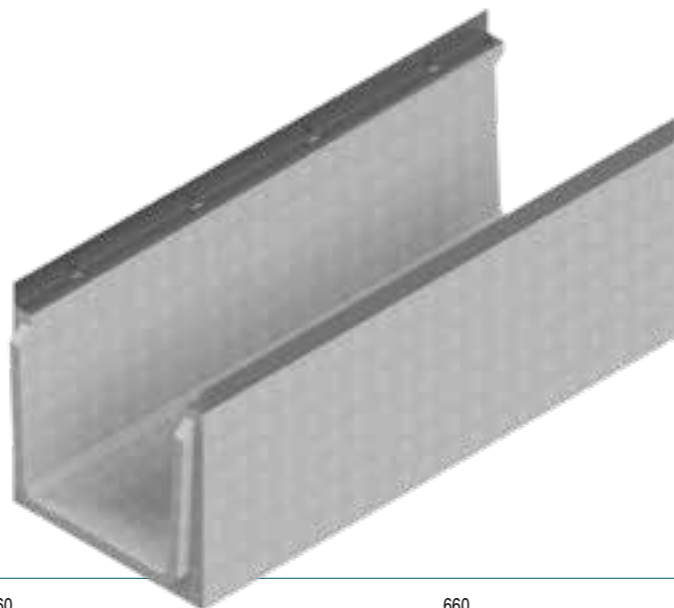

C 800 Series channel dimensions

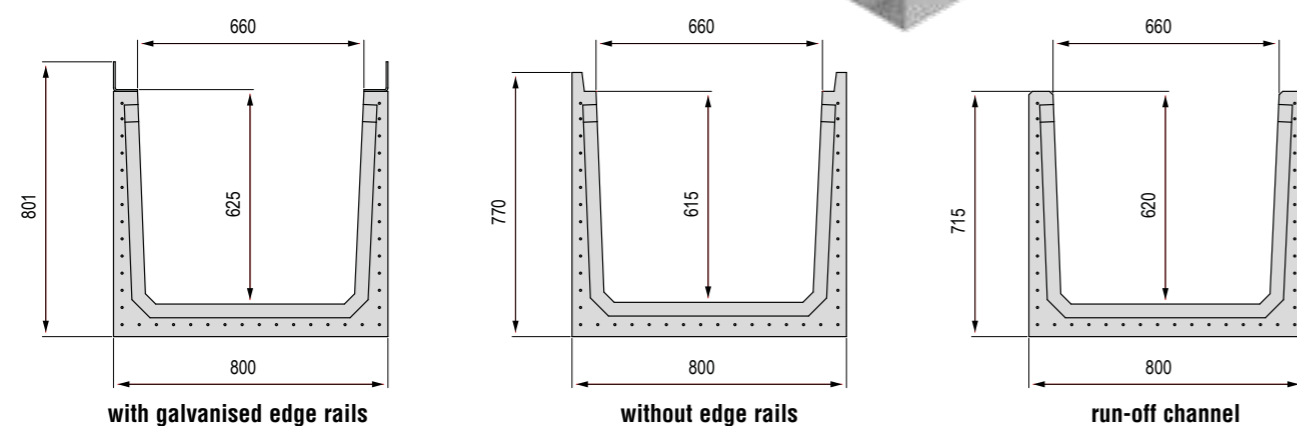

Available gratings N.B.: the concrete cover is available only on request



Grating L mm	Code	Grating	Description of the gratings complete with accessories for C 800 channel	Weight kg	Load class
1,000	4J00G	①	Pressure-locked galvanised grating 80x4 25x66 complete with stainless steel nuts and bolts	77.30	D 400
	4J00P	②	Embossed metal sheet plate Th. 5 reinforced with galvanised grid, complete with stainless steel nuts and bolts	68.40	
	4JA0C	③	Solid reinforced concrete cover only for water run-off channel	182.47	B 125

C 800 Series channel without grating

Channel L mm	Code	Description	Water passage mm	Run-off section cm ²	Weight kg	Pieces pallet
2,000	4J01S	Reinforced concrete channel with galvanised edge rails (combine with 2 gratings or plates L=1,000 mm)	660	3773	910	loose
	4JN1S	Reinforced concrete channel without galvanised edge rails (combine with 2 gratings or plates L=1,000 mm)	660	3773	920	loose
	4JA1S	Reinforced concrete water run-off channel (combine with 2 reinforced concrete covers L=1,000 mm)	660	3773	738	loose
1,000	4J00S	Reinforced concrete channel with galvanised edge rails	660	3773	372	loose
	4JN0S	Reinforced concrete channel without galvanised edge rails	660	3773	377	loose
	4JA0S	Reinforced concrete water run-off channel	660	3773	369	loose

ADDITIONAL PROCESSING ON REQUEST

Code	Accessories	Weight kg
	Channel bottom drilling Ø402 mm	



XL

SERIES

REINFORCED CONCRETE CHANNELS

REINFORCED CONCRETE CHANNELS

Channels specially designed for draining large surfaces such as airports, logistics centres, harbours, etc. The XL range is made of extremely high quality concrete and inert materials vibrated into metal formwork to improve concrete performance during the curing phase (crucial for obtaining concrete with high compressive strength).

The inner reinforcement, the thickness of the structure – a single element measuring 5 linear metres available in 4 different heights – the quality of the ductile iron and of the buried frames secured to the reinforcement, certify the product as a Class F900 self-supporting Type I element that has passed all the tests required by the UNI EN 1433 standard.



• XL 410

LOAD CLASSES

In accordance with the UNI EN 1433 standard



F 900

REINFORCED CONCRETE CHANNELS

XL SERIES

TECHNICAL CHARACTERISTICS



REINFORCED CONCRETE CHANNELS

XL 410 SERIES

Grating width 410 mm

Type I self-supporting reinforced concrete channel with galvanised edge rails complying with the UNI EN 1433 standard.

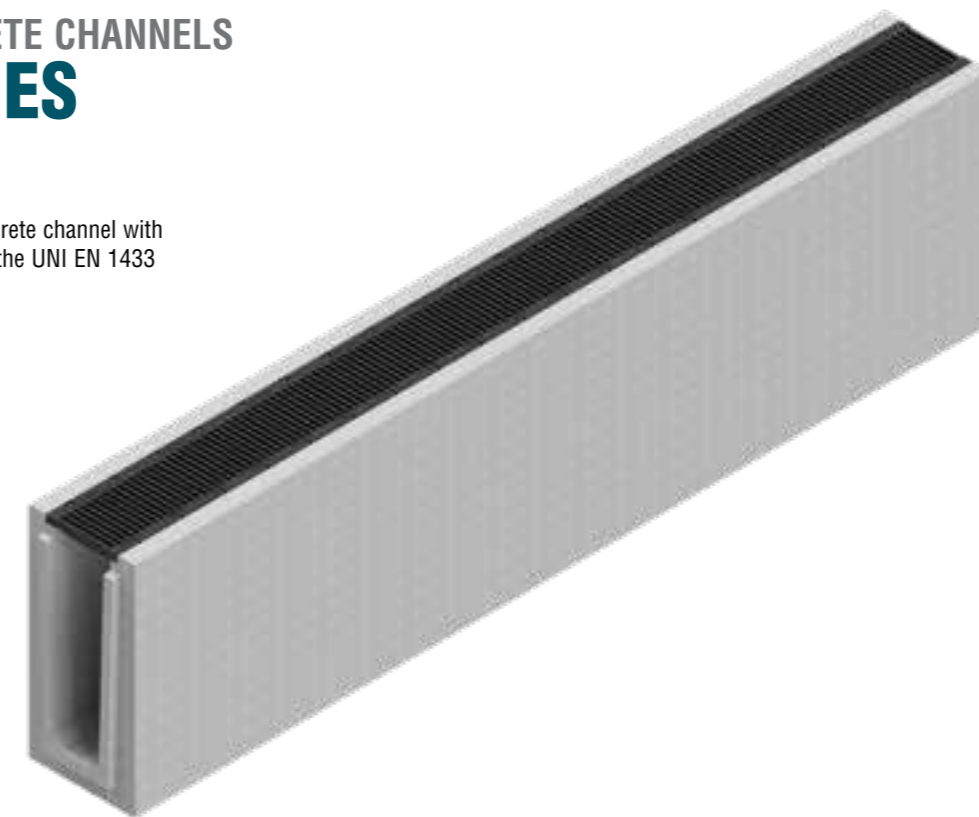

XL 410 Series channel dimensions

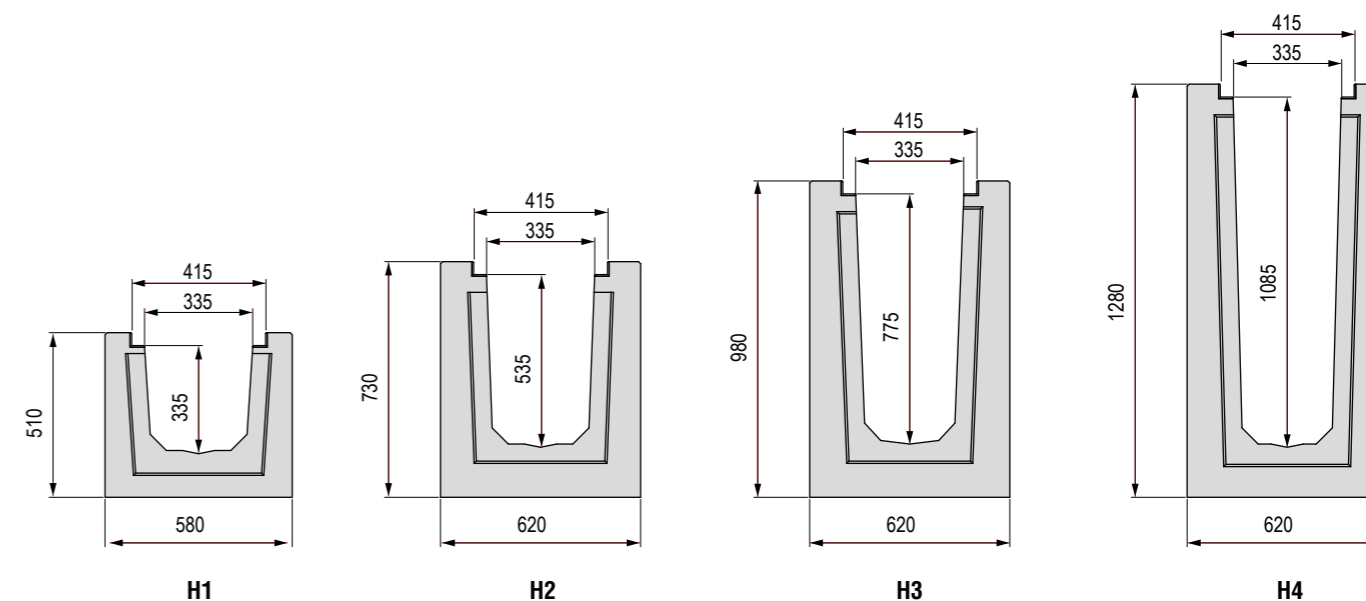

XL 410 Series channel with grating

Channel L mm	Code	Description	Water passage mm	Run-off section cm ²	Weight kg	Load class
5,000	4XLM0SGS	Type I self-supporting reinforced concrete channel with galvanised edge rails H1 complete with 10 x GJS500-7 ductile iron gratings	335	987	2590	F 900
	4XLM1SGS	Type I self-supporting reinforced concrete channel with galvanised edge rails H2 complete with 10 x GJS500-7 ductile iron gratings	335	1617	3784	
	4XLM2SGS	Type I self-supporting reinforced concrete channel with galvanised edge rails H3 complete with 10 x GJS500-7 ductile iron gratings	335	2334	4785	
	4XLM3SGS	Type I self-supporting reinforced concrete channel with galvanised edge rails H4 complete with 10 x GJS500-7 ductile iron gratings	335	3256	6000	

GRIDIRON®

CHANNELS MADE OF POLYMER CONCRETE

PAGE
104
BASE SERIES

PAGE
140
P SERIES

PAGE
168
POLY FLY SERIES

POLYMER CONCRETE
CHANNELS



GRIDIRON®
BUILD YOUR CHANGES

POLYMER CONCRETE CHANNELS

BASE SERIES

With the aid of its staff of chemical industry specialists, Gridiron has manufactured the following new polymer concrete channel ranges: Base 100 - 150 - 200 series with inlay gratings equipped with patented locking system.

A low-cost, low-range water channelling series that nonetheless meets Gridiron's safety and quality standards.



POLYMER CONCRETE CHANNELS

- BASE 100
- BASE 100 EVO
- BASE 100 WITH THIN COVER
- BASE 100 LOW
- BASE 100 LOW EVO
- BASE 100 LOW WITH THIN COVER
- BASE 150
- BASE 150 EVO
- BASE 150 WITH THIN COVER
- BASE 200
- BASE 200 EVO
- BASE 200 WITH THIN COVER

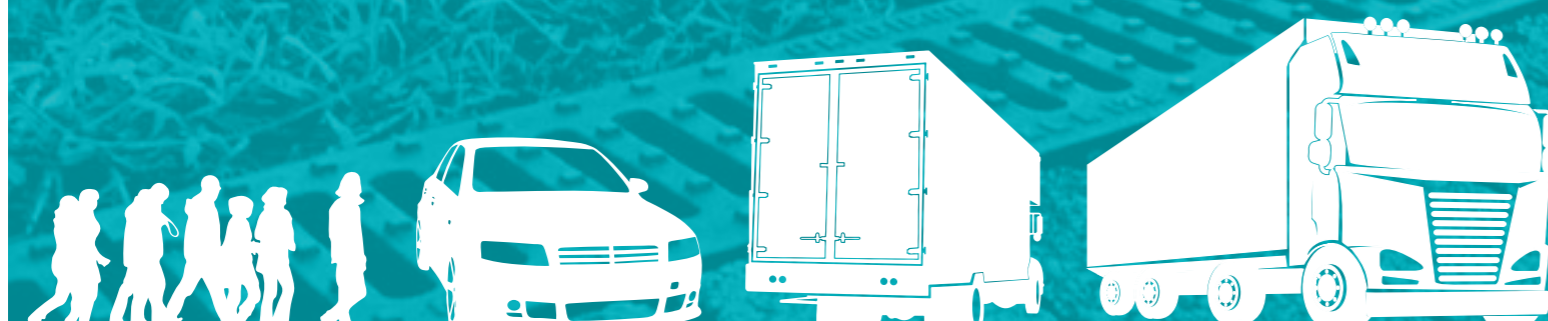

LOAD CLASSES

In accordance with the UNI EN 1433 standard



A15 • B125 • C250

POLYMER CONCRETE CHANNELS BASE SERIES

SYSTEM AND TECHNICAL CHARACTERISTICS

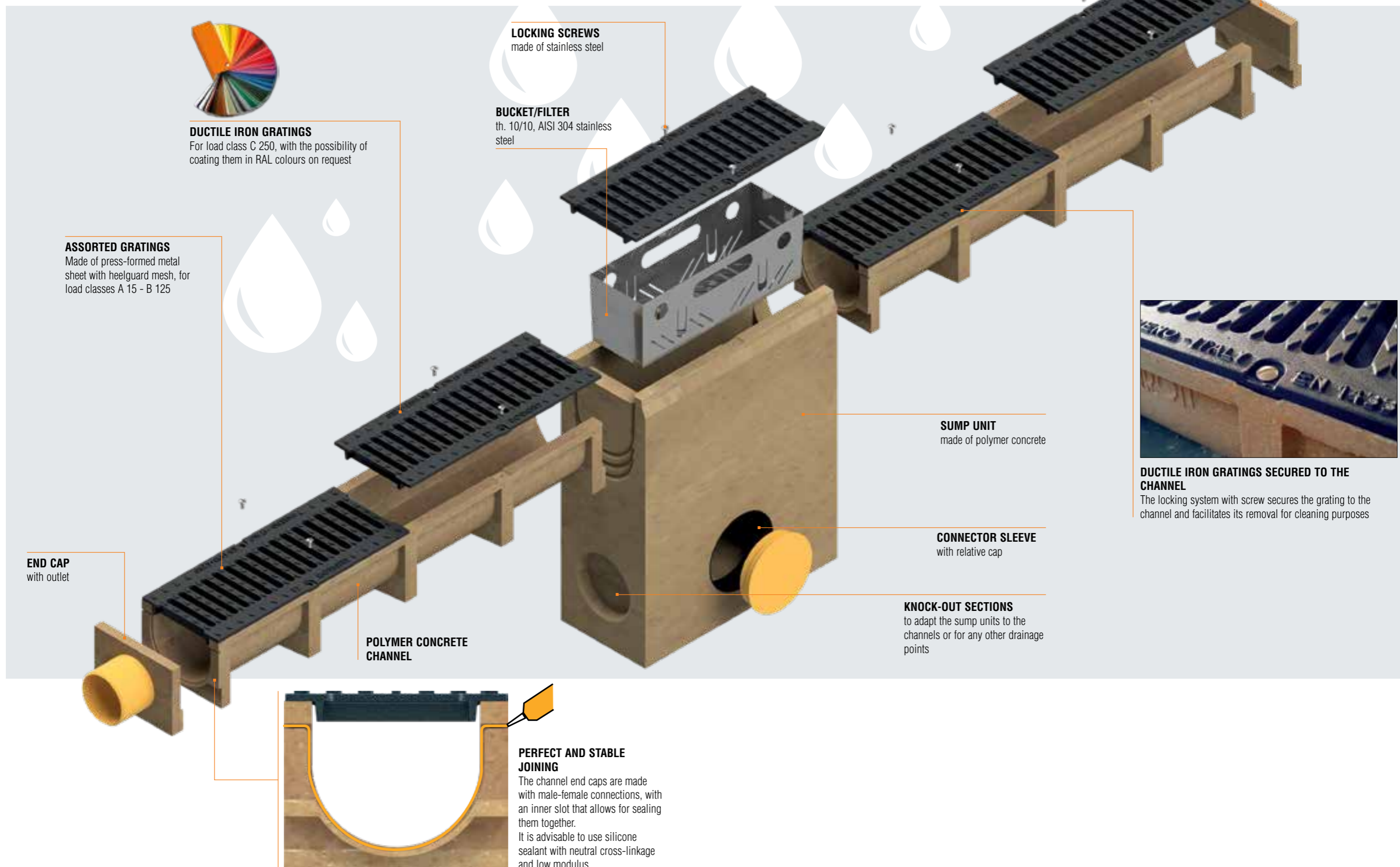

POLYMER CONCRETE CHANNELS BASE 100

Grating width 127 mm

Polymer concrete channel complying with the UNI EN 1433 standard. The channels are sold exclusively in complete pallets and together with the gratings.

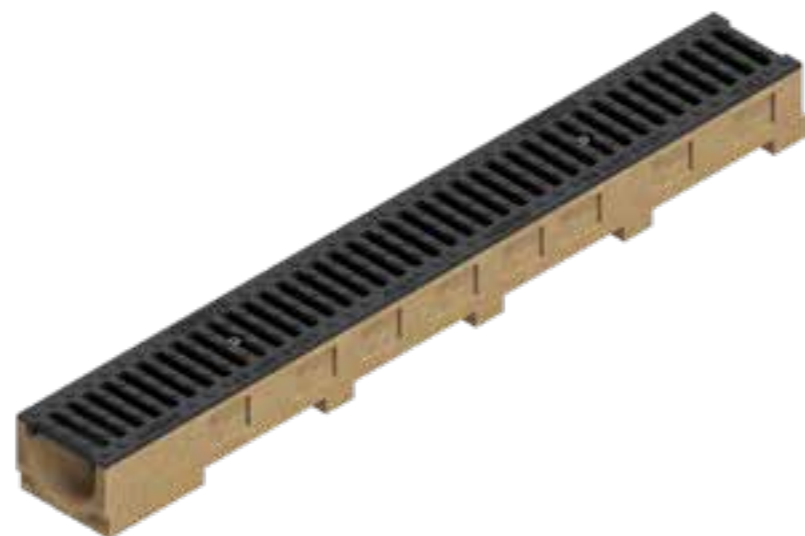

Base 100 channel dimensions

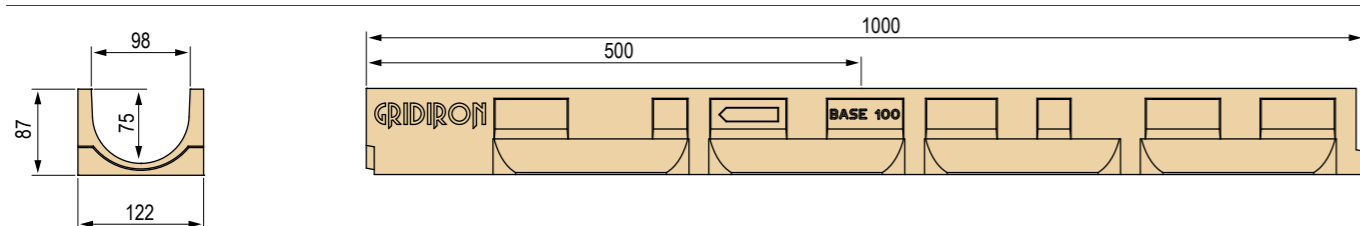

Available gratings



Base 100 channel complete with grating - Length 1,000 / 500 mm

Channel L mm	Code	Grating	Description of the channel assembled with the grating complete with accessories	Weight kg	Load class
1,000	4505SLA	①	Channel complete with self-locking inlay grating made of press-formed metal sheet, galvanised, 8 mm slots, Th. 10/10	8.90	A 15
	4505SL8	②	Channel complete with self-locking inlay grating made of press-formed metal sheet, galvanised, 6 mm heelguard slots, Th. 10/10	9.02	
	4505SGIA	③	Channel complete with self-locking inlay grating made of AISI 304 stainless steel press-formed metal sheet, 8 mm slots, Th. 8/10	9.00	
	4505SAA	④	Channel complete with pressure-locked heelguard inlay grating 20x2-10x2 33x11, hot-dip galvanised	10.95	B 125
	4505SGGB	⑤	Channel complete with 2 x GJS500-7 ductile iron inlay gratings	12.70	
	4505SGSB	⑥	Channel complete with 2 x GJS500-7 ductile iron inlay gratings with 6 mm slots	15.16	
500	4506SLA	①	Channel complete with self-locking inlay grating made of press-formed metal sheet, galvanised, 8 mm slots, Th. 10/10	4.45	A 15
	4506SL8	②	Channel complete with self-locking inlay grating made of press-formed metal sheet, galvanised, 6 mm heelguard slots, Th. 10/10	4.51	
	4506SGIA	③	Channel complete with self-locking inlay grating made of AISI 304 stainless steel press-formed metal sheet, 8 mm slots, Th. 8/10	4.50	
	4506SAA	④	Channel complete with pressure-locked heelguard inlay grating 20x2-10x2 33x11, hot-dip galvanised	5.48	B 125
	4506SGGB	⑤	Channel complete with GJS500-7 ductile iron inlay grating	6.35	
	4506SGSB	⑥	Channel complete with GJS500-7 ductile iron inlay grating with 6 mm slots	7.58	

Base 100 accessories

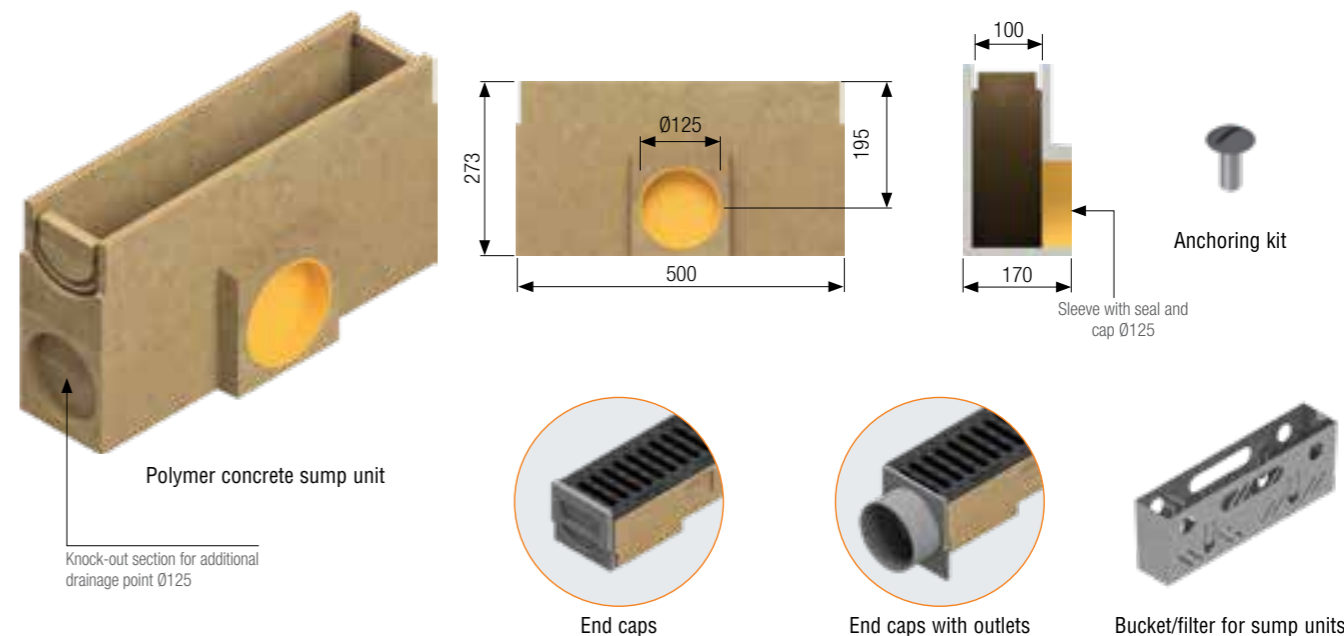

Base 100 polymer concrete sump unit complete with grating - Length 500 mm

Sump unit L mm	Code	Grating	Description of the sump unit assembled with the grating complete with accessories	Weight kg	Load class
500	4505PLA	①	Sump unit complete with self-locking inlay grating made of press-formed metal sheet, galvanised, 8 mm slots, Th. 10/10	13.22	A 15
	4505PL8	②	Sump unit complete with self-locking inlay grating made of press-formed metal sheet, galvanised, 6 mm heelguard slots, Th. 10/10	13.26	
	4505PGIA	③	Sump unit complete with self-locking inlay grating made of AISI 304 stainless steel press-formed metal sheet, 8 mm slots, Th. 8/10	13.10	
	4505PAA	④	Sump unit complete with pressure-locked heelguard inlay grating 20x2-10x2 33x11, hot-dip galvanised	14.05	B 125
	4505PGGB	⑤	Sump unit complete with GJS500-7 ductile iron inlay grating	14.95	
	4505PGSB	⑥	Sump unit complete with GJS500-7 ductile iron inlay grating with 6 mm heelguard slots	16.18	

Base 100 polymer concrete sump unit without grating and accessories

Code	Description	Weight kg
4505P	Polymer concrete sump unit L 500 mm	12.50
4505V	Removable filter bucket for Base 100 channel	0.92
4505T	End cap for channel	0.09
4505R	End cap with outlet for channel Ø110 mm	0.12
4505B	Anchor for Base 100 channel for ductile iron grating (2 x 1m)	0.91

Base 100 channel without grating - Length 1,000 / 500 mm

Channel L mm	Code	Description	Water passage mm	Run-off section cm ²	Weight kg	Pieces pallet
1,000	4505S	Polymer concrete channel	100	62	7.8	96
500	4506S	Polymer concrete channel	100	62	4.5	loose

POLYMER CONCRETE CHANNELS **BASE 100 EVO (with edge rail)**

Grating width 127 mm

Polymer concrete channel with galvanised protective edge rail complying with the UNI EN 1433 standard. The channels are sold exclusively in complete pallets and together with the gratings.

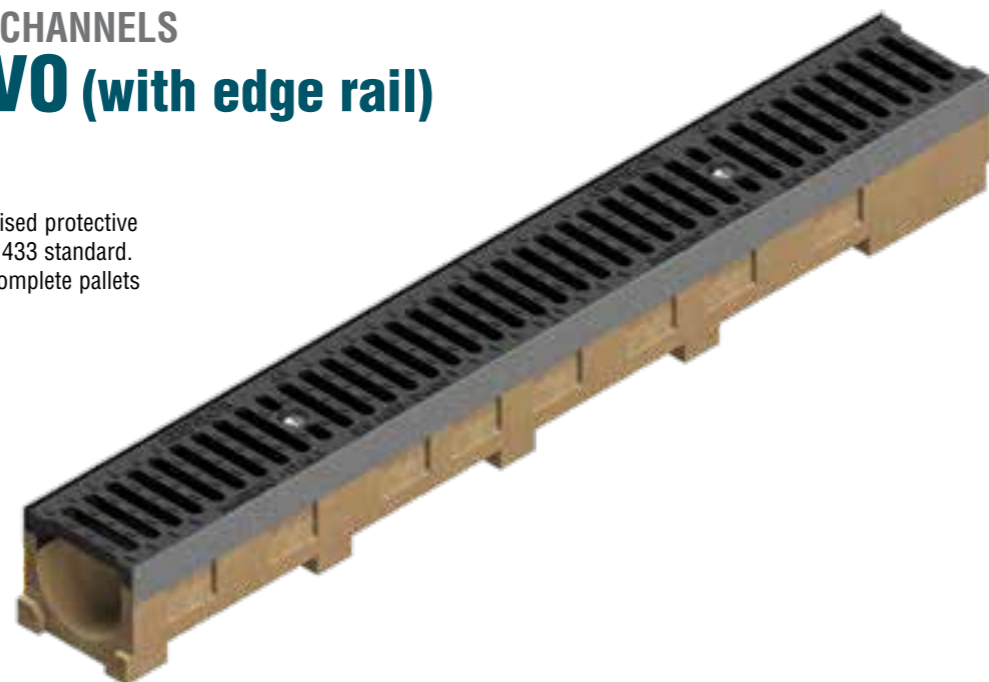

Base 100 EVO channel dimensions

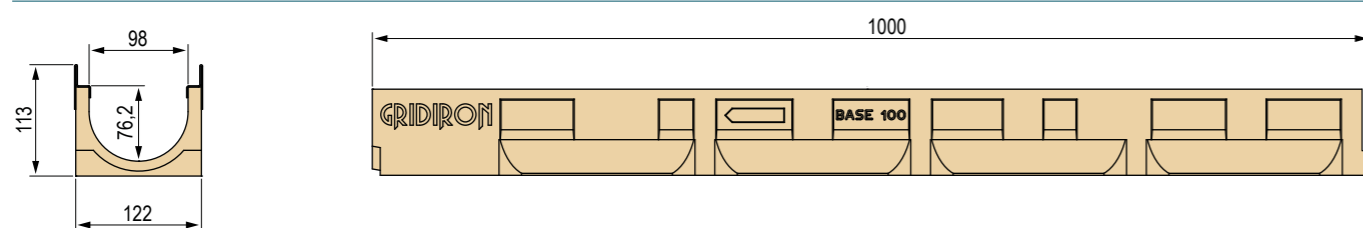

Available gratings



① Pressure-locked grating, 33x11 heelguard mesh, galvanised
B 125

② Pressure-locked grating, 33x33 mesh, galvanised
B 125

③ Pressure-locked grating, 55x11 heelguard mesh, galvanised
B 125

④ Ductile iron grating
C 250

Base 100 EVO channel complete with grating - Length 1,000 / 500 mm

Channel L mm	Code	Grating	Description of the channel assembled with the grating complete with accessories	Weight kg	Load class
1,000	4505SPGA	①	EVO series channel complete with hot-dip galvanised 20x2-10x2 33x11 heelguard pressure-locked grating	11.93	B 125
	4505SPGP	②	EVO series channel complete with hot-dip galvanised 20x2-10x2 33x33 pressure-locked grating	10.98	
	4505SPGPB	③	EVO series channel complete with hot-dip galvanised 20x2-10x2 55x11 heelguard pressure-locked grating	11.45	
	4505SPG	④	EVO series channel complete with 2 x GJS500-7 ductile iron gratings	16.02	C 250

Base 100 EVO accessories

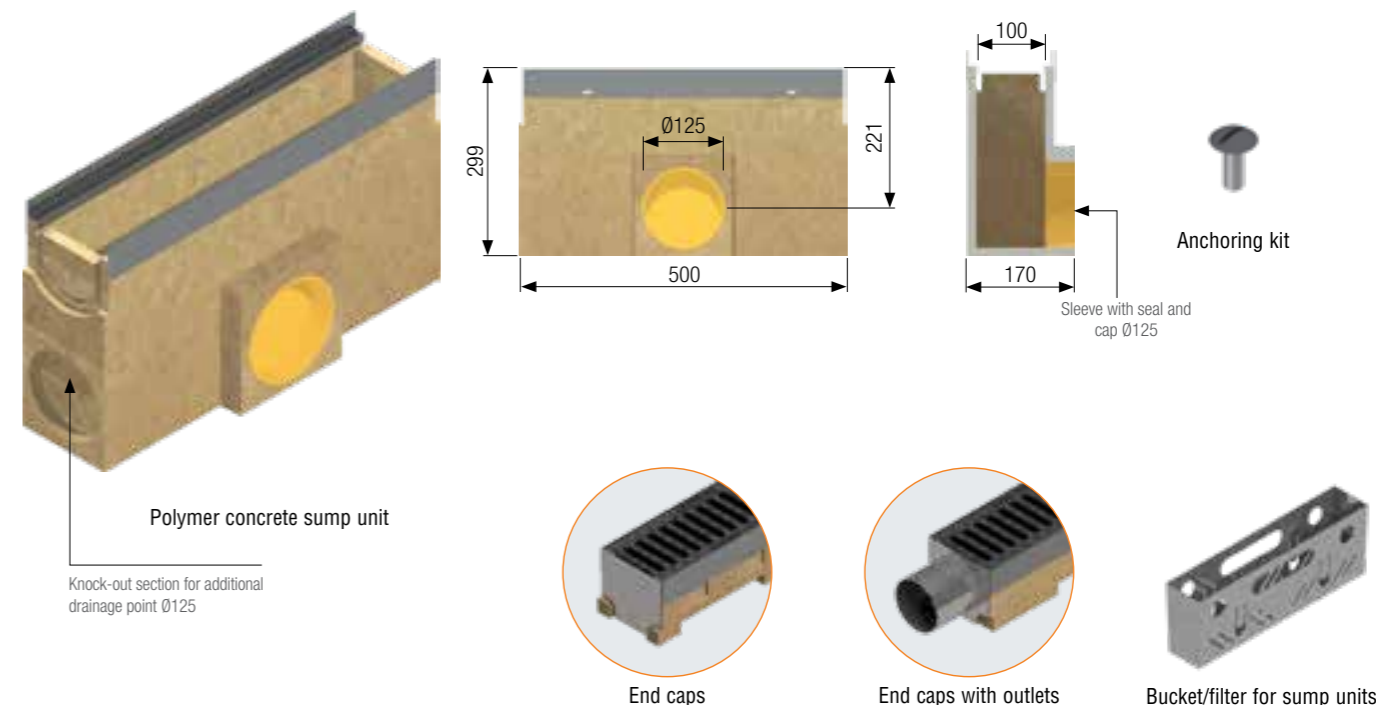

Base 100 EVO polymer concrete sump unit complete with grating - Length 500 mm

Sump unit L mm	Code	Grating	Description of the sump unit assembled with the grating complete with accessories	Weight kg	Load class
500	4505PPGA	①	EVO series sump unit complete with hot-dip galvanised 20x2-10x2 33x11 heelguard pressure-locked grating	14.41	B 125
	4505PPGP	②	EVO series sump unit complete with hot-dip galvanised 20x2-10x2 33x33 pressure-locked grating	13.81	
	4505PPGPB	③	EVO series sump unit complete with hot-dip galvanised 20x2-10x2 55x11 heelguard pressure-locked grating	13.93	
	4505PPG	④	EVO series sump unit complete with GJS500-7 ductile iron grating	16.29	C 250

Base 100 EVO polymer concrete sump unit without grating and accessories

Code	Description	Weight kg
4505PP	EVO series polymer concrete sump unit L 500 mm	12.61
4505V	Removable filter bucket for Base 100 channel	0.92
4505PTI	End cap for channel	0.09
4505PRI	End cap with outlet for channel Ø110 mm	0.12
4351B	Anchor for hot-dip galvanised 20x2-10x2 33x33 pressure-locked grating (2 x 1m)	0.09
4351BA	Anchor for hot-dip galvanised 20x2-10x2 55x11 and 33x11 heelguard pressure-locked grating	0.09
4302B	Anchor for GJS500-7 ductile iron grating (2 x 1m)	0.09

Base 100 EVO channel without grating - Length 1,000

Channel L mm	Code	Description	Water passage mm	Run-off section cm ²	Weight kg	Pieces pallet
1,000	4505SP	EVO series polymer concrete channel with galvanised edge rails	100	62	9.55	64

POLYMER CONCRETE CHANNELS

BASE 100 WITH THIN COVER

CENTRAL SLOT

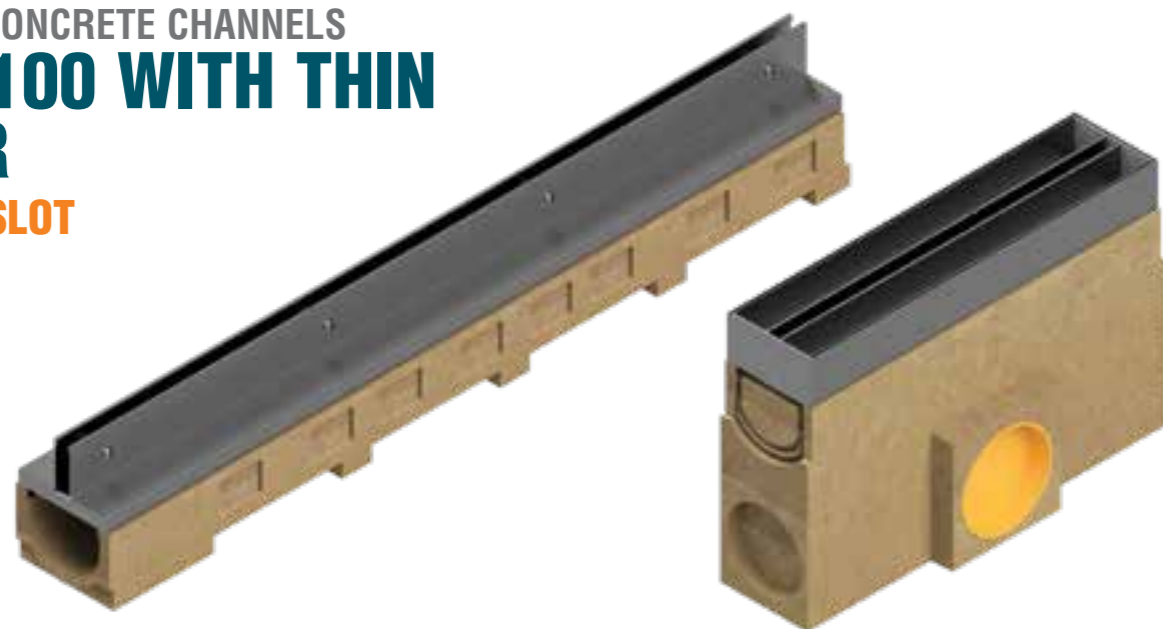

Base 100 channel dimensions

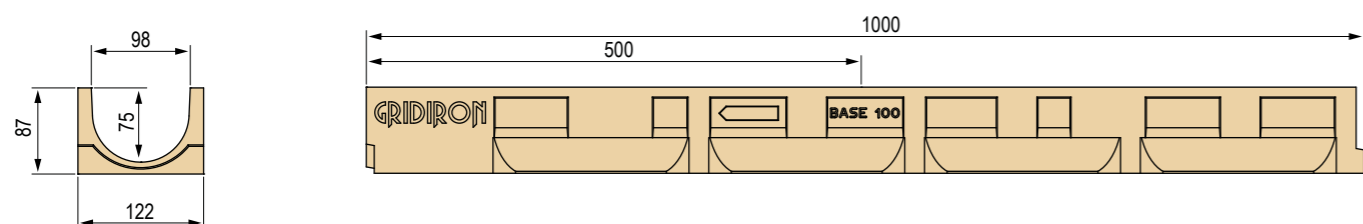

Available Thin covers

N.B.: available on request with 10 mm heelguard slot and in AISI 316 stainless steel

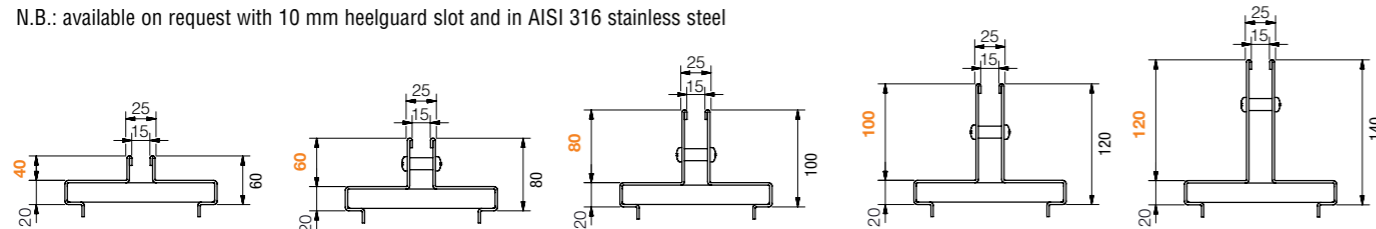

Base 100 channel without grating - Length 1,000 / 500 mm

Channel L mm	Code	Description	Water passage mm	Run-off section cm ²	Weight kg	Pieces pallet
1,000	4505S	Polymer concrete channel	100	62	7.8	loose
500	4506S	Polymer concrete channel	100	62	4.5	loose

Base 100 polymer concrete sump unit without grating

Sump unit L mm	Code	Description	Weight kg
500	4505P	Polymer concrete sump unit L 500 mm	12.50



Thin covers with central slot - Slot width 15 mm

GALVANISED

Cover L mm	Code	Description	Slot height mm	Weight kg	Load class
1,000	4505T0	Thin central cover, hot-dip galvanised, Th. 20/10	40	4.97	C 250
	4505PT	Thin central cover, hot-dip galvanised, Th. 20/10	60	5.60	
	4505T1	Thin central cover, hot-dip galvanised, Th. 20/10	80	6.22	D 400
	4505T2	Thin central cover, hot-dip galvanised, Th. 20/10	100	6.85	
	4505T3	Thin central cover, hot-dip galvanised, Th. 20/10	120	7.48	
500	4506T0	Thin central cover, hot-dip galvanised, Th. 20/10	40	2.49	C 250
	4506T	Thin central cover, hot-dip galvanised, Th. 20/10	60	2.80	
	4506T1	Thin central cover, hot-dip galvanised, Th. 20/10	80	3.11	D 400
	4506T2	Thin central cover, hot-dip galvanised, Th. 20/10	100	3.43	
	4506T3	Thin central cover, hot-dip galvanised, Th. 20/10	120	3.74	

N.B.: the Thin cover is supplied loose

AISI 304 STAINLESS STEEL

Cover L mm	Code	Description	Slot height mm	Weight kg	Load class
1,000	4505I0	Thin central cover, AISI 304 stainless steel, Th. 20/10	40	4.97	C 250
	4505I	Thin central cover, AISI 304 stainless steel, Th. 20/10	60	5.59	
	4505I1	Thin central cover, AISI 304 stainless steel, Th. 20/10	80	6.22	D 400
	4505I2	Thin central cover, AISI 304 stainless steel, Th. 20/10	100	6.85	
	4505I3	Thin central cover, AISI 304 stainless steel, Th. 20/10	120	7.48	
500	4506I0	Thin central cover, AISI 304 stainless steel, Th. 20/10	40	2.49	C 250
	4506I	Thin central cover, AISI 304 stainless steel, Th. 20/10	60	2.80	
	4506I1	Thin central cover, AISI 304 stainless steel, Th. 20/10	80	3.11	D 400
	4506I2	Thin central cover, AISI 304 stainless steel, Th. 20/10	100	3.43	
	4506I3	Thin central cover, AISI 304 stainless steel, Th. 20/10	120	3.74	

N.B.: the Thin cover is supplied loose



Inspection buckets for Thin covers with central slot - Slot width 15 mm

GALVANISED

Bucket L mm	Code	Description	Slot height mm	Weight kg	Load class
500	4506V0	Inspection bucket for galvanised Thin central cover	40	3.98	C 250
	4506V	Inspection bucket for galvanised Thin central cover	60	4.69	
	4506V1	Inspection bucket for galvanised Thin central cover	80	5.39	D 400
	4506V2	Inspection bucket for galvanised Thin central cover	100	6.10	
	4506V3	Inspection bucket for galvanised Thin central cover	120	6.80	

N.B.: the Thin bucket is supplied loose

AISI 304 STAINLESS STEEL

Bucket L mm	Code	Description	Slot height mm	Weight kg	Load class
500	4506VI0	Inspection bucket for Thin central cover made of AISI 304 stainless steel	40	3.98	C 250
	4506VI	Inspection bucket for Thin central cover made of AISI 304 stainless steel	60	4.69	
	4506VI1	Inspection bucket for Thin central cover made of AISI 304 stainless steel	80	5.39	D 400
	4506VI2	Inspection bucket for Thin central cover made of AISI 304 stainless steel	100	6.10	
	4506VI3	Inspection bucket for Thin central cover made of AISI 304 stainless steel	120	6.80	

N.B.: the Thin bucket is supplied loose

POLYMER CONCRETE CHANNELS

BASE 100 WITH THIN COVER

SIDE SLOT

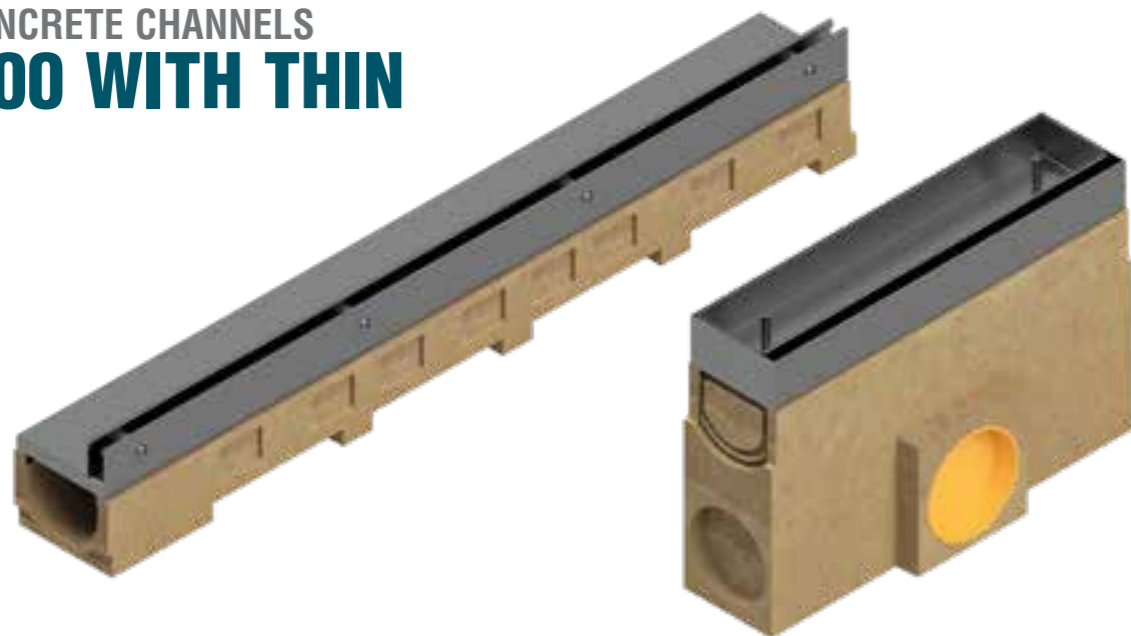

Base 100 channel dimensions

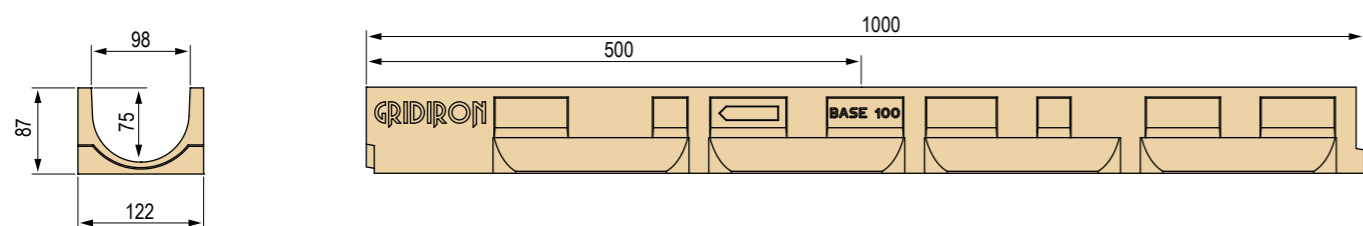

Available Thin covers

N.B.: available on request with 10 mm heelguard slot and in AISI 316 stainless steel

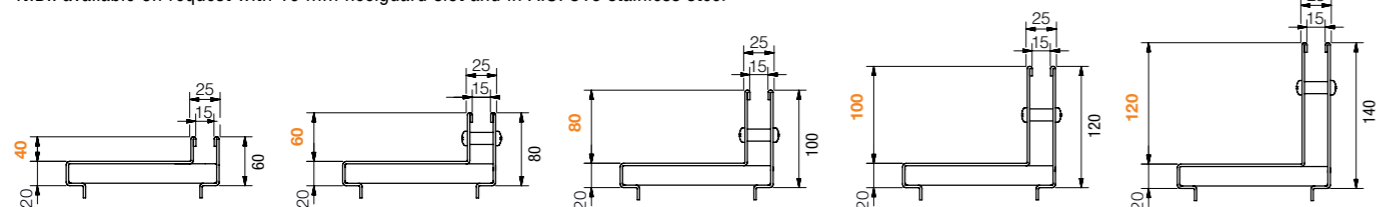

Base 100 channel without grating - Length 1,000 / 500 mm

Channel L mm	Code	Description	Water passage mm	Run-off section cm ²	Weight kg	Pieces pallet
1,000	4505S	Polymer concrete channel	100	62	7.8	loose
500	4506S	Polymer concrete channel	100	62	4.5	loose

Base 100 polymer concrete sump unit without grating

Sump unit L mm	Code	Description	Weight kg
500	4505P	Polymer concrete sump unit L 500 mm	12.50



Thin covers with side slot - Slot width 15 mm

GALVANISED

Cover L mm	Code	Description	Slot height mm	Weight kg	Load class
1,000	4505L0	Thin side cover, hot-dip galvanised, Th. 20/10	40	4.97	C 250
	4505L	Thin side cover, hot-dip galvanised, Th. 20/10	60	5.60	
	4505L1	Thin side cover, hot-dip galvanised, Th. 20/10	80	6.22	D 400
	4505L2	Thin side cover, hot-dip galvanised, Th. 20/10	100	6.85	
	4505L3	Thin side cover, hot-dip galvanised, Th. 20/10	120	7.48	
500	4506L0	Thin side cover, hot-dip galvanised, Th. 20/10	40	2.49	C 250
	4506L	Thin side cover, hot-dip galvanised, Th. 20/10	60	2.80	
	4506L1	Thin side cover, hot-dip galvanised, Th. 20/10	80	3.11	D 400
	4506L2	Thin side cover, hot-dip galvanised, Th. 20/10	100	3.43	
	4506L3	Thin side cover, hot-dip galvanised, Th. 20/10	120	3.74	

N.B.: the Thin cover is supplied loose

AISI 304 STAINLESS STEEL

Cover L mm	Code	Description	Slot height mm	Weight kg	Load class
1,000	4505IL0	Thin side cover made of AISI 304 stainless steel Th. 20/10	40	4.97	C 250
	4505IL	Thin side cover made of AISI 304 stainless steel Th. 20/10	60	5.59	
	4505IL1	Thin side cover made of AISI 304 stainless steel Th. 20/10	80	6.22	D 400
	4505IL2	Thin side cover made of AISI 304 stainless steel Th. 20/10	100	6.85	
	4505IL3	Thin side cover made of AISI 304 stainless steel Th. 20/10	120	7.48	
500	4506IL0	Thin side cover made of AISI 304 stainless steel Th. 20/10	40	2.49	C 250
	4506IL	Thin side cover made of AISI 304 stainless steel Th. 20/10	60	2.80	
	4506IL1	Thin side cover made of AISI 304 stainless steel Th. 20/10	80	3.11	D 400
	4506IL2	Thin side cover made of AISI 304 stainless steel Th. 20/10	100	3.43	
	4506IL3	Thin side cover made of AISI 304 stainless steel Th. 20/10	120	3.74	

N.B.: the Thin cover is supplied loose



Inspection buckets for Thin covers with side slot - Slot width 15 mm

GALVANISED

Bucket L mm	Code	Description	Slot height mm	Weight kg	Load class
500	4506VL0	Inspection bucket for galvanised Thin side cover	40	3.98	C 250
	4506VL	Inspection bucket for galvanised Thin side cover	60	4.69	
	4506VL1	Inspection bucket for galvanised Thin side cover	80	5.39	D 400
	4506VL2	Inspection bucket for galvanised Thin side cover	100	6.10	
	4506VL3	Inspection bucket for galvanised Thin side cover	120	6.80	

N.B.: the Thin bucket is supplied loose

AISI 304 STAINLESS STEEL

Bucket L mm	Code	Description	Slot height mm	Weight kg	Load class
500	4506VL10	Inspection bucket for Thin side cover made of AISI 304 stainless steel	40	3.98	C 250
	4506VL1	Inspection bucket for Thin side cover made of AISI 304 stainless steel	60	4.69	
	4506VL11	Inspection bucket for Thin side cover made of AISI 304 stainless steel	80	5.39	D 400
	4506VL12	Inspection bucket for Thin side cover made of AISI 304 stainless steel	100	6.10	
	4506VL13	Inspection bucket for Thin side cover made of AISI 304 stainless steel	120	6.80	

N.B.: the Thin bucket is supplied loose

POLYMER CONCRETE CHANNELS

BASE 100 LOW

Grating width 127 mm

Polymer concrete channel complying with the UNI EN 1433 standard. The channels are sold exclusively in complete pallets and together with the gratings.

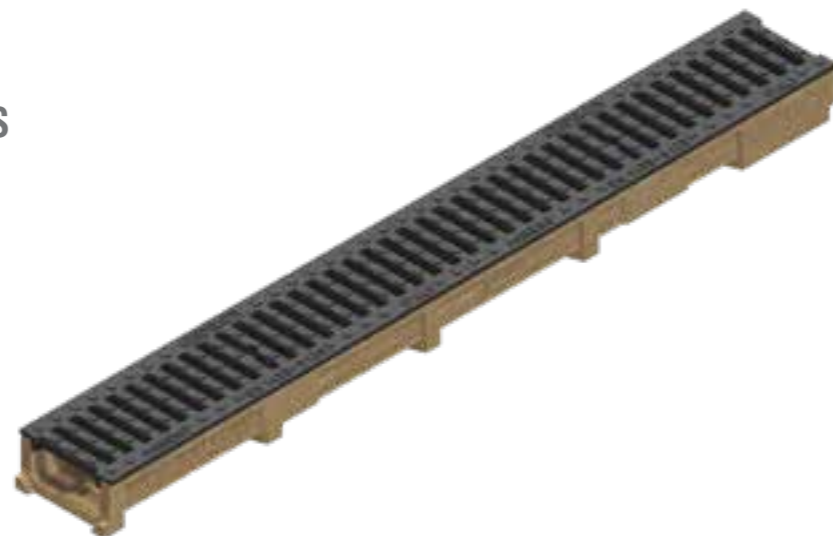

Base 100 Low channel dimensions

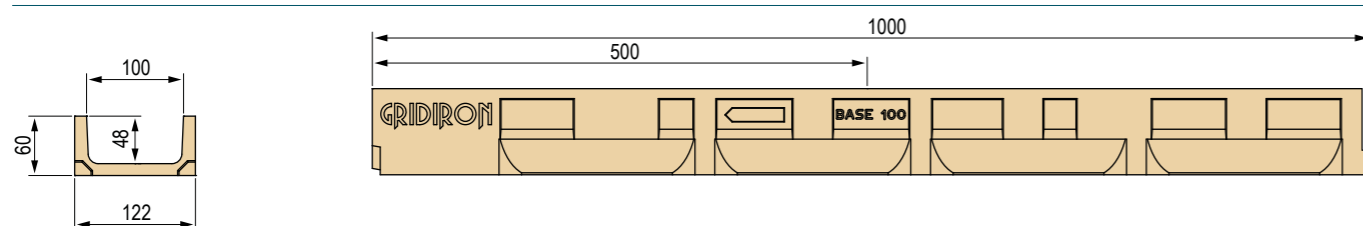

Available gratings



Base 100 Low channel complete with grating - Length 1,000 / 500 mm

Channel L mm	Code	Grating	Description of the channel assembled with the grating complete with accessories	Weight kg	Load class
1,000	45L5SLA	①	Channel complete with self-locking inlay grating made of press-formed metal sheet, galvanised, 8 mm slots, Th. 10/10	7.12	A 15
	45L5SL6	②	Channel complete with self-locking inlay grating made of press-formed metal sheet, galvanised, 6 mm heelguard slots, Th. 10/10	7.04	
	45L5SGIA	③	Channel complete with self-locking inlay grating made of AISI 304 stainless steel press-formed metal sheet, 8 mm slots, Th. 8/10	6.80	
	45L5SAA	④	Channel complete with pressure-locked heelguard inlay grating 20x2-10x2 33x11, hot-dip galvanised	8.75	B 125
	45L5SGS	⑤	Channel complete with 2 x GJS500-7 ductile iron inlay gratings	10.50	
	45L5SGA	⑥	Channel complete with 2 x GJS500-7 ductile iron inlay gratings with 6 mm heelguard slots	12.96	
500	45L6SLA	①	Channel complete with self-locking inlay grating made of press-formed metal sheet, galvanised, 8 mm slots, Th. 10/10	3.56	A 15
	45L6SL6	②	Channel complete with self-locking inlay grating made of press-formed metal sheet, galvanised, 6 mm heelguard slots, Th. 10/10	3.52	
	45L6SGIA	③	Channel complete with self-locking inlay grating made of AISI 304 stainless steel press-formed metal sheet, 8 mm slots, Th. 8/10	3.40	
	45L6SAA	④	Channel complete with pressure-locked heelguard inlay grating 20x2-10x2 33x11, hot-dip galvanised	4.38	B 125
	45L6SGS	⑤	Channel complete with GJS500-7 ductile iron inlay grating	5.25	
	45L6SGA	⑥	Channel complete with GJS500-7 ductile iron inlay grating with 6 mm heelguard slots	6.48	

Base 100 Low accessories

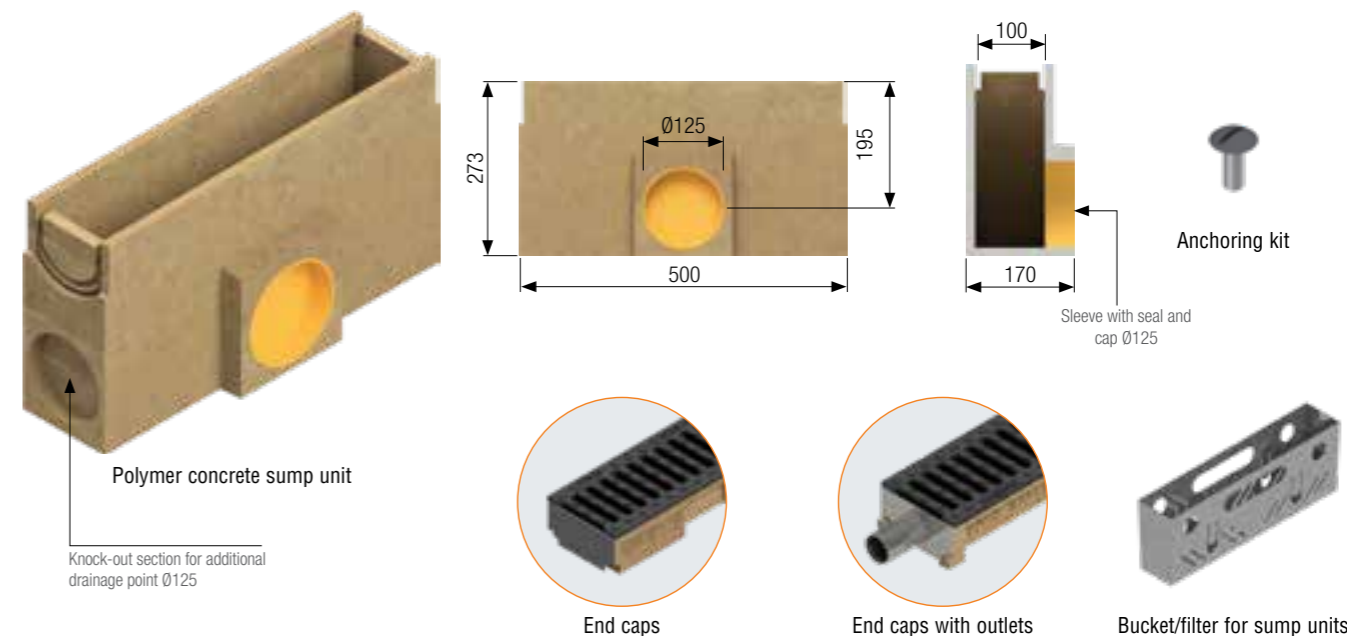

Base 100 Low polymer concrete sump unit complete with grating - Length 500 mm

Sump unit L mm	Code	Grating	Description of the sump unit assembled with the grating complete with accessories	Weight kg	Load class
500	4505PLA	①	Sump unit complete with self-locking inlay grating made of press-formed metal sheet, galvanised, 8 mm slots, Th. 10/10	13.22	A 15
	4505PL8	②	Sump unit complete with self-locking inlay grating made of press-formed metal sheet, galvanised, 6 mm heelguard slots, Th. 10/10	13.26	
	4505PGIA	③	Sump unit complete with self-locking inlay grating made of AISI 304 stainless steel press-formed metal sheet, 8 mm slots, Th. 8/10	13.10	
	4505PAA	④	Sump unit complete with pressure-locked heelguard inlay grating 20x2-10x2 33x11, hot-dip galvanised	14.08	B 125
	4505PGGB	⑤	Sump unit complete with GJS500-7 ductile iron inlay grating	14.95	
	4505PGSB	⑥	Sump unit complete with GJS500-7 ductile iron inlay grating with 6 mm heelguard slots	16.18	

Base 100 Low polymer concrete sump unit without grating and accessories

Code	Description	Weight kg
4505P	Polymer concrete sump unit L 500 mm	12.50
4505V	Removable filter bucket for Base 100 Low channel	0.92
45L5TI	End cap for channel	0.09
45L5RI	End cap with outlet for channel Ø40 mm	0.12
4505B	Anchor for Base 100 Low channel for ductile iron grating (2 x 1m)	0.91

Base 100 Low channel without grating - Length 1,000 / 500 mm

Channel L mm	Code	Description	Water passage mm	Run-off section cm ²	Weight kg	Pieces pallet
1,000	45L5S	Polymer concrete channel	100	46	4.7	104
500	45L6S	Polymer concrete channel	100	46	2.35	loose

POLYMER CONCRETE CHANNELS

BASE 100 LOW EVO (with edge rails)

Grating width 127 mm

Polymer concrete channel with galvanised protective edge rail complying with the UNI EN 1433 standard. The channels are sold exclusively in complete pallets and together with the gratings.

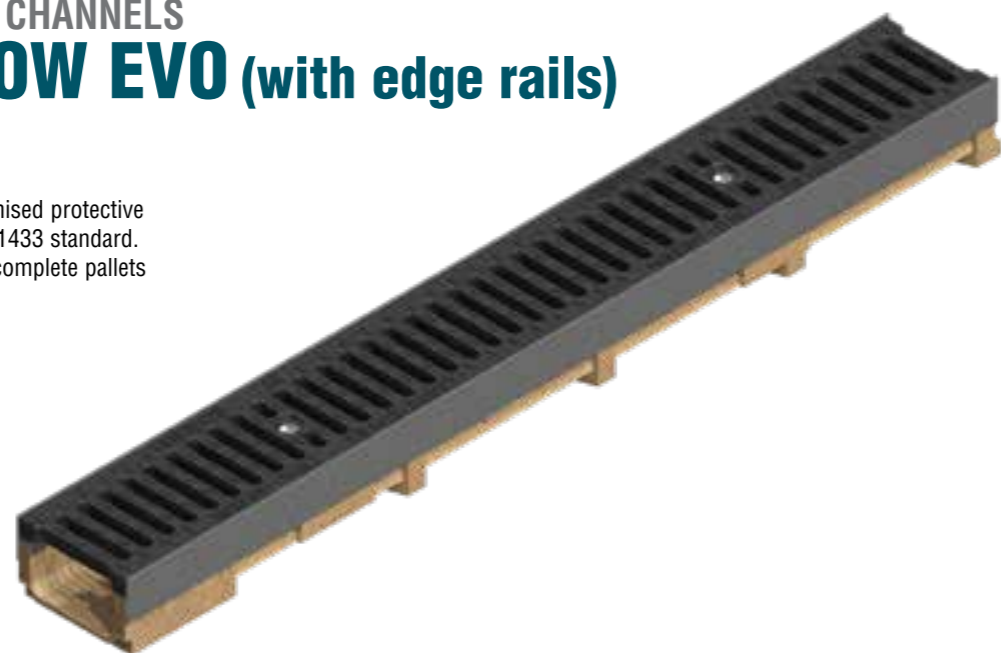

Base 100 Low EVO accessories

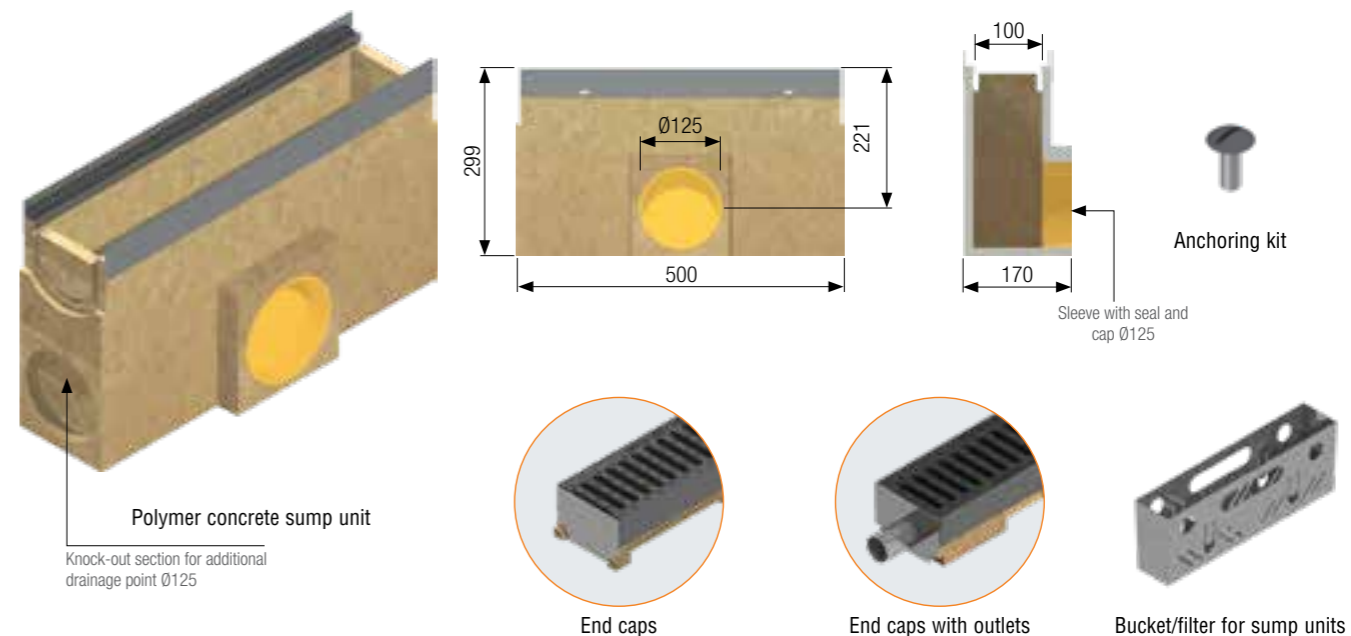

Base 100 Low EVO channel dimensions

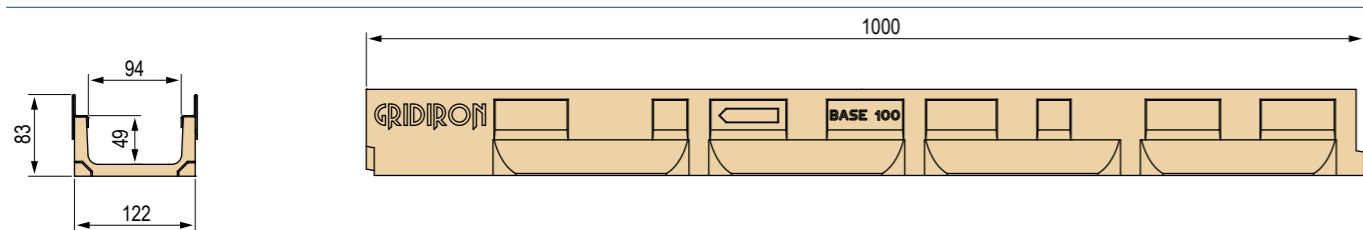

Available gratings

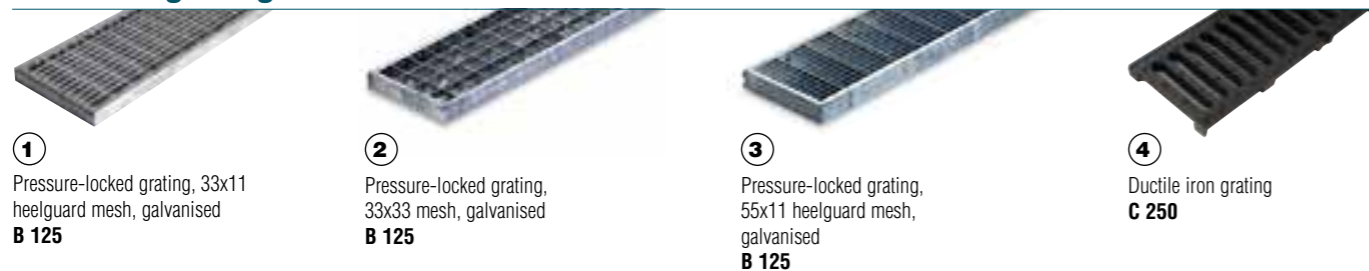

Base 100 Low EVO channel complete with grating - Length 1,000

Channel L mm	Code	Grating	Description of the channel assembled with the grating complete with accessories	Weight kg	Load class
1,000	45L5PGA	①	EVO series channel complete with hot-dip galvanised 20x2-10x2 33x11 heelguard pressure-locked grating	9.73	B 125
	45L5SGP	②	EVO series channel complete with hot-dip galvanised 20x2-10x2 33x33 pressure-locked grating	8.78	
	45L5SGPB	③	EVO series channel complete with hot-dip galvanised 20x2-10x2 55x11 heelguard pressure-locked grating	9.25	
	45L5SPS	④	EVO series channel complete with 2 x GJS500-7 ductile iron gratings	13.82	C 250

Base 100 Low EVO polymer concrete sump unit complete with grating - Length 500 mm

Sump unit L mm	Code	Grating	Description of the sump unit assembled with the grating complete with accessories	Weight kg	Load class
500	4505PPGA	①	EVO series sump unit complete with hot-dip galvanised 20x2-10x2 33x11 heelguard pressure-locked grating	14.41	B 125
	4505PPGP	②	EVO series sump unit complete with hot-dip galvanised 20x2-10x2 33x33 pressure-locked grating	13.81	
	4505PPGPB	③	EVO series sump unit complete with hot-dip galvanised 20x2-10x2 55x11 heelguard pressure-locked grating	13.93	
	4505PPG	④	EVO series sump unit complete with GJS500-7 ductile iron grating	16.29	

Base 100 Low EVO polymer concrete sump unit without grating and accessories

Code	Description	Weight kg
4505PP	Polymer concrete sump unit L 500 mm	12.61
4505V	Removable filter bucket for Base 100 channel	0.92
45L5PTI	End cap for channel	0.09
45L5PRI	End cap with outlet for channel Ø40 mm	0.12
4351B	Anchor for hot-dip galvanised 20x2-10x2 33x33 pressure-locked grating (2 x 1m)	0.09
4351BA	Anchor for hot-dip galvanised 20x2-10x2 55x11 and 33x11 heelguard pressure-locked grating	0.09
4302B	Anchor for GJS500-7 ductile iron grating (2 x 1m)	0.09

Base 100 Low EVO channel without grating - Length 1,000

Channel L mm	Code	Description	Water passage mm	Run-off section cm ²	Weight kg	Pieces pallet
1,000	45L5SP	EVO series polymer concrete channel with galvanised edge rails	100	46	8.66	104

POLYMER CONCRETE CHANNELS

BASE 100 LOW WITH THIN COVER

CENTRAL SLOT



Base 100 Low channel dimensions

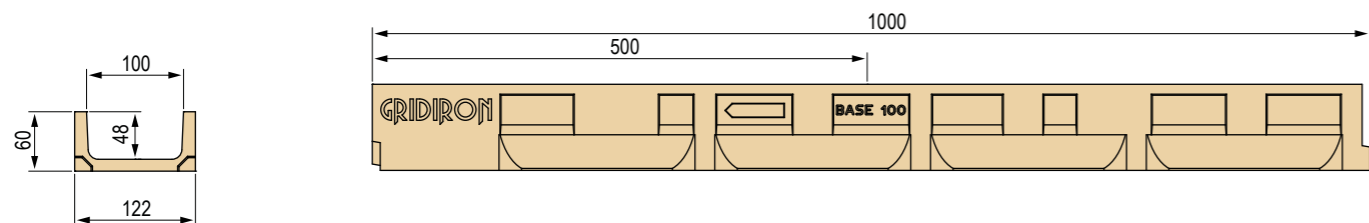

Available Thin covers

N.B.: available on request with 10 mm heelguard slot and in AISI 316 stainless steel

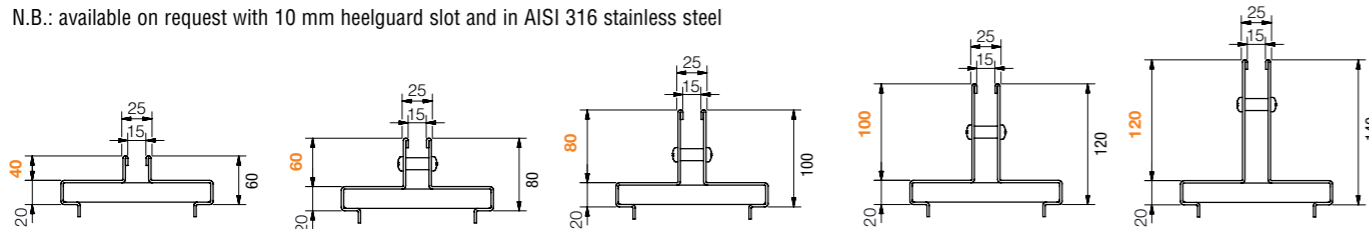

Base 100 Low channel without grating - Length 1,000 / 500 mm

Channel L mm	Code	Description	Water passage mm	Run-off section cm ²	Weight kg	Pieces pallet
1,000	45L5S	Polymer concrete channel	100	46	4.7	loose
500	45L6S	Polymer concrete channel	100	46	2.35	loose

Base 100 Low polymer concrete sump unit without grating

Sump unit L mm	Code	Description	Weight kg
500	4505P	Polymer concrete sump unit L 500 mm	12.50



Thin covers with central slot - Slot width 15 mm

GALVANISED

Cover L mm	Code	Description	Slot height mm	Weight kg	Load class
1,000	4505T0	Thin central cover, hot-dip galvanised, Th. 20/10	40	4.97	C 250
	4505PT	Thin central cover, hot-dip galvanised, Th. 20/10	60	5.60	
	4505T1	Thin central cover, hot-dip galvanised, Th. 20/10	80	6.22	D 400
	4505T2	Thin central cover, hot-dip galvanised, Th. 20/10	100	6.85	
	4505T3	Thin central cover, hot-dip galvanised, Th. 20/10	120	7.48	
500	4506T0	Thin central cover, hot-dip galvanised, Th. 20/10	40	2.49	C 250
	4506T	Thin central cover, hot-dip galvanised, Th. 20/10	60	2.80	
	4506T1	Thin central cover, hot-dip galvanised, Th. 20/10	80	3.11	D 400
	4506T2	Thin central cover, hot-dip galvanised, Th. 20/10	100	3.43	
	4506T3	Thin central cover, hot-dip galvanised, Th. 20/10	120	3.74	

N.B.: the Thin cover is supplied loose

AISI 304 STAINLESS STEEL

Cover L mm	Code	Description	Slot height mm	Weight kg	Load class
1,000	4505I0	Thin central cover, AISI 304 stainless steel, Th. 20/10	40	4.97	C 250
	4505I	Thin central cover, AISI 304 stainless steel, Th. 20/10	60	5.59	
	4505I1	Thin central cover, AISI 304 stainless steel, Th. 20/10	80	6.22	D 400
	4505I2	Thin central cover, AISI 304 stainless steel, Th. 20/10	100	6.85	
	4505I3	Thin central cover, AISI 304 stainless steel, Th. 20/10	120	7.48	
500	4506I0	Thin central cover, AISI 304 stainless steel, Th. 20/10	40	2.49	C 250
	4506I	Thin central cover, AISI 304 stainless steel, Th. 20/10	60	2.80	
	4506I1	Thin central cover, AISI 304 stainless steel, Th. 20/10	80	3.11	D 400
	4506I2	Thin central cover, AISI 304 stainless steel, Th. 20/10	100	3.43	
	4506I3	Thin central cover, AISI 304 stainless steel, Th. 20/10	120	3.74	

N.B.: the Thin cover is supplied loose



Inspection buckets for Thin covers with central slot - Slot width 15 mm

GALVANISED

Bucket L mm	Code	Description	Slot height mm	Weight kg	Load class
500	4506V0	Inspection bucket for galvanised Thin central cover	40	3.98	C 250
	4506V	Inspection bucket for galvanised Thin central cover	60	4.69	
	4506V1	Inspection bucket for galvanised Thin central cover	80	5.39	D 400
	4506V2	Inspection bucket for galvanised Thin central cover	100	6.10	
	4506V3	Inspection bucket for galvanised Thin central cover	120	6.80	

N.B.: the Thin bucket is supplied loose

AISI 304 STAINLESS STEEL

Bucket L mm	Code	Description	Slot height mm	Weight kg	Load class
500	4506VI0	Inspection bucket for Thin central cover made of AISI 304 stainless steel	40	3.98	C 250
	4506VI	Inspection bucket for Thin central cover made of AISI 304 stainless steel	60	4.69	
	4506VI1	Inspection bucket for Thin central cover made of AISI 304 stainless steel	80	5.39	D 400
	4506VI2	Inspection bucket for Thin central cover made of AISI 304 stainless steel	100	6.10	
	4506VI3	Inspection bucket for Thin central cover made of AISI 304 stainless steel	120	6.80	

N.B.: the Thin bucket is supplied loose

POLYMER CONCRETE CHANNELS

BASE 100 LOW WITH THIN COVER

SIDE SLOT



Base 100 Low channel dimensions

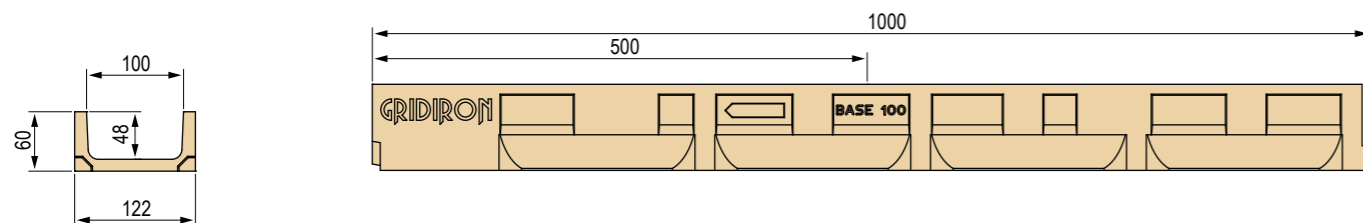

Available Thin covers

N.B.: available on request with 10 mm heelguard slot and in AISI 316 stainless steel

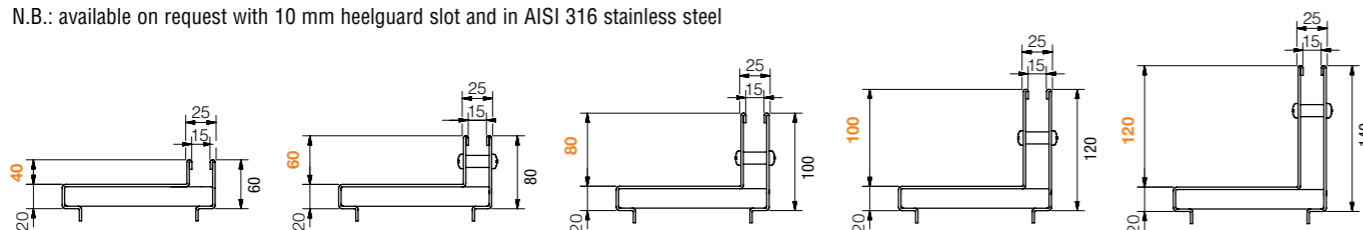

Base 100 Low channel without grating - Length 1,000 / 500 mm

Channel L mm	Code	Description	Water passage mm	Run-off section cm ²	Weight kg	Pieces pallet
1,000	45L5S	Polymer concrete channel	100	46	4.7	loose
500	45L6S	Polymer concrete channel	100	46	2.35	loose

Base 100 Low polymer concrete sump unit without grating

Sump unit L mm	Code	Description	Weight kg
500	4505P	Polymer concrete sump unit L 500 mm	12.50



Thin covers with side slot - Slot width 15 mm

GALVANISED

Cover L mm	Code	Description	Slot height mm	Weight kg	Load class
1,000	4505L0	Thin side cover, hot-dip galvanised, Th. 20/10	40	4.97	C 250
	4505L	Thin side cover, hot-dip galvanised, Th. 20/10	60	5.60	
	4505L1	Thin side cover, hot-dip galvanised, Th. 20/10	80	6.22	D 400
	4505L2	Thin side cover, hot-dip galvanised, Th. 20/10	100	6.85	
	4505L3	Thin side cover, hot-dip galvanised, Th. 20/10	120	7.48	
500	4506L0	Thin side cover, hot-dip galvanised, Th. 20/10	40	2.49	C 250
	4506L	Thin side cover, hot-dip galvanised, Th. 20/10	60	2.80	
	4506L1	Thin side cover, hot-dip galvanised, Th. 20/10	80	3.11	D 400
	4506L2	Thin side cover, hot-dip galvanised, Th. 20/10	100	3.43	
	4506L3	Thin side cover, hot-dip galvanised, Th. 20/10	120	3.74	

N.B.: the Thin cover is supplied loose

AISI 304 STAINLESS STEEL

Cover L mm	Code	Description	Slot height mm	Weight kg	Load class
1,000	4505IL0	Thin side cover, AISI 304 stainless steel, Th. 20/10	40	4.97	C 250
	4505IL	Thin side cover, AISI 304 stainless steel, Th. 20/10	60	5.59	
	4505IL1	Thin side cover, AISI 304 stainless steel, Th. 20/10	80	6.22	D 400
	4505IL2	Thin side cover, AISI 304 stainless steel, Th. 20/10	100	6.85	
	4505IL3	Thin side cover, AISI 304 stainless steel, Th. 20/10	120	7.48	
500	4506IL0	Thin side cover, AISI 304 stainless steel, Th. 20/10	40	2.49	C 250
	4506IL	Thin side cover, AISI 304 stainless steel, Th. 20/10	60	2.80	
	4506IL1	Thin side cover, AISI 304 stainless steel, Th. 20/10	80	3.11	D 400
	4506IL2	Thin side cover, AISI 304 stainless steel, Th. 20/10	100	3.43	
	4506IL3	Thin side cover, AISI 304 stainless steel, Th. 20/10	120	3.74	

N.B.: the Thin cover is supplied loose



Inspection buckets for Thin covers with side slot - Slot width 15 mm

GALVANISED

Bucket L mm	Code	Description	Slot height mm	Weight kg	Load class
500	4506VL0	Inspection bucket for galvanised Thin side cover	40	3.98	C 250
	4506VL	Inspection bucket for galvanised Thin side cover	60	4.69	
	4506VL1	Inspection bucket for galvanised Thin side cover	80	5.39	D 400
	4506VL2	Inspection bucket for galvanised Thin side cover	100	6.10	
	4506VL3	Inspection bucket for galvanised Thin side cover	120	6.80	

N.B.: the Thin bucket is supplied loose

AISI 304 STAINLESS STEEL

Bucket L mm	Code	Description	Slot height mm	Weight kg	Load class
500	4506VLi0	Inspection bucket for Thin side cover made of AISI 304 stainless steel	40	3.98	C 250
	4506VLi	Inspection bucket for Thin side cover made of AISI 304 stainless steel	60	4.69	
	4506VLi1	Inspection bucket for Thin side cover made of AISI 304 stainless steel	80	5.39	D 400
	4506VLi2	Inspection bucket for Thin side cover made of AISI 304 stainless steel	100	6.10	
	4506VLi3	Inspection bucket for Thin side cover made of AISI 304 stainless steel	120	6.80	

N.B.: the Thin bucket is supplied loose

POLYMER CONCRETE CHANNELS

BASE 150

Grating width 200 mm

Polymer concrete channel complying with the UNI EN 1433 standard.
The channels are sold exclusively in complete pallets and together with the gratings.



Base 150 channel dimensions

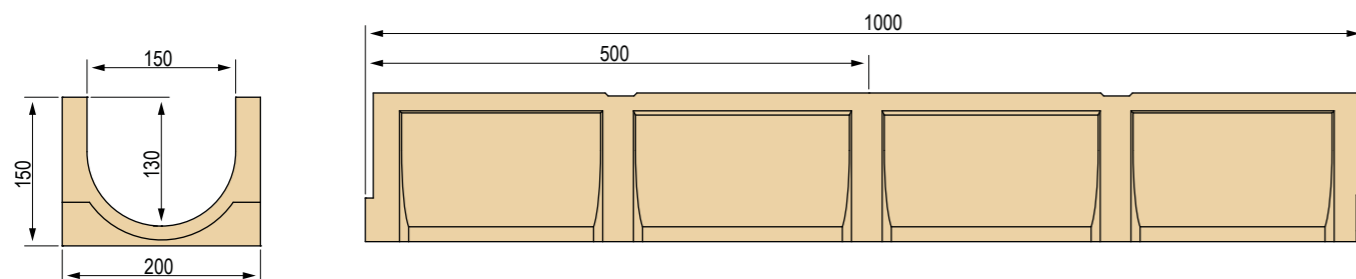

Available gratings

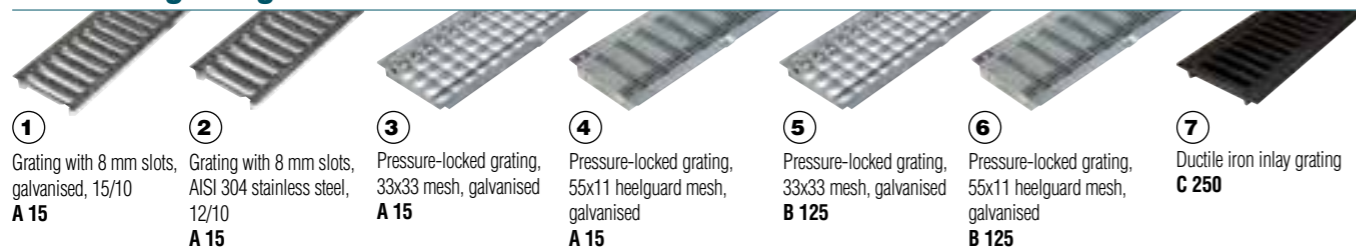

Base 150 channel complete with grating - Length 1,000 / 500 mm

Channel L mm	Code	Grating	Description of the channel assembled with the grating complete with accessories	Weight kg	Load class	
1,000	4510SGL	①	Channel complete with self-locking inlay grating made of press-formed metal sheet, galvanised, 8 mm slots, Th. 15/10	17.57	A 15	
	4510SGLI	②	Channel complete with inlay grating made of AISI 304 stainless steel press-formed metal sheet, 8 mm slots, Th. 12/10	17.67		
	4510SA	③	Channel complete with pressure-locked inlay grating 20x2-10x2 33x33, hot-dip galvanised	17.21		
	500	4510SAA	④	Channel complete with pressure-locked heelguard inlay grating 20x2-10x2 55x11, hot-dip galvanised	18.15	B 125
		4510SB	⑤	Channel complete with pressure-locked inlay grating 30x2-10x2 33x33, hot-dip galvanised	19.27	
		4510SBA	⑥	Channel complete with pressure-locked heelguard inlay grating 30x2-10x2 55x11, hot-dip galvanised	19.61	C 250
		4510SGS	⑦	Channel complete with 2 x GJS500-7 ductile iron inlay gratings	26.23	
500	4511SGL	①	Channel complete with self-locking inlay grating made of press-formed metal sheet, galvanised, 8 mm slots, Th. 15/10	8.79	A 15	
	4511SGLI	②	Channel complete with inlay grating made of AISI 304 stainless steel press-formed metal sheet, 8 mm slots, Th. 12/10	8.84		
	4511SA	③	Channel complete with pressure-locked inlay grating 20x2-10x2 33x33, hot-dip galvanised	8.61		
	500	4511SAA	④	Channel complete with pressure-locked heelguard inlay grating 20x2-10x2 55x11, hot-dip galvanised	9.08	B 125
		4511SB	⑤	Channel complete with pressure-locked inlay grating 30x2-10x2 33x33, hot-dip galvanised	9.64	
		4511SBA	⑥	Channel complete with pressure-locked heelguard inlay grating 30x2-10x2 55x11, hot-dip galvanised	9.81	C 250
		4511SGS	⑦	Channel complete with GJS500-7 ductile iron inlay grating	13.12	

Base 150 accessories



Polymer concrete sump unit

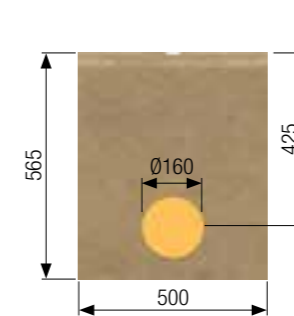

End caps

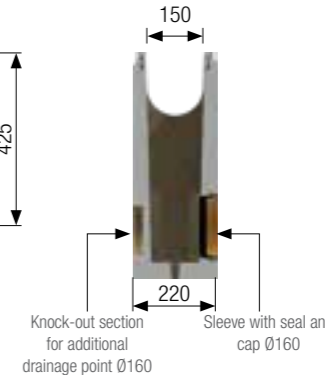

End caps with outlets



Anchoring kit

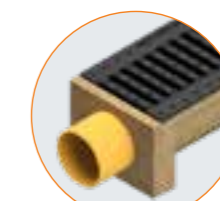
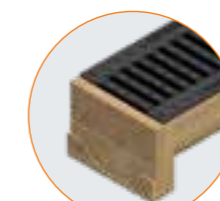

Bucket/filter for sump units

Base 150 polymer concrete sump unit complete with grating - Length 500 mm

Sump unit L mm	Code	Grating	Description of the sump unit assembled with the grating complete with accessories	Weight kg	Load class	
500	4510PGL	①	Sump unit complete with self-locking inlay grating made of press-formed metal sheet, galvanised, 8 mm slots, Th. 15/10	74.05	A 15	
	4510PGLI	②	Sump unit complete with inlay grating made of AISI 304 stainless steel press-formed metal sheet, 8 mm slots, Th. 12/10	74.10		
	4510PA	③	Sump unit complete with pressure-locked inlay grating 20x2-10x2 33x33, hot-dip galvanised	73.87		
	500	4510PAA	④	Sump unit complete with pressure-locked heelguard inlay grating 20x2-10x2 55x11, hot-dip galvanised	74.34	B 125
		4510PB	⑤	Sump unit complete with pressure-locked inlay grating 30x2-10x2 33x33, hot-dip galvanised	74.90	
		4510PBA	⑥	Sump unit complete with pressure-locked heelguard inlay grating 30x2-10x2 55x11, hot-dip galvanised	75.07	C 250
		4510PGS	⑦	Sump unit complete with GJS500-7 ductile iron inlay grating	78.38	

Base 150 polymer concrete sump unit without grating and accessories

Code	Description	Weight kg
4510P	Polymer concrete sump unit L 500 mm	72.25
4R02VI	Bucket/filter, AISI 304 stainless steel	4.10
4510T	End cap for channel	1.31
4510R	End cap with outlet for channel Ø110 mm	1.64
4510K	Kit for anchoring the grating to the channel and sump unit	0.024

Base 150 channel without grating - Length 1,000 / 500 mm

Channel L mm	Code	Description	Water passage mm	Run-off section cm ²	Weight kg	Pieces pallet
1,000	4510S	Polymer concrete channel	150	170.8	13.97	40
500	4511S	Polymer concrete channel	150	170.8	6.45	loose

POLYMER CONCRETE CHANNELS

BASE 150 EVO (with edge rail)

Grating width 200 mm

Polymer concrete channel with galvanised protective edge rail complying with the UNI EN 1433 standard. The channels are sold exclusively in complete pallets and together with the gratings.

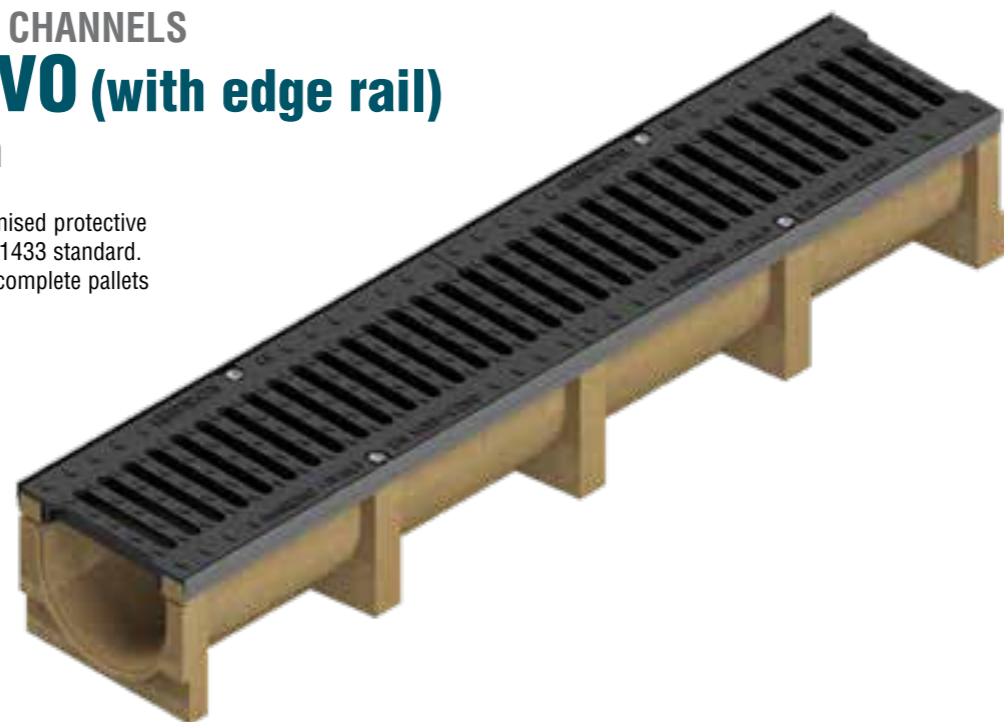

Base 150 EVO channel dimensions

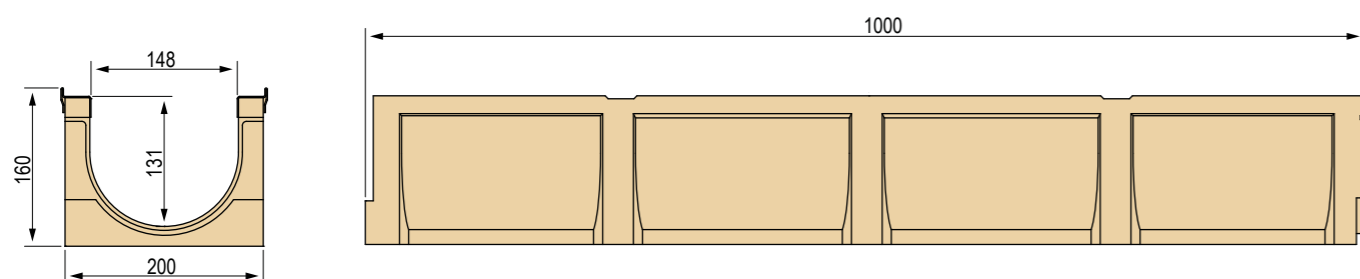

Available grating

GJS500-7 ductile iron inlay grating
C 250



Base 150 EVO channel complete with grating - Length 1,000 mm

Channel L mm	Code	Description of the channel assembled with the grating complete with accessories	Weight kg	Load class
1,000	4510SPS	EVO Series channel with galvanised edge rails, complete with 2 x GJS500-7 ductile iron inlay gratings	27.69	C 250

Base 150 EVO accessories



Polymer concrete sump unit

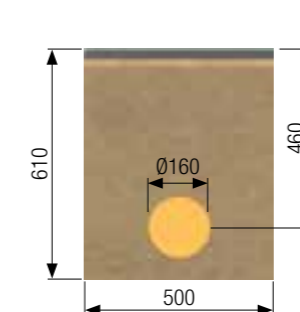

End caps

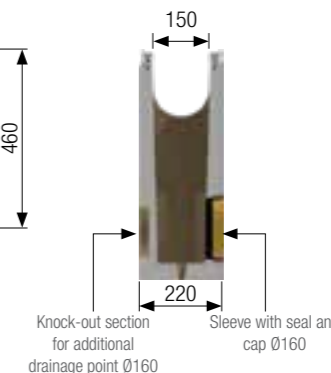

End caps with outlets



Anchoring kit



Bucket/filter for sump units

Base 150 EVO polymer concrete sump unit complete with grating - Length 500 mm

Sump unit L mm	Code	Description of the sump unit assembled with the grating complete with accessories	Weight kg	Load class
500	4510PPS	Sump unit complete with GJS500-7 ductile iron inlay grating	79.11	C 250

Base 150 EVO polymer concrete sump unit without grating and accessories

Code	Description	Weight kg
4510PP	Polymer concrete sump unit L 500 mm	20.45
4R02VI	Bucket/filter, AISI 304 stainless steel	4.10
4510T	End cap for channel	1.31
4510R	End cap with outlet for channel Ø110 mm	1.64
4510K	Kit for anchoring the grating to the channel and sump unit	0.024

Base 150 EVO channel without grating - Length 1,000 mm

Channel L mm	Code	Description	Water passage mm	Run-off section cm ²	Weight kg	Pieces pallet
1,000	4510SP	EVO series channel with galvanised edge rails	150	170.8	15.41	40

POLYMER CONCRETE CHANNELS

BASE 150 WITH THIN COVER

CENTRAL SLOT

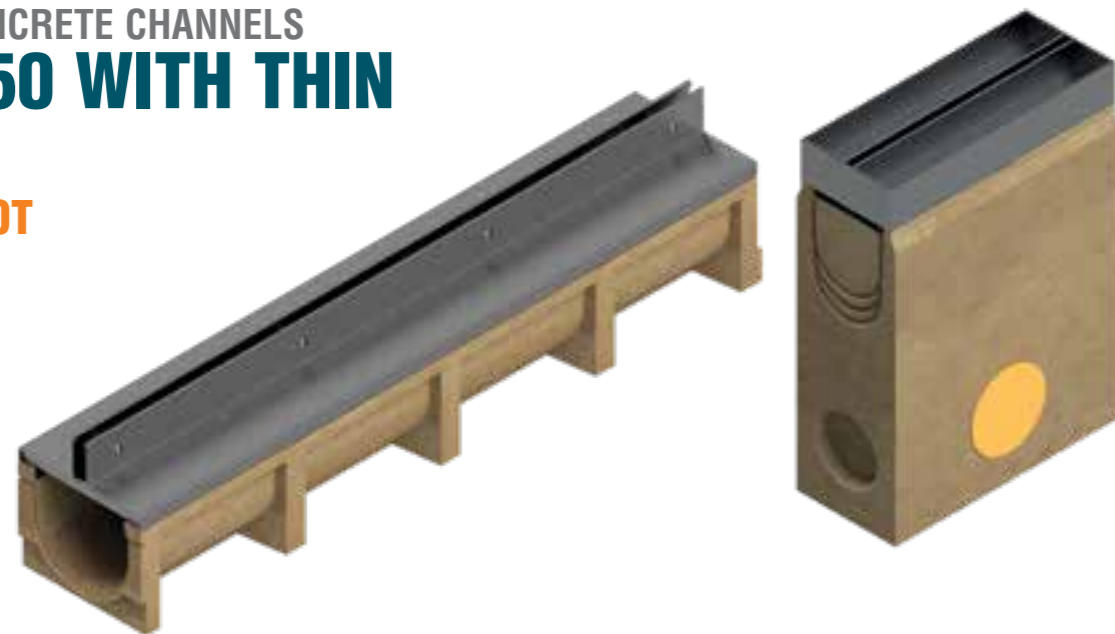

Base 150 channel dimensions

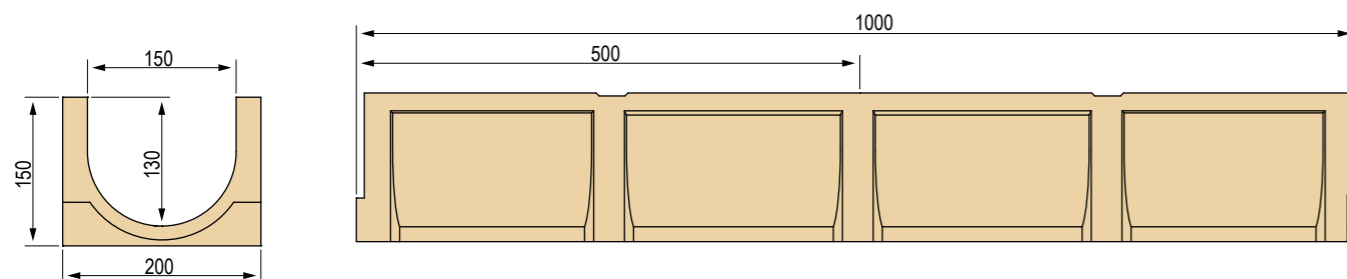

Available Thin covers

N.B.: available on request with 10 mm heelguard slot and in AISI 316 stainless steel

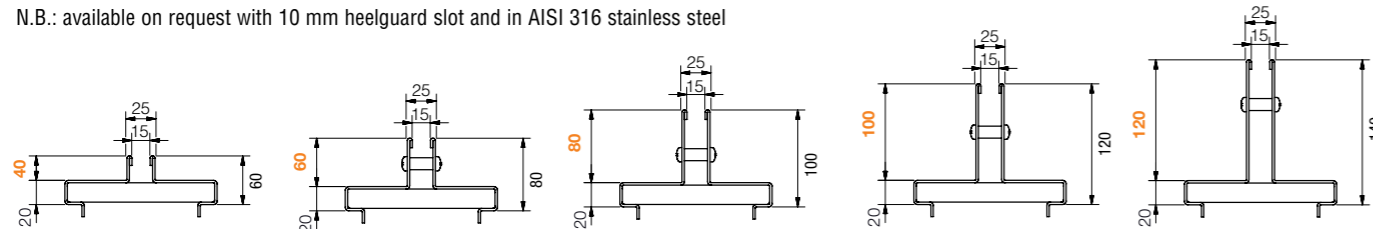

Base 150 channel without grating - Length 1,000 / 500 mm

Channel L mm	Code	Description	Water passage mm	Run-off section cm ²	Weight kg	Pieces pallet
1,000	4510S	Polymer concrete channel	150	170.8	13.97	loose
500	4511S	Polymer concrete channel	150	170.8	6.45	loose

Base 150 polymer concrete sump unit without grating

Sump unit L mm	Code	Description	Weight kg
500	4510P	Polymer concrete sump unit L 500 mm	72.25



Thin covers with central slot - Slot width 15 mm

GALVANISED

Cover L mm	Code	Description	Slot height mm	Weight kg	Load class
1,000	4510T0	Thin central cover, hot-dip galvanised, Th. 20/10	40	6.73	C 250
	4510PT	Thin central cover, hot-dip galvanised, Th. 20/10	60	7.36	
	4510T1	Thin central cover, hot-dip galvanised, Th. 20/10	80	7.99	D 400
	4510T2	Thin central cover, hot-dip galvanised, Th. 20/10	100	8.61	
	4510T3	Thin central cover, hot-dip galvanised, Th. 20/10	120	9.24	
500	4511T0	Thin central cover, hot-dip galvanised, Th. 20/10	40	3.37	C 250
	4511T	Thin central cover, hot-dip galvanised, Th. 20/10	60	3.68	
	4511T1	Thin central cover, hot-dip galvanised, Th. 20/10	80	4.00	D 400
	4511T2	Thin central cover, hot-dip galvanised, Th. 20/10	100	4.31	
	4511T3	Thin central cover, hot-dip galvanised, Th. 20/10	120	4.62	

N.B.: the Thin cover is supplied loose

AISI 304 STAINLESS STEEL

Cover L mm	Code	Description	Slot height mm	Weight kg	Load class
1,000	4510I0	Thin central cover, AISI 304 stainless steel, Th. 20/10	40	6.73	C 250
	4510I	Thin central cover, AISI 304 stainless steel, Th. 20/10	60	7.36	
	4510I1	Thin central cover, AISI 304 stainless steel, Th. 20/10	80	7.99	D 400
	4510I2	Thin central cover, AISI 304 stainless steel, Th. 20/10	100	8.61	
	4510I3	Thin central cover, AISI 304 stainless steel, Th. 20/10	120	9.24	
500	4511I0	Thin central cover, AISI 304 stainless steel, Th. 20/10	40	3.37	C 250
	4511I	Thin central cover, AISI 304 stainless steel, Th. 20/10	60	3.68	
	4511I1	Thin central cover, AISI 304 stainless steel, Th. 20/10	80	4.00	D 400
	4511I2	Thin central cover, AISI 304 stainless steel, Th. 20/10	100	4.31	
	4511I3	Thin central cover, AISI 304 stainless steel, Th. 20/10	120	4.62	

N.B.: the Thin cover is supplied loose



Inspection buckets for Thin covers with central slot - Slot width 15 mm

GALVANISED

Bucket L mm	Code	Description	Slot height mm	Weight kg	Load class
500	4511V0	Inspection bucket for galvanised Thin central cover	40	5.13	C 250
	4511V	Inspection bucket for galvanised Thin central cover	60	5.88	
	4511V1	Inspection bucket for galvanised Thin central cover	80	6.63	D 400
	4511V2	Inspection bucket for galvanised Thin central cover	100	7.37	
	4511V3	Inspection bucket for galvanised Thin central cover	120	8.12	

N.B.: the Thin bucket is supplied loose

AISI 304 STAINLESS STEEL

Bucket L mm	Code	Description	Slot height mm	Weight kg	Load class
500	4511VI0	Inspection bucket for Thin central cover made of AISI 304 stainless steel	40	5.13	C 250
	4511VI	Inspection bucket for Thin central cover made of AISI 304 stainless steel	60	5.88	
	4511VI1	Inspection bucket for Thin central cover made of AISI 304 stainless steel	80	6.63	D 400
	4511VI2	Inspection bucket for Thin central cover made of AISI 304 stainless steel	100	7.37	
	4511VI3	Inspection bucket for Thin central cover made of AISI 304 stainless steel	120	8.12	

N.B.: the Thin bucket is supplied loose

POLYMER CONCRETE CHANNELS

BASE 150 WITH THIN COVER

SIDE SLOT

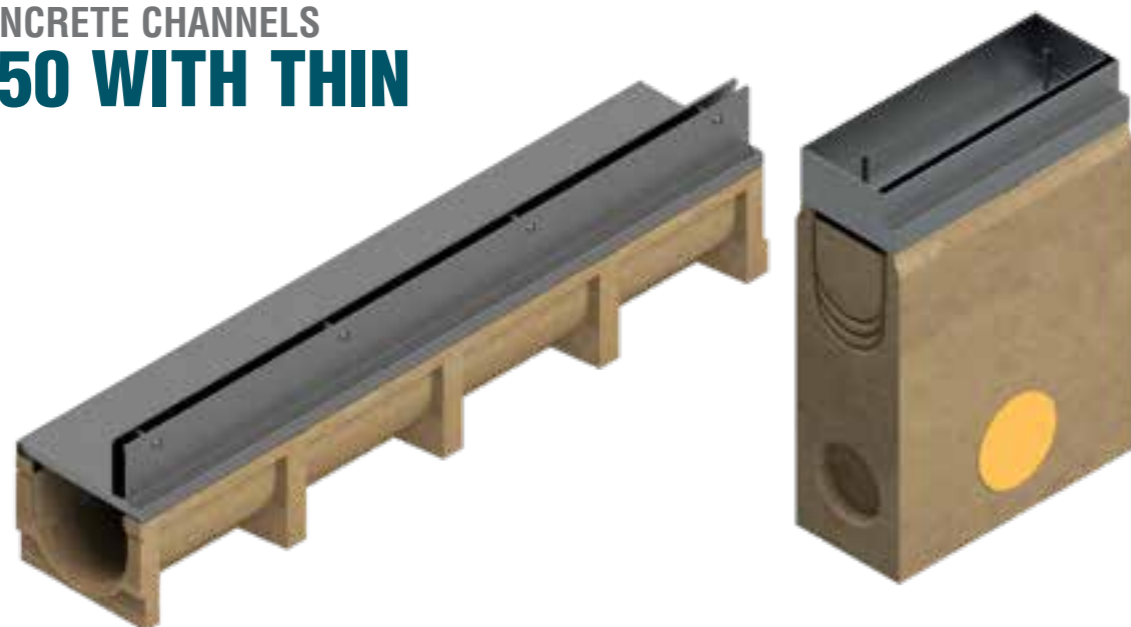

Base 150 channel dimensions

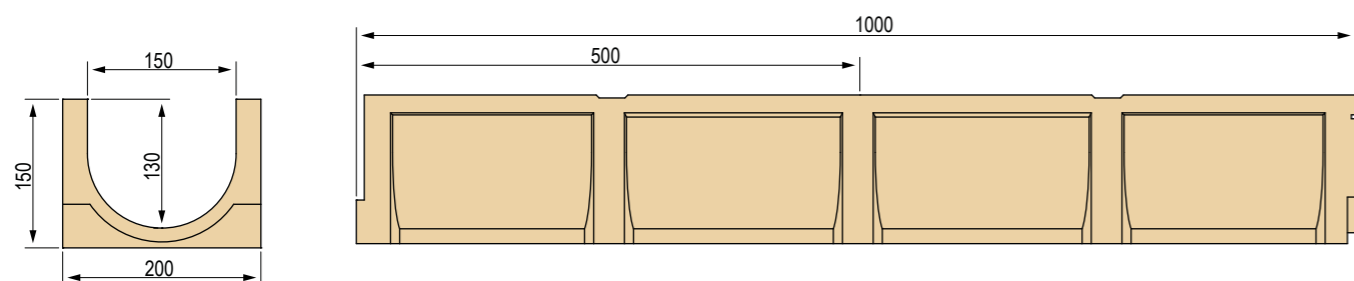

Available Thin covers

N.B.: available on request with 10 mm heelguard slot and in AISI 316 stainless steel

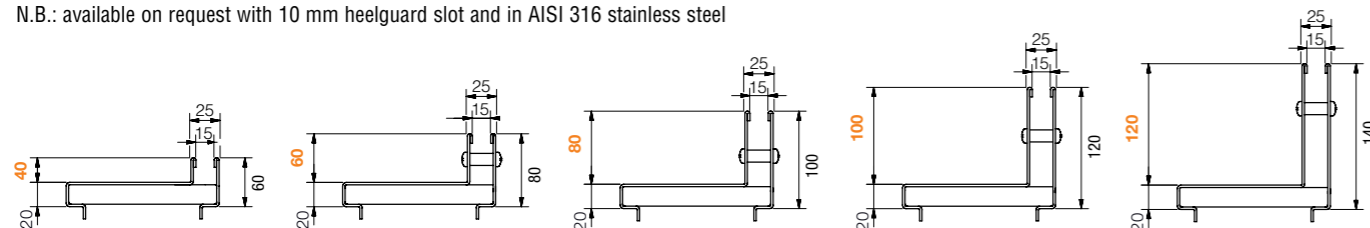

Base 150 channel without grating - Length 1,000 / 500 mm

Channel L mm	Code	Description	Water passage mm	Run-off section cm ²	Weight kg	Pieces pallet
1,000	4510S	Polymer concrete channel	150	170.8	13.97	loose
500	4511S	Polymer concrete channel	150	170.8	6.45	loose

Base 150 polymer concrete sump unit without grating

Sump unit L mm	Code	Description	Weight kg
500	4510P	Polymer concrete sump unit L 500 mm	72.25

Thin covers with side slot - Slot width 15 mm

GALVANISED

Cover L mm	Code	Description	Slot height mm	Weight kg	Load class
1,000	4510L0	Thin side cover, hot-dip galvanised, Th. 20/10	40	6.73	C 250
	4510L	Thin side cover, hot-dip galvanised, Th. 20/10	60	7.36	
	4510L1	Thin side cover, hot-dip galvanised, Th. 20/10	80	7.99	D 400
	4510L2	Thin side cover, hot-dip galvanised, Th. 20/10	100	8.61	
	4510L3	Thin side cover, hot-dip galvanised, Th. 20/10	120	9.24	
500	4511L0	Thin side cover, hot-dip galvanised, Th. 20/10	40	3.37	C 250
	4511L	Thin side cover, hot-dip galvanised, Th. 20/10	60	3.68	
	4511L1	Thin side cover, hot-dip galvanised, Th. 20/10	80	4.00	D 400
	4511L2	Thin side cover, hot-dip galvanised, Th. 20/10	100	4.31	
	4511L3	Thin side cover, hot-dip galvanised, Th. 20/10	120	4.62	

N.B.: the Thin cover is supplied loose

AISI 304 STAINLESS STEEL

Cover L mm	Code	Description	Slot height mm	Weight kg	Load class
1,000	4510IL0	Thin side cover made of AISI 304 stainless steel Th. 20/10	40	6.73	C 250
	4510IL	Thin side cover made of AISI 304 stainless steel Th. 20/10	60	7.36	
	4510IL1	Thin side cover made of AISI 304 stainless steel Th. 20/10	80	7.99	D 400
	4510IL2	Thin side cover made of AISI 304 stainless steel Th. 20/10	100	8.61	
	4510IL3	Thin side cover made of AISI 304 stainless steel Th. 20/10	120	9.24	
500	4511IL0	Thin side cover made of AISI 304 stainless steel Th. 20/10	40	3.37	C 250
	4511IL	Thin side cover made of AISI 304 stainless steel Th. 20/10	60	3.68	
	4511IL1	Thin side cover made of AISI 304 stainless steel Th. 20/10	80	4.00	D 400
	4511IL2	Thin side cover made of AISI 304 stainless steel Th. 20/10	100	4.31	
	4511IL3	Thin side cover made of AISI 304 stainless steel Th. 20/10	120	4.62	

N.B.: the Thin cover is supplied loose

Inspection buckets for Thin covers with side slot - Slot width 15 mm

GALVANISED

Bucket L mm	Code	Description	Slot height mm	Weight kg	Load class
500	4511VL0	Inspection bucket for galvanised Thin side cover	40	5.13	C 250
	4511VL	Inspection bucket for galvanised Thin side cover	60	5.88	
	4511VL1	Inspection bucket for galvanised Thin side cover	80	6.63	D 400
	4511VL2	Inspection bucket for galvanised Thin side cover	100	7.37	
	4511VL3	Inspection bucket for galvanised Thin side cover	120	8.12	

N.B.: the Thin bucket is supplied loose

AISI 304 STAINLESS STEEL

Bucket L mm	Code	Description	Slot height mm	Weight kg	Load class
500	4511VLi0	Inspection bucket for Thin side cover made of AISI 304 stainless steel	40	5.13	C 250
	4511VLi	Inspection bucket for Thin side cover made of AISI 304 stainless steel	60	5.88	
	4511VLi1	Inspection bucket for Thin side cover made of AISI 304 stainless steel	80	6.63	D 400
	4511VLi2	Inspection bucket for Thin side cover made of AISI 304 stainless steel	100	7.37	
	4511VLi3	Inspection bucket for Thin side cover made of AISI 304 stainless steel	120	8.12	

N.B.: the Thin bucket is supplied loose

POLYMER CONCRETE CHANNELS BASE 200

Grating width 250 mm

Polymer concrete channel complying with the UNI EN 1433 standard.
The channels are sold exclusively in complete pallets and together with the gratings.



Base 200 channel dimensions

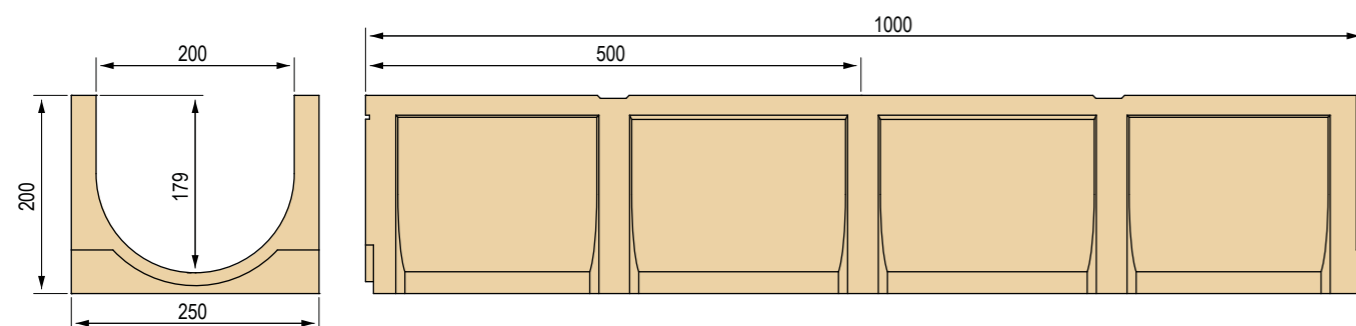

Available gratings

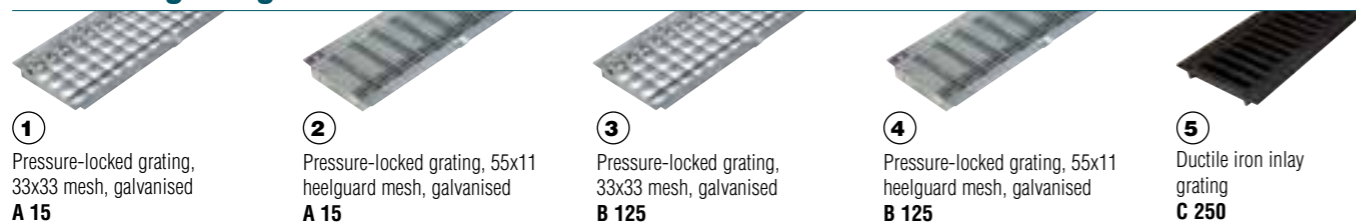

Base 200 channel complete with grating - Length 1,000 / 500 mm

Channel L mm	Code	Grating	Description of the channel assembled with the grating complete with accessories	Weight kg	Load class
1,000	4520SA	①	Channel complete with pressure-locked inlay grating 30x2-10x2 33x33, hot-dip galvanised	26.38	A 15
	4520SAA	②	Channel complete with pressure-locked heelguard inlay grating 30x2-10x2 55x11, hot-dip galvanised	27.43	
	4520SB	③	Channel complete with pressure-locked inlay grating 40x2-10x2 33x33, hot-dip galvanised	28.92	B 125
	4520SBA	④	Channel complete with pressure-locked inlay gratings 40x2-10x2 55x11 heelguard mesh, hot-dip galvanised	28.86	
	4520SGS	⑤	Channel complete with 2 x GJS500-7 ductile iron inlay gratings	42.46	C 250
500	4521SA	①	Channel complete with pressure-locked inlay grating 30x2-10x2 33x33, hot-dip galvanised	13.19	A 15
	4521SAA	②	Channel complete with pressure-locked heelguard inlay grating 30x2-10x2 55x11, hot-dip galvanised	13.72	
	4521SB	③	Channel complete with pressure-locked inlay grating 40x2-10x2 33x33, hot-dip galvanised	14.46	B 125
	4521SBA	④	Channel complete with pressure-locked inlay grating 40x2-10x2 55x11 heelguard mesh, hot-dip galvanised	14.43	
	4521SGS	⑤	Channel complete with GJS500-7 ductile iron inlay grating	21.23	C 250

Base 200 accessories

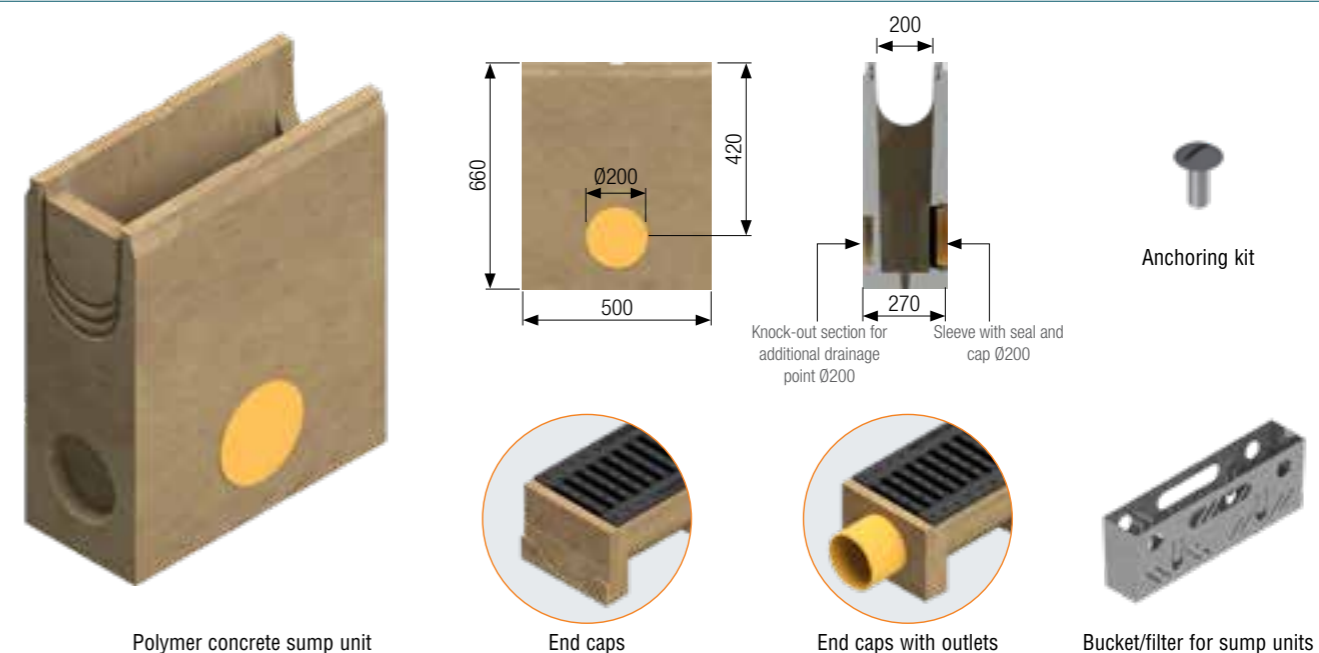

Base 200 polymer concrete sump unit complete with grating - Length 500 mm

Sump unit L mm	Code	Grating	Description of the sump unit assembled with the grating complete with accessories	Weight kg	Load class
500	4520PA	①	Sump unit complete with pressure-locked inlay grating 30x2-10x2 33x33, hot-dip galvanised	99.40	A 15
	4520PAA	②	Sump unit complete with pressure-locked heelguard inlay grating 30x2-10x2 55x11, hot-dip galvanised	99.93	
	4520PB	③	Sump unit complete with pressure-locked inlay grating 40x2-10x2 33x33, hot-dip galvanised	100.67	B 125
	4520PBA	④	Sump unit complete with pressure-locked heelguard inlay grating 40x2-10x2 55x11, hot-dip galvanised	100.64	
	4520PGS	⑤	Sump unit complete with GJS500-7 ductile iron inlay grating	107.44	C 250

Base 200 polymer concrete sump unit without grating and accessories

Code	Description	Weight kg
4520P	Polymer concrete sump unit L 500 mm	96.80
4R03VI	Bucket/filter, AISI 304 stainless steel	4.10
4520T	End cap for channel	2.05
4520R	End cap with outlet for channel Ø110 mm	2.38
4520K	Kit for anchoring the grating to the channel and sump unit	0.03

Base 200 channel without grating - Length 1,000 / 500 mm

Channel L mm	Code	Description	Water passage mm	Run-off section cm ²	Weight kg	Pieces pallet
1,000	4520S	Polymer concrete channel	200	315.1	21.18	24
500	4521S	Polymer concrete channel	200	315.1	10.2	loose

POLYMER CONCRETE CHANNELS **BASE 200 EVO (with edge rails)**

Grating width 250 mm

Polymer concrete channel with galvanised protective edge rails complying with the UNI EN 1433 standard. The channels are sold exclusively in complete pallets and together with the gratings.

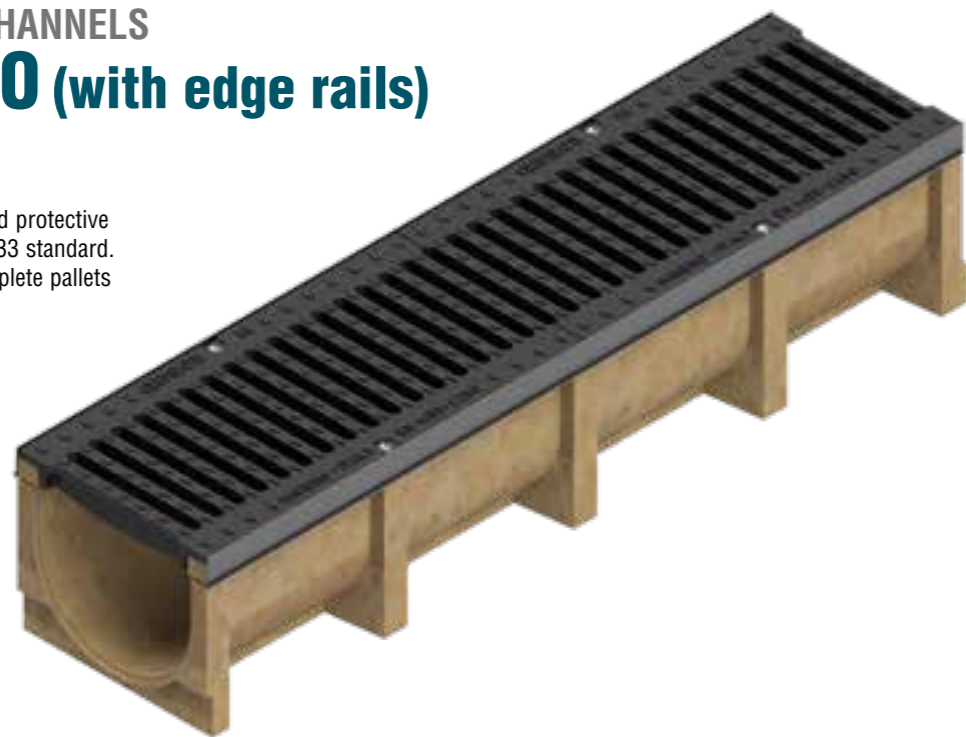

Base 200 EVO channel dimensions

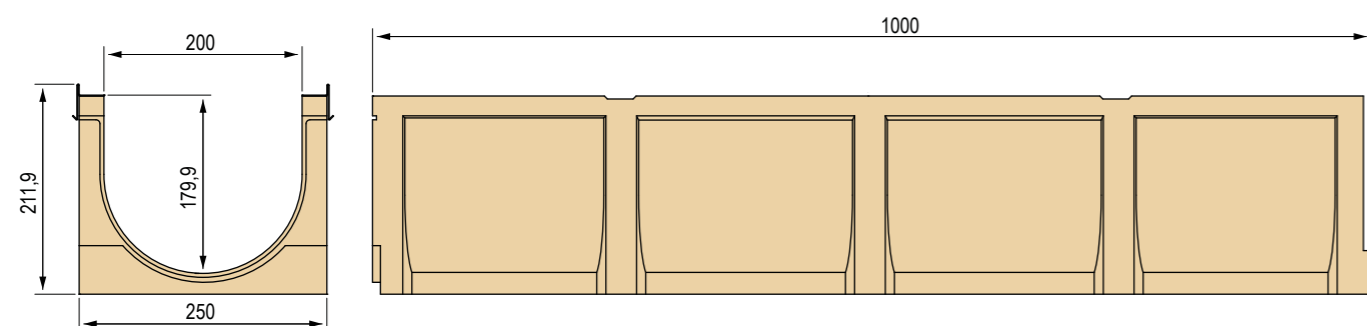

Available grating

GJS500-7 ductile iron
inlay grating
C 250



Base 200 EVO channel complete with grating - Length 1,000 mm

Channel L mm	Code	Description of the channel assembled with the grating complete with accessories	Weight kg	Load class
1,000	4520SPS	EVO Series channel with galvanised edge rails, complete with 2 x GJS500-7 ductile iron inlay gratings	44.12	C 250

Base 200 EVO accessories

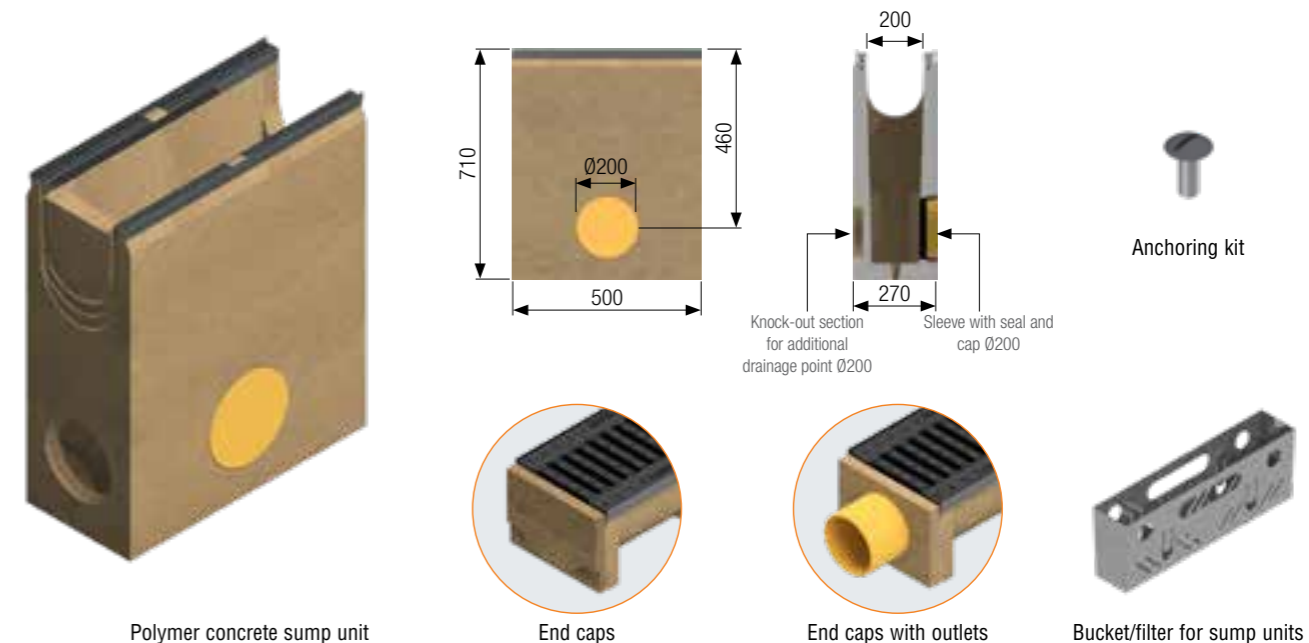

Base 200 EVO polymer concrete sump unit complete with grating - Length 500 mm

Sump unit L mm	Code	Description of the sump unit assembled with the grating complete with accessories	Weight kg	Load class
500	4520PPS	Sump unit complete with GJS500-7 ductile iron inlay grating	108.27	C 250

Base 200 EVO polymer concrete sump unit without grating and accessories

Code	Description	Weight kg
4520PP	Polymer concrete sump unit L 500 mm	97.63
4R03VI	Bucket/filter, AISI 304 stainless steel	4.10
4520T	End cap for channel	2.05
4520R	End cap with outlet for channel Ø110 mm	2.38
4520K	Kit for anchoring the grating to the channel and sump unit	0.024

Base 200 EVO channel without grating - Length 1,000 mm

Channel L mm	Code	Description	Water passage mm	Run-off section cm ²	Weight kg	Pieces pallet
1,000	4520SP	EVO series channel with galvanised edge rails	200	315.1	22.84	24

POLYMER CONCRETE CHANNELS

BASE 200 WITH THIN COVER

CENTRAL SLOT

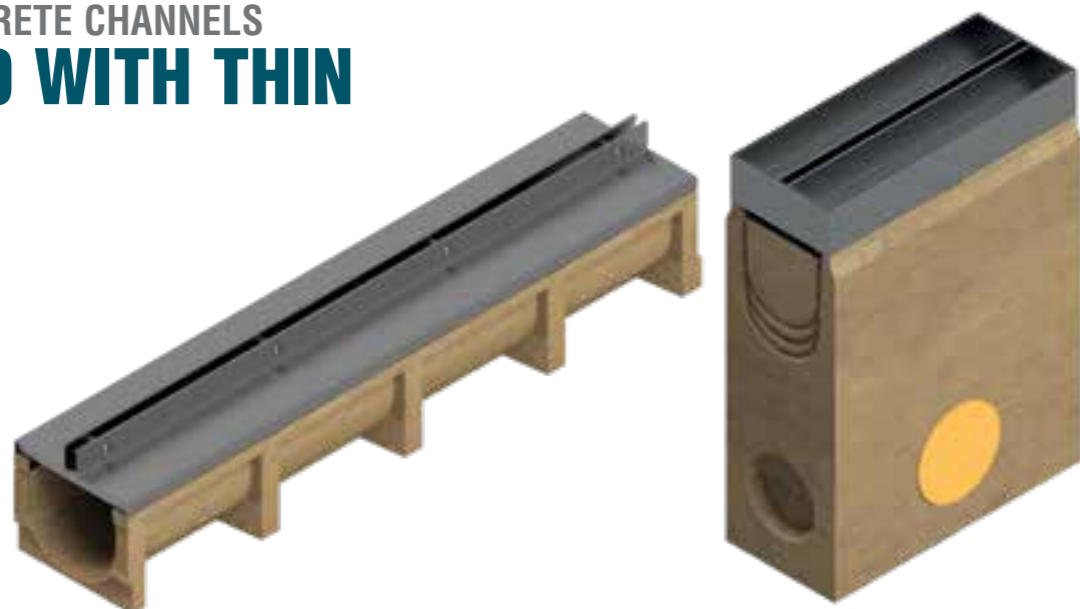

Base 200 channel dimensions

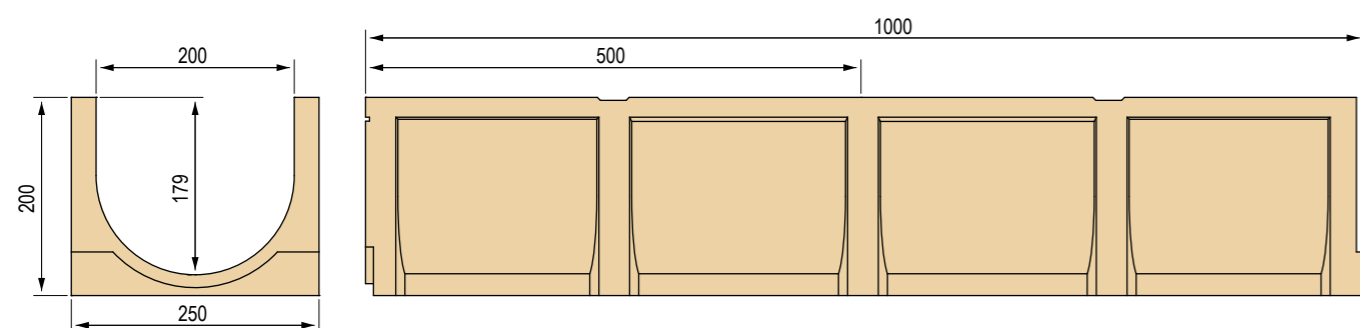

Available Thin covers

N.B.: available on request with 10 mm heelguard slot and in AISI 316 stainless steel

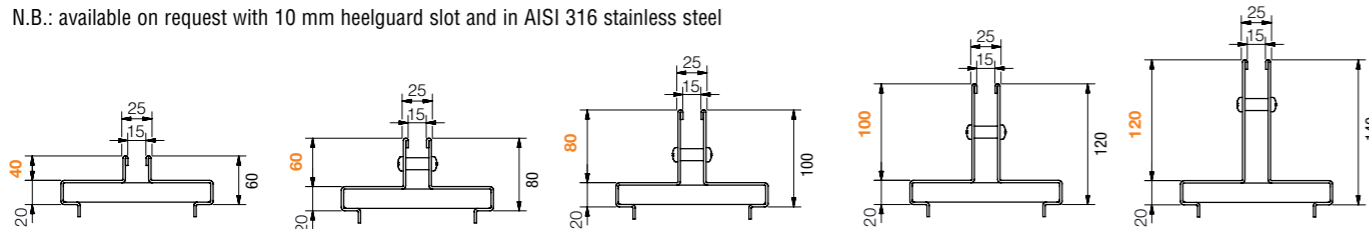

Base 200 channel without grating - Length 1,000 / 500 mm

Channel L mm	Code	Description	Water passage mm	Run-off section cm ²	Weight kg	Pieces pallet
1,000	4520S	Polymer concrete channel	200	315.1	21.18	loose
500	4521S	Polymer concrete channel	200	315.1	10.2	loose

Base 200 polymer concrete sump unit without grating

Sump unit L mm	Code	Description	Weight kg
500	4520P	Polymer concrete sump unit L 500 mm	96.80



Thin covers with central slot - Slot width 15 mm

GALVANISED

Cover L mm	Code	Description	Slot height mm	Weight kg	Load class
1,000	4520T0	Thin central cover, hot-dip galvanised, Th. 20/10	40	7.77	C 250
	4520PT	Thin central cover, hot-dip galvanised, Th. 20/10	60	8.40	
	4520T1	Thin central cover, hot-dip galvanised, Th. 20/10	80	9.03	D 400
	4520T2	Thin central cover, hot-dip galvanised, Th. 20/10	100	9.65	
	4520T3	Thin central cover, hot-dip galvanised, Th. 20/10	120	10.28	
500	4521T0	Thin central cover, hot-dip galvanised, Th. 20/10	40	3.89	C 250
	4521T	Thin central cover, hot-dip galvanised, Th. 20/10	60	4.20	
	4521T1	Thin central cover, hot-dip galvanised, Th. 20/10	80	4.51	D 400
	4521T2	Thin central cover, hot-dip galvanised, Th. 20/10	100	4.83	
	4521T3	Thin central cover, hot-dip galvanised, Th. 20/10	120	5.14	

N.B.: the Thin cover is supplied loose

AISI 304 STAINLESS STEEL

Cover L mm	Code	Description	Slot height mm	Weight kg	Load class
1,000	4520I0	Thin central cover, AISI 304 stainless steel, Th. 20/10	40	7.77	C 250
	4520I	Thin central cover, AISI 304 stainless steel, Th. 20/10	60	8.40	
	4520I1	Thin central cover, AISI 304 stainless steel, Th. 20/10	80	9.03	D 400
	4520I2	Thin central cover, AISI 304 stainless steel, Th. 20/10	100	9.66	
	4520I3	Thin central cover, AISI 304 stainless steel, Th. 20/10	120	10.28	
500	4521I0	Thin central cover, AISI 304 stainless steel, Th. 20/10	40	3.89	C 250
	4521I	Thin central cover, AISI 304 stainless steel, Th. 20/10	60	4.20	
	4521I1	Thin central cover, AISI 304 stainless steel, Th. 20/10	80	4.52	D 400
	4521I2	Thin central cover, AISI 304 stainless steel, Th. 20/10	100	4.83	
	4521I3	Thin central cover, AISI 304 stainless steel, Th. 20/10	120	5.14	

N.B.: the Thin cover is supplied loose



Inspection buckets for Thin covers with central slot - Slot width 15 mm

GALVANISED

Bucket L mm	Code	Description	Slot height mm	Weight kg	Load class
500	4521V0	Inspection bucket for galvanised Thin central cover	40	5.83	C 250
	4521V	Inspection bucket for galvanised Thin central cover	60	6.61	
	4521V1	Inspection bucket for galvanised Thin central cover	80	7.39	D 400
	4521V2	Inspection bucket for galvanised Thin central cover	100	8.17	
	4521V3	Inspection bucket for galvanised Thin central cover	120	8.96	

N.B.: the Thin bucket is supplied loose

AISI 304 STAINLESS STEEL

Bucket L mm	Code	Description	Slot height mm	Weight kg	Load class
500	4521VI0	Inspection bucket for Thin central cover made of AISI 304 stainless steel	40	5.83	C 250
	4521VI	Inspection bucket for Thin central cover made of AISI 304 stainless steel	60	6.61	
	4521VI1	Inspection bucket for Thin central cover made of AISI 304 stainless steel	80	7.39	D 400
	4521VI2	Inspection bucket for Thin central cover made of AISI 304 stainless steel	100	8.17	
	4521VI3	Inspection bucket for Thin central cover made of AISI 304 stainless steel	120	8.96	

N.B.: the Thin bucket is supplied loose

POLYMER CONCRETE CHANNELS

BASE 200 WITH THIN COVER

SIDE SLOT

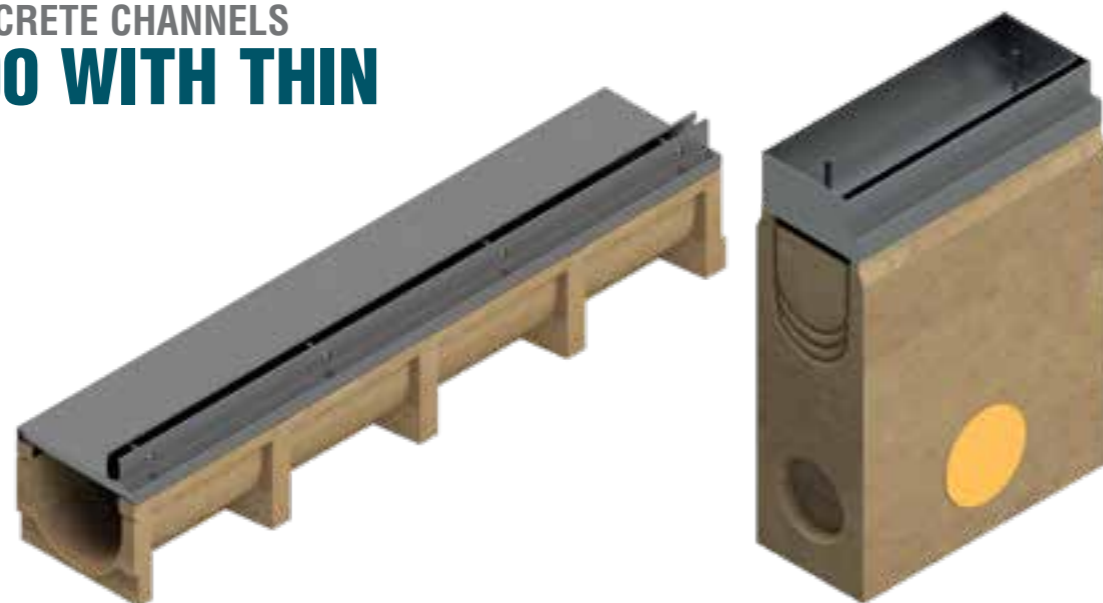

Base 200 channel dimensions

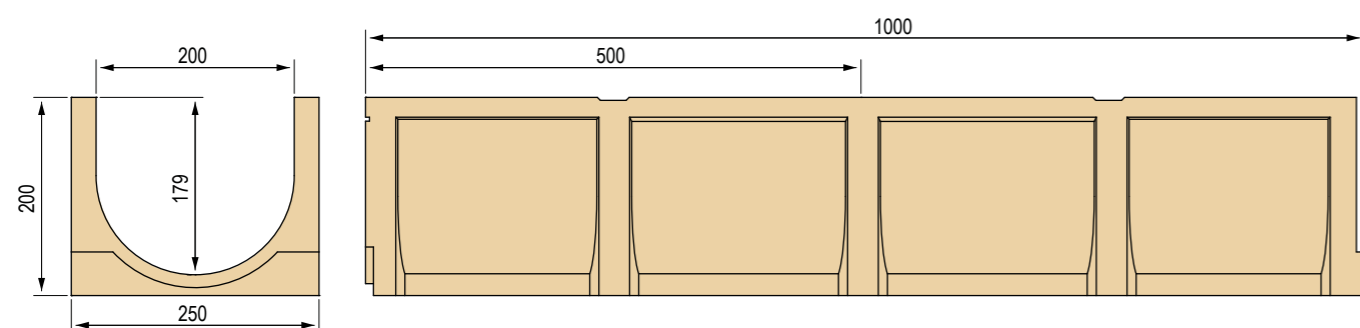

Available Thin covers

N.B.: available on request with 10 mm heelguard slot and in AISI 316 stainless steel

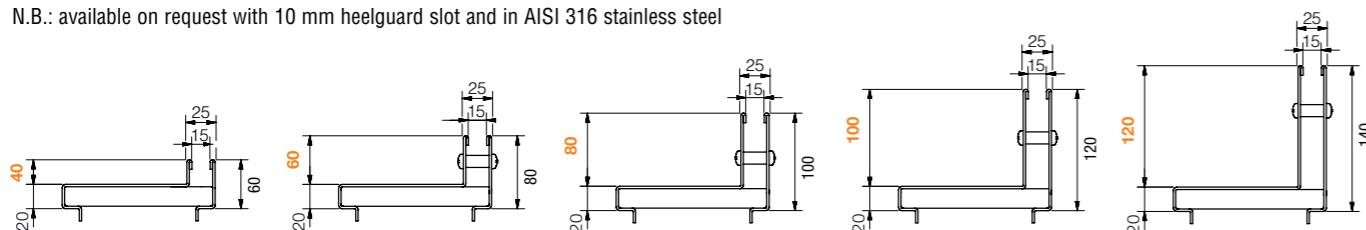

Base 200 channel without grating - Length 1,000 / 500 mm

Channel L mm	Code	Description	Water passage mm	Run-off section cm ²	Weight kg	Pieces pallet
1,000	4520S	Polymer concrete channel	200	315.1	21.18	loose
500	4521S	Polymer concrete channel	200	315.1	10.2	loose

Base 200 polymer concrete sump unit without grating

Sump unit L mm	Code	Description	Weight kg
500	4520P	Polymer concrete sump unit L 500 mm	96.80



Thin covers with side slot - Slot width 15 mm

GALVANISED

Cover L mm	Code	Description	Slot height mm	Weight kg	Load class
1,000	4520L0	Thin side cover, hot-dip galvanised, Th. 20/10	40	7.77	C 250
	4520L	Thin side cover, hot-dip galvanised, Th. 20/10	60	8.40	
	4520L1	Thin side cover, hot-dip galvanised, Th. 20/10	80	9.03	D 400
	4520L2	Thin side cover, hot-dip galvanised, Th. 20/10	100	9.65	
	4520L3	Thin side cover, hot-dip galvanised, Th. 20/10	120	10.28	
500	4521L0	Thin side cover, hot-dip galvanised, Th. 20/10	40	3.89	C 250
	4521L	Thin side cover, hot-dip galvanised, Th. 20/10	60	4.20	
	4521L1	Thin side cover, hot-dip galvanised, Th. 20/10	80	4.51	D 400
	4521L2	Thin side cover, hot-dip galvanised, Th. 20/10	100	4.83	
	4521L3	Thin side cover, hot-dip galvanised, Th. 20/10	120	5.14	

N.B.: the Thin cover is supplied loose

AISI 304 STAINLESS STEEL

Cover L mm	Code	Description	Slot height mm	Weight kg	Load class
1,000	4520IL0	Thin side cover made of AISI 304 stainless steel Th. 20/10	40	7.77	C 250
	4520IL	Thin side cover made of AISI 304 stainless steel Th. 20/10	60	8.40	
	4520IL1	Thin side cover made of AISI 304 stainless steel Th. 20/10	80	9.03	D 400
	4520IL2	Thin side cover made of AISI 304 stainless steel Th. 20/10	100	9.66	
	4520IL3	Thin side cover made of AISI 304 stainless steel Th. 20/10	120	10.28	
500	4521IL0	Thin side cover made of AISI 304 stainless steel Th. 20/10	40	3.89	C 250
	4521IL	Thin side cover made of AISI 304 stainless steel Th. 20/10	60	4.20	
	4521IL1	Thin side cover made of AISI 304 stainless steel Th. 20/10	80	4.52	D 400
	4521IL2	Thin side cover made of AISI 304 stainless steel Th. 20/10	100	4.83	
	4521IL3	Thin side cover made of AISI 304 stainless steel Th. 20/10	120	5.14	

N.B.: the Thin cover is supplied loose



Inspection buckets for Thin covers with side slot - Slot width 15 mm

GALVANISED

Bucket L mm	Code	Description	Slot height mm	Weight kg	Load class
500	4521VL0	Inspection bucket for galvanised Thin side cover	40	5.83	C 250
	4521VL	Inspection bucket for galvanised Thin side cover	60	6.61	
	4521VL1	Inspection bucket for galvanised Thin side cover	80	7.39	D 400
	4521VL2	Inspection bucket for galvanised Thin side cover	100	8.17	
	4521VL3	Inspection bucket for galvanised Thin side cover	120	8.96	

N.B.: the Thin bucket is supplied loose

AISI 304 STAINLESS STEEL

Bucket L mm	Code	Description	Slot height mm	Weight kg	Load class
500	4521VL10	Inspection bucket for Thin side cover made of AISI 304 stainless steel	40	5.83	C 250
	4521VLI	Inspection bucket for Thin side cover made of AISI 304 stainless steel	60	6.61	
	4521VLI1	Inspection bucket for Thin side cover made of AISI 304 stainless steel	80	7.39	D 400
	4521VLI2	Inspection bucket for Thin side cover made of AISI 304 stainless steel	100	8.17	
	4521VLI3	Inspection bucket for Thin side cover made of AISI 304 stainless steel	120	8.96	

N.B.: the Thin bucket is supplied loose

P

POLYMER CONCRETE CHANNELS

SERIES

POLYMER CONCRETE CHANNELS

Thanks to its commitment and on-going research, Gridiron and its staff of chemical industry specialists have expanded the existing range of polymer concrete channels with additional ranges of new-generation, cutting-edge products. Laboratory tests are carried out on a regular basis to verify compliance of the products with the UNI EN 1433 STANDARD.

The channels are made of cast polymer concrete, obtained through a mixture of inert quartz materials and polymer resins with the addition of catalysts. The resulting product is lightweight, smooth and has precise dimensions. It is supplied with the housing for the grating and is configured for anchoring the latter through innovative locking systems. Recommended for use in the road construction, chemical and food processing industries.

The GJS500-7 ductile iron gratings, resting on galvanised steel edge rails, are secured with a special mechanical fastening system creating a unified structure, which helps to uniformly distribute the stress created by the passage of vehicles, while guaranteeing stability and silence.

The classification and control procedures comply with the European UNI EN 1433 standard.



- P 150
- P 150 LOWERED
- P 210
- P 210 LOWERED
- P 265
- P 315
- P 365



LOAD CLASSES

In accordance with the UNI EN 1433 standard

A 15 • B 125 • C 250 • D 400 • E 600 • F 900



POLYMER CONCRETE CHANNELS
P SERIES

SYSTEM AND TECHNICAL CHARACTERISTICS

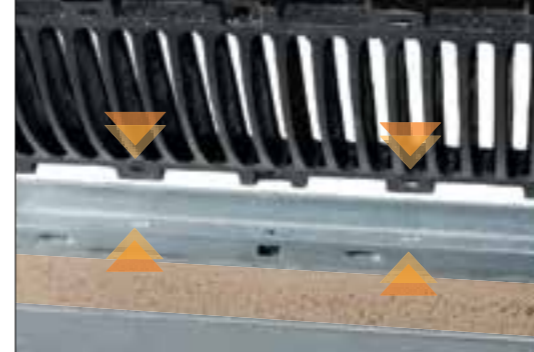

DUCTILE IRON GRATINGS SECURED TO THE CHANNEL

The ductile iron gratings secured to the channel have four relief notches along their lower section which slot into the relative housings on the protective edge rail of the channel to prevent their longitudinal movement.



DUCTILE IRON GRATINGS

For load classes D 400 - E 600, with the possibility of coating them in RAL colours on request

ASSORTED GRATINGS

Made of press-formed metal sheet with heelguard mesh, for load classes A 15 - B 125 - C 250

LOCKING SCREWS
made of stainless steel

BUCKET/FILTER
th. 10/10, AISI 304 stainless steel

END CAP
for channel

KNOCK-OUT SECTIONS
to adapt the sump units to channels or for any other drainage points (configured for Ø125 pipes)

POLYMER CONCRETE CHANNEL



MAXIMUM SAFETY

All P SERIES channels must be installed according to the instructions envisaged in the UNI EN 1433 standard. To facilitate this operation, GRIDIRON has created four recesses on each side of the product for improved anchoring to the support and, above all, for easier positioning of the product with the aid of specific equipment, thereby reducing the application time and effort.

END CAP
with outlet

SUMP UNIT
made of polymer concrete

CONNECTOR SLEEVE
with relative cap

SPECIAL SUMP UNIT COMPONENTS

Bucket/filter fastened with 2 screws ensuring maximum stability and functionality.

Full and safe drainage through the PVC sleeve; knock-out sections are also included to connect Ø125 pipes

Knock-out sections configured for optimal connection to channels. There are also other knock-out sections for other possible drainage points with Ø125 pipes



PERFECT AND STABLE JOINING

The channel end caps are made with male-female connections, with an inner slot that allows for sealing them together. It is advisable to use silicone sealant with neutral cross-linkage and low modulus.



SECURE ANCHORING IN THE CONCRETE

Fixing system designed by GRIDIRON: tang embedded into the concrete with a housing for the nut through which the screw is inserted

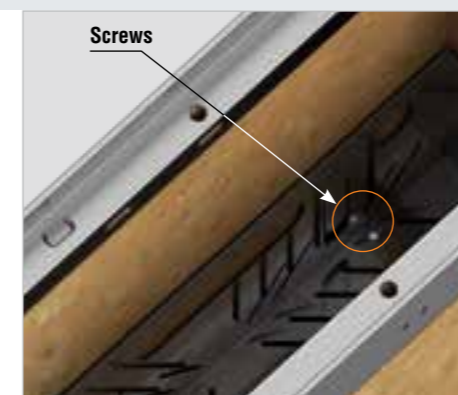

Drainage hole: The only function of the hole on the bottom is to avoid the sump unit filling with water during warehouse storage.

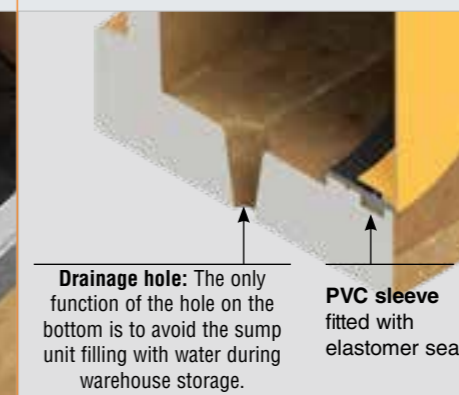

PVC sleeve
fitted with elastomer seal

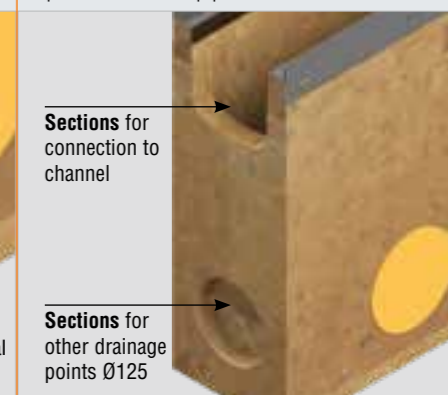

Sections
for connection to channel

Sections
for other drainage points Ø125

POLYMER CONCRETE CHANNELS P 150 SERIES

Grating width 150 mm

Polymer concrete channel with galvanised edge rails. The channels are sold exclusively in complete pallets and together with the gratings.

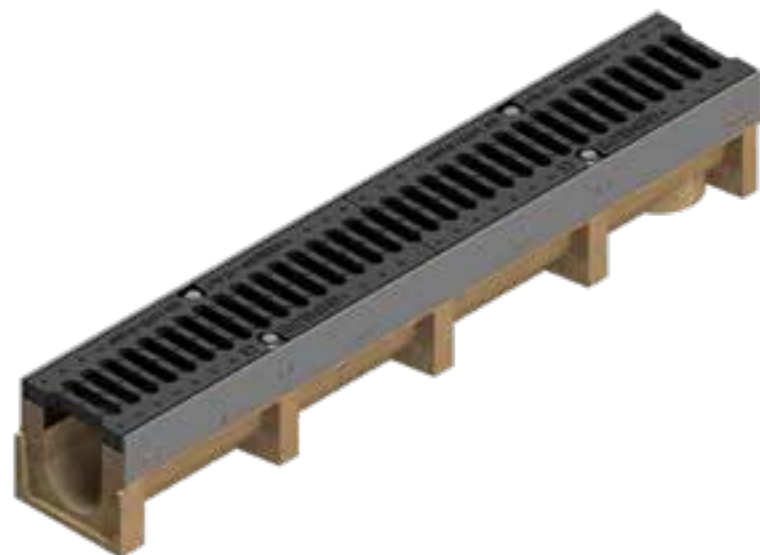

P 150 Series channel dimensions

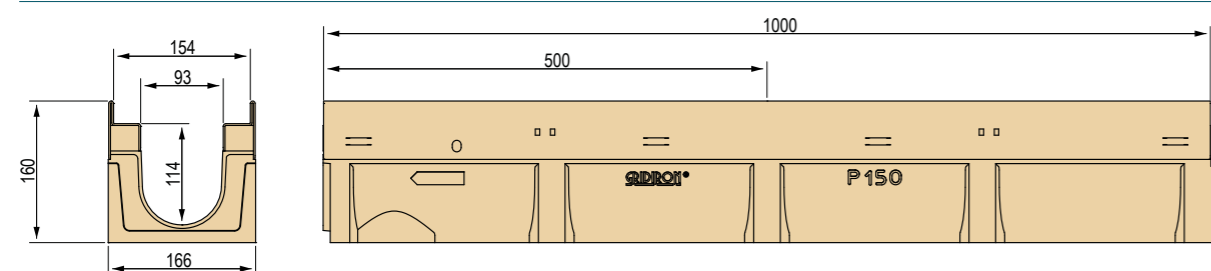

Available gratings

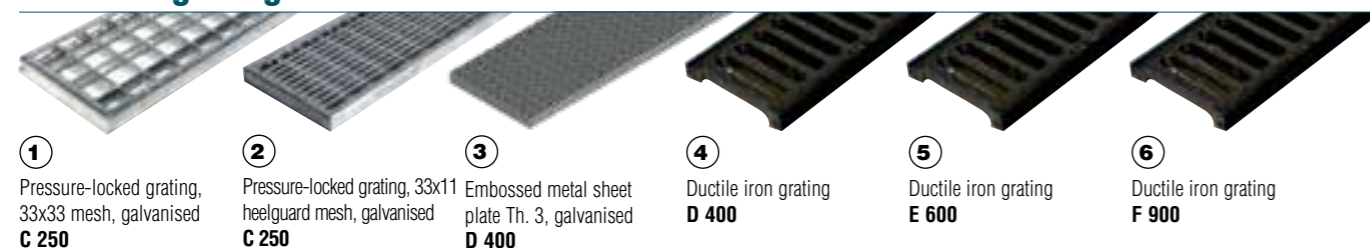

P 150 Series channel complete with grating - Length 1,000 / 500 mm

Channel L mm	Code	Grating	Description of the channel assembled with the grating complete with accessories	Weight kg	Load class
1,000	4RP1SGP	①	Channel complete with pressure-locked grating with C-shaped edges, 25x2-10x2 33x33, hot-dip galvanised	23.82	C 250
	4RP1SGPA	②	Channel complete with pressure-locked grating with C-shaped edges, 25x2-10x2 33x11 heelguard mesh, hot-dip galvanised	24.40	
	4RP1SP	③	Channel complete with embossed metal sheet plate Th. 3, reinforced and hot-dip galvanised	31.00	D 400
	4RP1SGG	④	Channel complete with 2 x GJS500-7 D 400 ductile iron gratings	29.45	
	4RP1SGSE	⑤	Channel complete with 2 x GJS500-7 E 600 ductile iron gratings	29.70	
	4RP1SGSF	⑥	Channel complete with 2 x GJS500-7 F 900 ductile iron gratings	30.36	
500	4RP1MSGP	①	Channel complete with pressure-locked grating with C-shaped edges, 25x2-10x2 33x33, hot-dip galvanised	11.91	C 250
	4RP1MSGA	②	Channel complete with pressure-locked grating with C-shaped edges, 25x2-10x2 33x11 heelguard mesh, hot-dip galvanised	12.20	
	4RP1MSP	③	Channel complete with embossed metal sheet plate Th. 3, reinforced and hot-dip galvanised	15.50	D 400
	4RP1MSGG	④	Channel complete with GJS500-7 D 400 ductile iron grating	14.73	
	4RP1MSGSE	⑤	Channel complete with GJS500-7 E 600 ductile iron grating	14.85	
	4RP1MSGSF	⑥	Channel complete with GJS500-7 F 900 ductile iron grating	15.18	

P 150 Series accessories

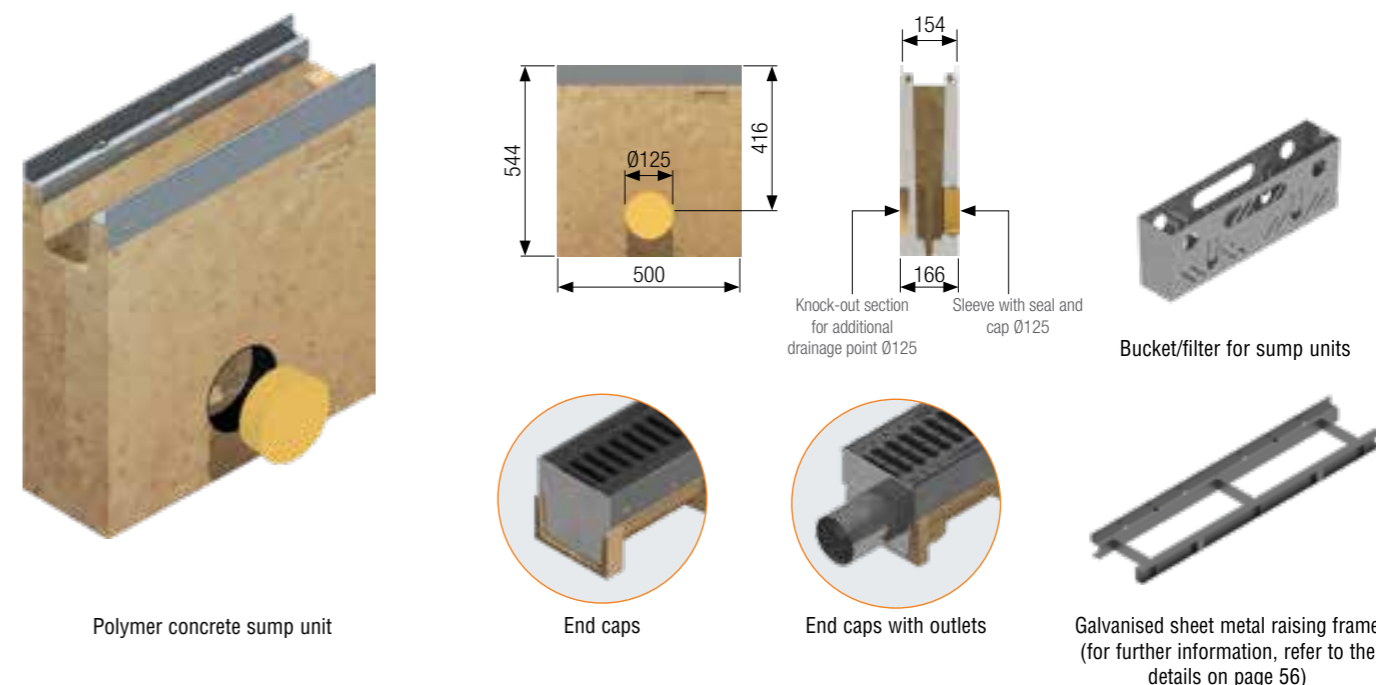

P 150 Series polymer concrete sump unit complete with grating - Length 500 mm

Sump unit L mm	Code	Grating	Description of the sump unit assembled with the grating complete with accessories	Weight kg	Load class
500	4RP1PZGP	①	Sump unit complete with pressure-locked grating with C-shaped edges, 25x2-10x2 33x33, hot-dip galvanised	65.73	C 250
	4RP1PZGPA	②	Sump unit complete with pressure-locked grating with C-shaped edges, 25x2-10x2 33x11 heelguard mesh, hot-dip galvanised	66.37	
	4RP1PZP	③	Sump unit complete with embossed metal sheet plate Th. 3, reinforced and hot-dip galvanised	68.48	D 400
	4RP1PZGS	④	Sump unit complete with GJS500-7 D 400 ductile iron grating	67.40	
	4RP1PZGSE	⑤	Sump unit complete with GJS500-7 E 600 ductile iron grating	69.15	
	4RP1PZGSF	⑥	Sump unit complete with GJS500-7 F 900 ductile iron grating	73.89	

P 150 Series polymer concrete sump unit without grating and accessories

Code	Description	Weight kg
4RP1PZ	Polymer concrete sump unit with galvanised edge rail L=500	65.00
4RP1TID	Right-hand end cap for channel closure female side	1.58
4RP1TIS	Left-hand end cap for channel closure male side	1.58
4RP1RI	End cap with outlet for P150 channel Ø90 mm	1.72
4R01VI	Bucket/filter, AISI 304 stainless steel	1.16
4R01PR	Galvanised sheet metal raising frame for two-stage channel laying	

P 150 Series channel without grating - Length 1,000 / 500 mm

Channel L mm	Code	Description	Water passage mm	Run-off section cm ²	Weight kg
1,000	4RP1S	Additivated polymer concrete P150 channel with galvanised protective edge rails, complying with the UNI EN 1433 standard.	93	95	20.1
500	4RP1MS	Additivated polymer concrete P150 channel with galvanised protective edge rails, complying with the UNI EN 1433 standard.	93	95	10.05

POLYMER CONCRETE CHANNELS P 150 SERIES lowered

Grating width 150 mm

Polymer concrete channel with galvanised edge rails. The channels are sold exclusively in complete pallets and together with the gratings.

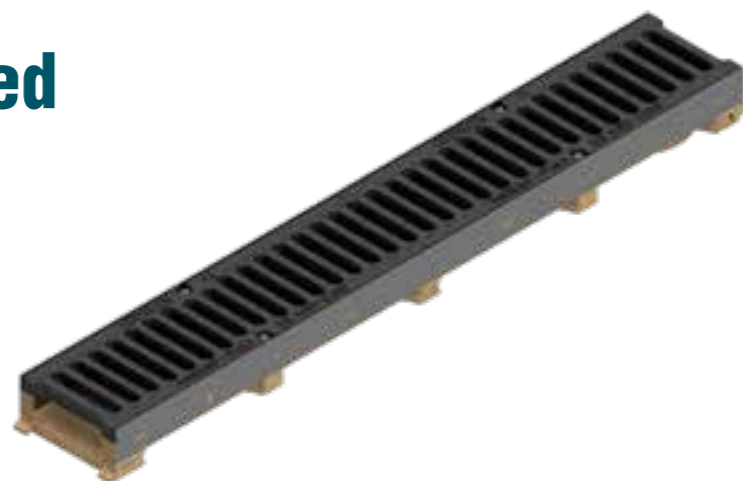

P 150 Series lowered channel dimensions

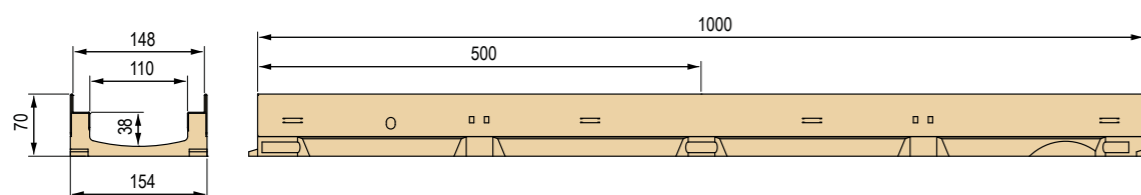

Available gratings N.B.: the gratings in yellow are available only on request

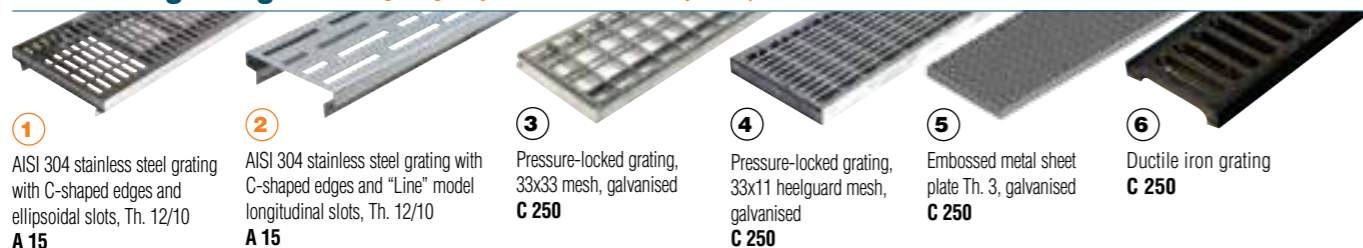

① AISI 304 stainless steel grating with C-shaped edges and ellipsoidal slots, Th. 12/10
A 15

② AISI 304 stainless steel grating with C-shaped edges and "Line" model longitudinal slots, Th. 12/10
A 15

③ Pressure-locked grating, 33x33 mesh, galvanised
C 250

④ Pressure-locked grating, 33x11 heelguard mesh, galvanised
C 250

⑤ Embossed metal sheet plate Th. 3, galvanised
C 250

⑥ Ductile iron grating
C 250

P 150 Series lowered channel complete with grating - Length 1,000 / 500 mm

Channel L mm	Code	Grating	Description of the channel assembled with the grating complete with accessories	Weight kg	Load class
1,000	4RPOS LI	①	Channel complete with self-locking grating made of AISI 304 stainless steel press-formed metal sheet, with C-shaped edges and ellipsoidal slots, Th. 12/10	10.50	A 15
	4RPOS LL I	②	Channel complete with self-locking grating made of AISI 304 stainless steel press-formed metal sheet, with C-shaped edges and "Line" model longitudinal slots, Th. 12/10	9.49	
	4RPOS GP	③	Channel complete with pressure-locked grating with C-shaped edges, 20x2-10x2 33x33, hot-dip galvanised	10.10	C 250
	4RPOS GP A	④	Channel complete with pressure-locked grating with C-shaped edges, 20x2-10x2 33x11 heelguard mesh, hot-dip galvanised	11.25	
	4RPOS P	⑤	Channel complete with embossed metal sheet plate Th. 3, reinforced and hot-dip galvanised	17.21	
	4RPOS GG	⑥	Channel complete with 2 x GJS500-7 ductile iron gratings	17.60	
500	4RPOMS LI	①	Channel complete with self-locking grating made of AISI 304 stainless steel press-formed metal sheet, with C-shaped edges and ellipsoidal slots, Th. 12/10	4.75	A 15
	4RPOMS LL I	②	Channel complete with self-locking grating made of AISI 304 stainless steel press-formed metal sheet, with C-shaped edges and "Line" model longitudinal slots, Th. 12/10	5.53	B 125
	4RPOMS GP	③	Channel complete with pressure-locked grating with C-shaped edges, 20x2-10x2 33x33, hot-dip galvanised	5.05	C 250
	4RPOMS GA	④	Channel complete with pressure-locked grating with C-shaped edges, 20x2-10x2 33x11 heelguard mesh, hot-dip galvanised	5.63	
	4RPOMS P	⑤	Channel complete with embossed metal sheet plate Th. 3, reinforced and hot-dip galvanised	8.61	
	4RPOMS GG	⑥	Channel complete with GJS500-7 ductile iron grating	8.80	

P 150 Series lowered accessories

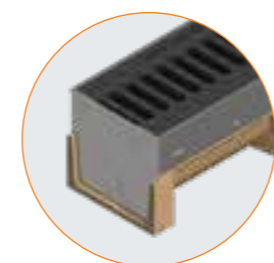

End cap for channel

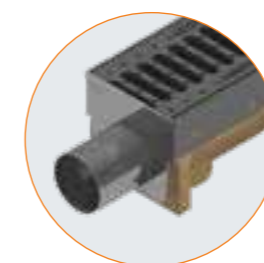

End caps with outlets

Code	Description	Weight kg
4RPOT I	Channel end cap	0.136
4RPOR I	End cap with outlet for P150 lowered channel Ø40 mm	0.244

P 150 Series lowered channel without grating - Length 1,000 / 500 mm

Channel L mm	Code	Description	Water passage mm	Run-off section cm ²	Weight kg	Pieces pallet
1,000	4RPOS	Additivated polymer concrete P150 lowered channel with galvanised protective edge rails, complying with the UNI EN 1433 standard	111	40	7.51	56
1,000	4RPOS I	Additivated polymer concrete P150 lowered channel with AISI 304 stainless steel protective edge rails, complying with the UNI EN 1433 standard	111	40	7.51	56
500	4RPOMS	Additivated polymer concrete P150 lowered channel with galvanised protective edge rails, complying with the UNI EN 1433 standard.	111	40	3.76	loose

POLYMER CONCRETE CHANNELS P 210 SERIES

Grating width 210 mm

Polymer concrete channel with galvanised edge rails. The channels are sold exclusively in complete pallets and together with the gratings.

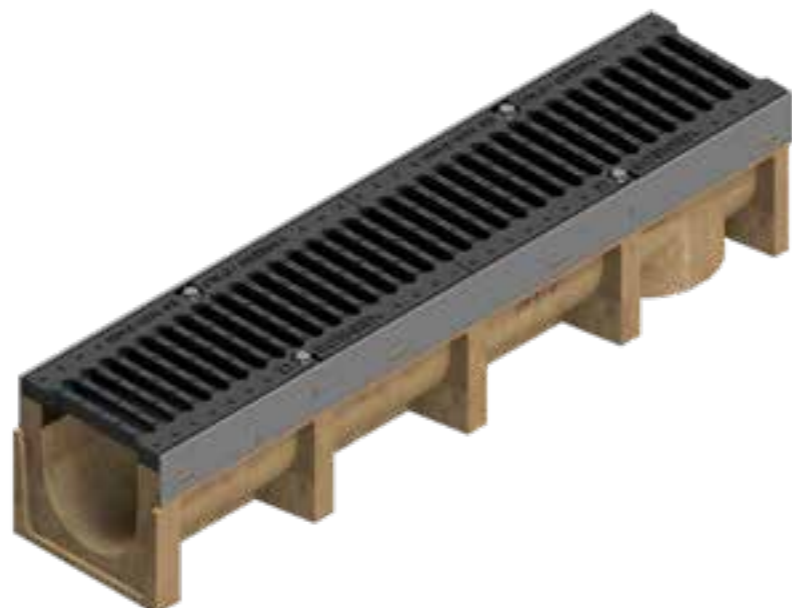

P 210 Series channel dimensions

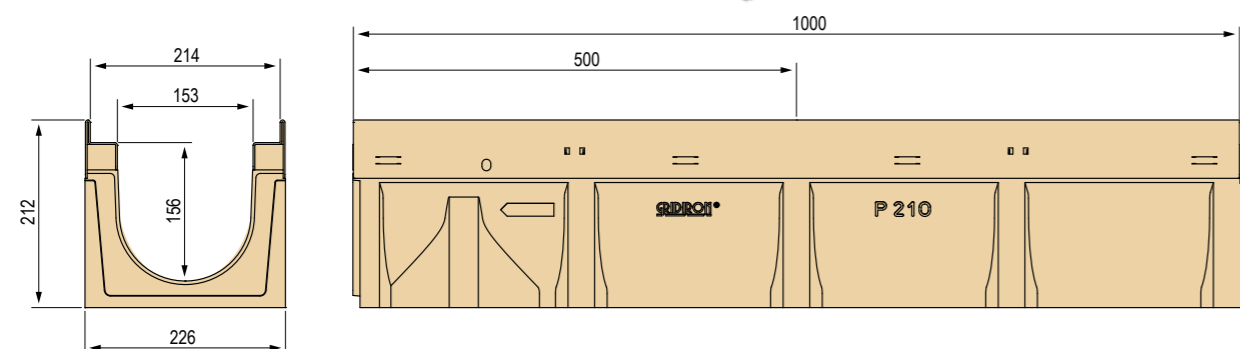

Available gratings

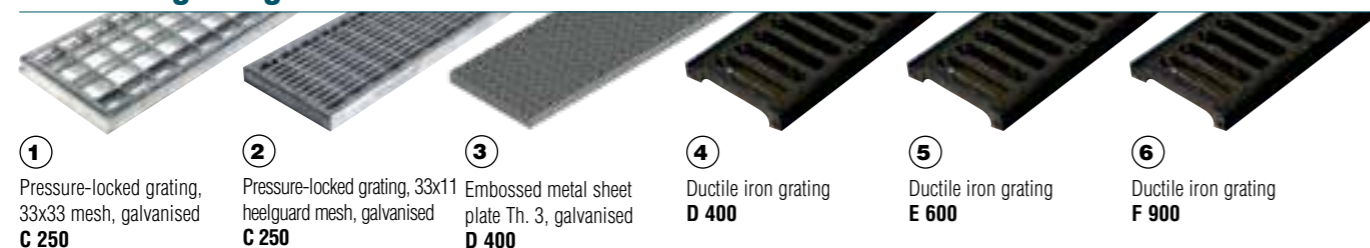

P 210 Series channel complete with grating - Length 1,000 / 500 mm

Channel L mm	Code	Grating	Description of the channel assembled with the grating complete with accessories	Weight kg	Load class
1,000	4RP2SGP	①	Channel complete with pressure-locked grating with C-shaped edges, 25x2-10x2 33x33, hot-dip galvanised	31.20	C 250
	4RP2SGPA	②	Channel complete with pressure-locked grating with C-shaped edges, 25x2-10x2 33x11 heelguard mesh, hot-dip galvanised	31.90	
	4RP2SP	③	Channel complete with embossed metal sheet plate Th. 3, reinforced and hot-dip galvanised	40.82	D 400
	4RP2SGG	④	Channel complete with 2 x GJS500-7 D 400 ductile iron gratings	39.45	
	4RP2SGSE	⑤	Channel complete with 2 x GJS500-7 E 600 ductile iron gratings	42.00	
	4RP2SGSF	⑥	Channel complete with 2 x GJS500-7 F 900 ductile iron gratings	45,74	
500	4RP2MSGP	①	Channel complete with pressure-locked grating with C-shaped edges, 25x2-10x2 33x33, hot-dip galvanised	15.60	C 250
	4RP2MSGA	②	Channel complete with pressure-locked grating with C-shaped edges, 25x2-10x2 33x11 heelguard mesh, hot-dip galvanised	15.95	
	4RP2MSP	③	Channel complete with embossed metal sheet plate Th. 3, reinforced and hot-dip galvanised	20.41	D 400
	4RP2MSGG	④	Channel complete with GJS500-7 D 400 ductile iron grating	19.73	
	4RP2MSGSE	⑤	Channel complete with GJS500-7 E 600 ductile iron grating	21.00	
	4RP2MSGSF	⑥	Channel complete with GJS500-7 F 900 ductile iron grating	22,87	

P 210 Series accessories

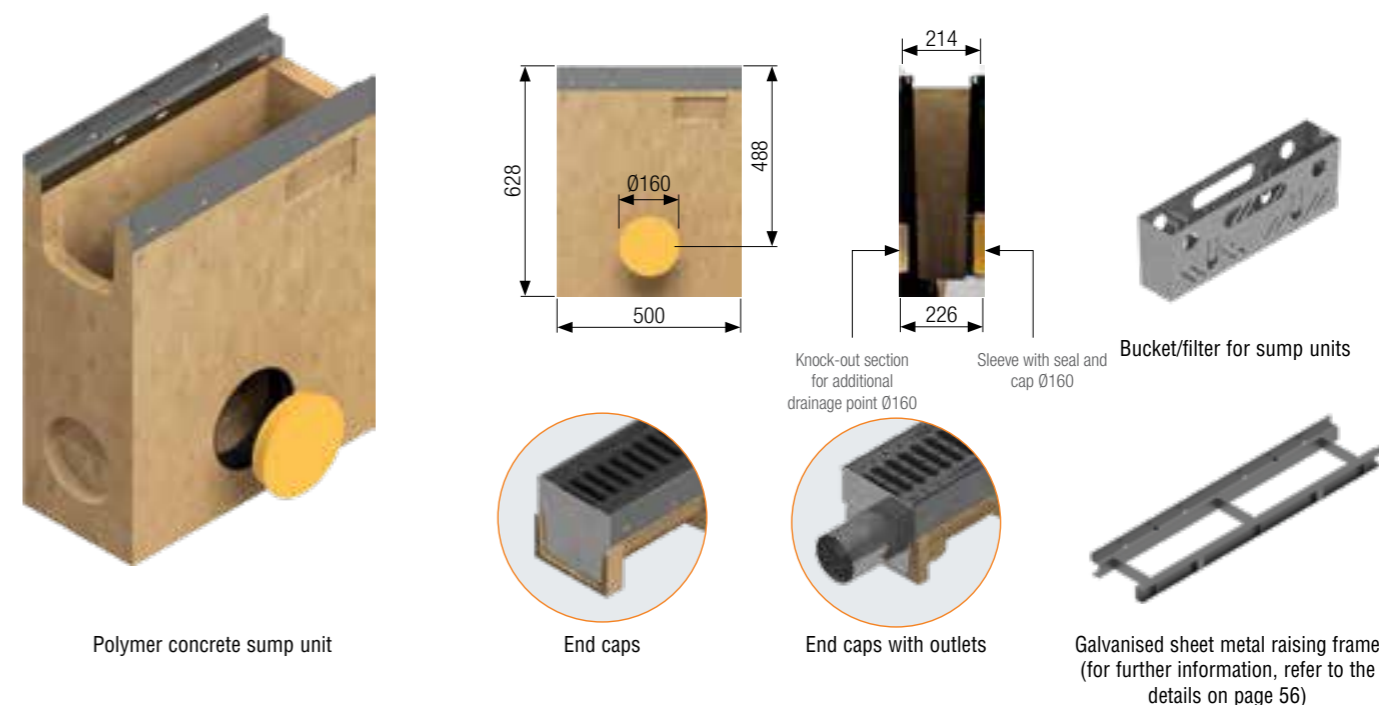

P 210 Series polymer concrete sump unit complete with grating - Length 500 mm

Sump unit L mm	Code	Grating	Description of the sump unit assembled with the grating complete with accessories	Weight kg	Load class
500	4RP2PZGP	①	Sump unit complete with pressure-locked grating with C-shaped edges, 25x2-10x2 33x33, hot-dip galvanised	80.88	C 250
	4RP2PZGPA	②	Sump unit complete with pressure-locked grating with C-shaped edges, 25x2-10x2 33x11 heelguard mesh, hot-dip galvanised	81.83	
	4RP2PZP	③	Sump unit complete with embossed metal sheet plate Th. 3, reinforced and hot-dip galvanised	85.06	D 400
	4RP2PZGS	④	Sump unit complete with GJS500-7 D 400 ductile iron grating	82.85	
	4RP2PZGSE	⑤	Sump unit complete with GJS500-7 E 600 ductile iron grating	86.20	
	4RP2PZGSF	⑥	Sump unit complete with GJS500-7 F 900 ductile iron grating	91,17	

P 210 Series polymer concrete sump unit without grating and accessories

Code	Description	Weight kg
4RP2PZ	Polymer concrete sump unit with galvanised edge rail L=500	79.00
4RP2TID	Right-hand end cap for channel closure female side	0.494
4RP2TIS	Left-hand end cap for channel closure male side	0.516
4RP2RI	End cap with outlet for P210 channel Ø150 mm	0.946
4R02VI	Bucket/filter, AISI 304 stainless steel	1.50
4R02PR	Galvanised sheet metal raising frame for two-stage channel laying	

P 210 Series channel without grating - Length 1,000 / 500 mm

Channel L mm	Code	Description	Water passage mm	Run-off section cm ²	Weight kg	Pieces pallet
1,000	4RP2S	Additivated polymer concrete P210 channel with galvanised protective edge rails, complying with the UNI EN 1433 standard	153	210	26.42	20
500	4RP2MS	Additivated polymer concrete P210 channel with galvanised protective edge rails, complying with the UNI EN 1433 standard	153	210	13.21	loose

POLYMER CONCRETE CHANNELS P 210 SERIES lowered

Grating width 190 mm

Polymer concrete channel with galvanised edge rails. The channels are sold exclusively in complete pallets and together with the gratings.



P 210 Series lowered channel dimensions

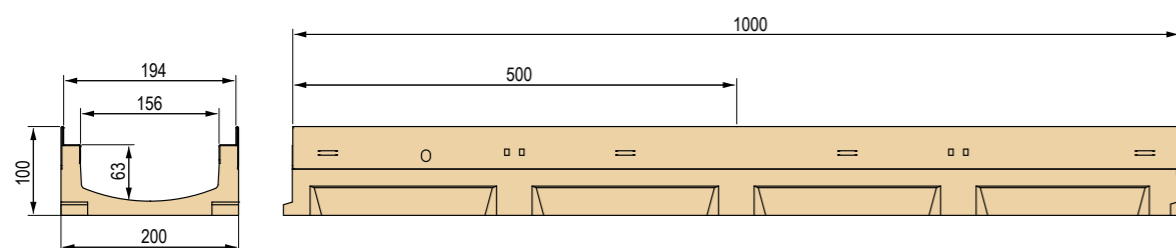

Available gratings *N.B.: the gratings in yellow are available only on request*



① AISI 304 stainless steel grating with C-shaped edges and ellipsoidal slots, Th. 12/10
A 15

② Pressure-locked grating, 55x11 heelguard mesh, galvanised
B 125

③ Pressure-locked grating, 33x33 mesh, galvanised
C 250

④ Pressure-locked grating, 33x11 heelguard mesh, galvanised
C 250

⑤ Embossed metal sheet plate Th. 3, galvanised
C 250

P 210 Series lowered channel complete with grating - Length 1,000 / 500 mm

Channel L mm	Code	Grating	Description of the channel assembled with the grating complete with accessories	Weight kg	Load class
1,000	4RP6SLI	①	Channel complete with self-locking grating made of AISI 304 stainless steel press-formed metal sheet, with C-shaped edges and ellipsoidal slots, Th. 12/10	16.25	A 15
	4RP6SGPB	②	Channel complete with pressure-locked grating with C-shaped edges, 20x2-10x2 55x11 heelguard mesh, hot-dip galvanised	17.52	B 125
	4RP6SGP	③	Channel complete with pressure-locked grating with C-shaped edges, 20x2-10x2 33x33, hot-dip galvanised	16.46	C 250
	4RP6SGPA	④	Channel complete with pressure-locked grating with C-shaped edges, 20x2-10x2 33x11 heelguard mesh, hot-dip galvanised	18.36	
	4RP6SP	⑤	Channel complete with embossed metal sheet plate Th. 3, reinforced and hot-dip galvanised	27.30	
500	4RP6MSLI	①	Channel complete with self-locking grating made of AISI 304 stainless steel press-formed metal sheet, with C-shaped edges and ellipsoidal slots, Th. 12/10	8.10	A 15
	4RP6MSGB	②	Channel complete with pressure-locked grating with C-shaped edges, 20x2-10x2 55x11 heelguard mesh, hot-dip galvanised	8.76	B 125
	4RP6MSGP	③	Channel complete with pressure-locked grating with C-shaped edges, 20x2-10x2 33x33, hot-dip galvanised	8.23	C 250
	4RP6MSGA	④	Channel complete with pressure-locked grating with C-shaped edges, 20x2-10x2 33x11 heelguard mesh, hot-dip galvanised	9.18	
	4RP6MSP	⑤	Channel complete with embossed metal sheet plate Th. 3, reinforced and hot-dip galvanised	13.65	



P 210 Series lowered accessories

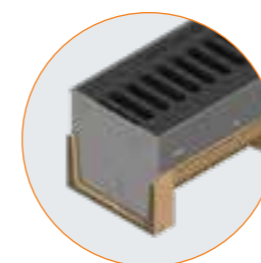

End cap for channel

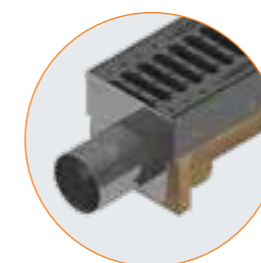

End caps with outlets

Code	Description	Weight kg
4RP6TI	Channel end cap	0.24
4RP6RI	End cap with outlet for P210 lowered channel Ø75 mm	0.372

P 210 Series lowered channel without grating - Length 1,000 / 500 mm

Channel L mm	Code	Description	Water passage mm	Run-off section cm ²	Weight kg	Pieces pallet
1,000	4RP6S	Additivated polymer concrete P210 lowered channel with galvanised protective edge rails, complying with the UNI EN 1433 standard	156	89	12.9	30
	4RP6SI	Additivated polymer concrete P210 lowered channel with AISI 304 stainless steel protective edge rails, complying with the UNI EN 1433 standard	156	89	12.9	30
500	4RP6MS	Additivated polymer concrete P210 lowered channel with galvanised protective edge rails, complying with the UNI EN 1433 standard	156	89	6.5	loose

POLYMER CONCRETE CHANNELS P 265 SERIES

Grating width 265 mm

Polymer concrete channel with galvanised protective edge rails. The channels are sold exclusively in complete pallets and together with the gratings.

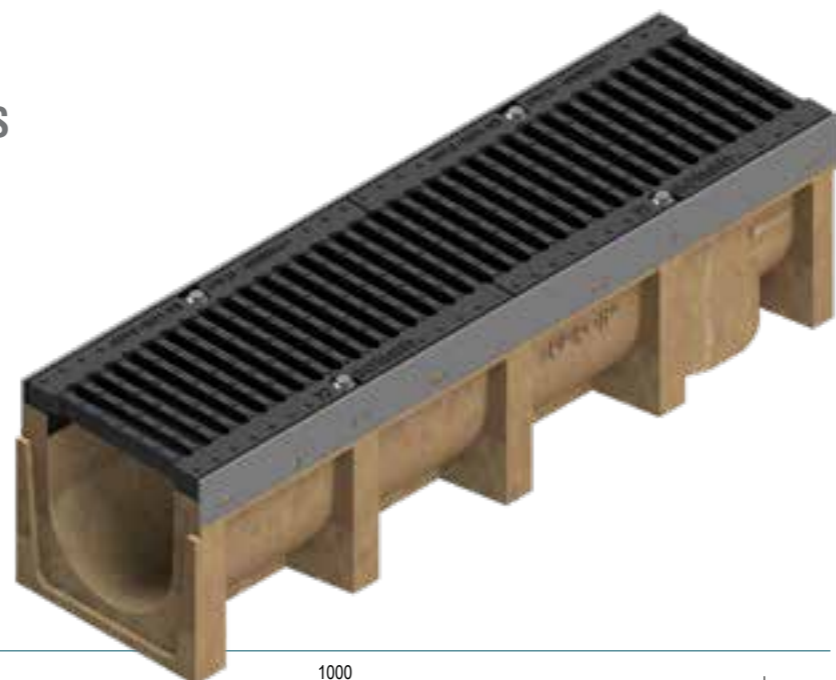

P 265 Series channel dimensions

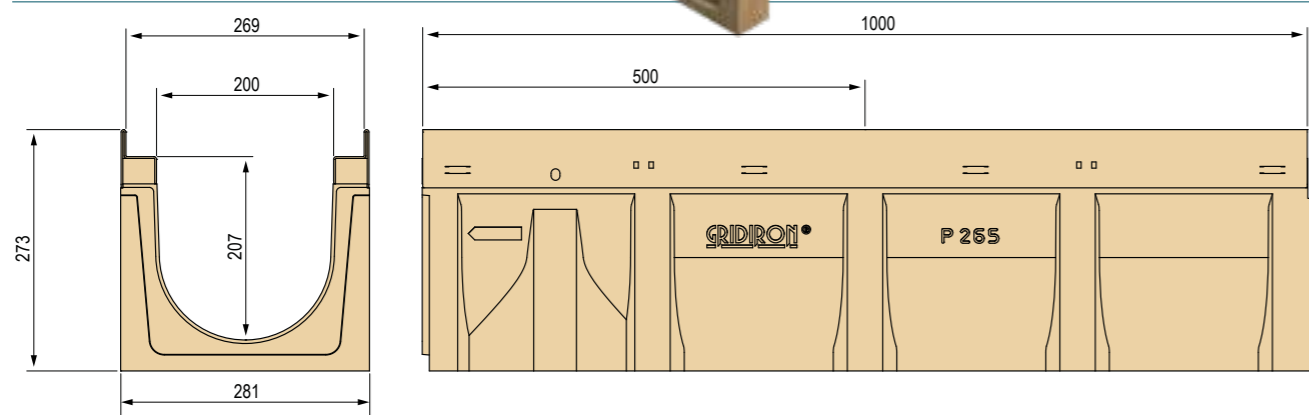

Available gratings

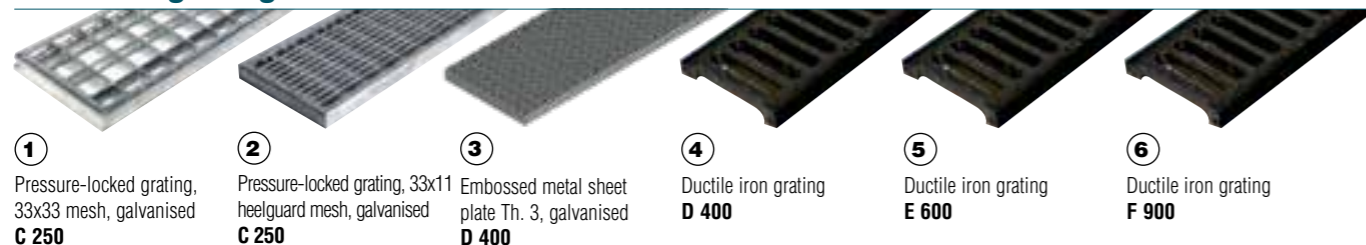

- ① Pressure-locked grating, 33x33 mesh, galvanised **C 250**
- ② Pressure-locked grating, 33x11 heelguard mesh, galvanised **C 250**
- ③ Embossed metal sheet plate Th. 3, galvanised **D 400**
- ④ Ductile iron grating **D 400**
- ⑤ Ductile iron grating **E 600**
- ⑥ Ductile iron grating **F 900**

P 265 Series channel complete with grating - Length 1,000 / 500 mm

Channel L mm	Code	Grating	Description of the channel assembled with the grating complete with accessories	Weight kg	Load class
1,000	4RP3SGP	①	Channel complete with pressure-locked grating 30x3-10x2 33x33, hot-dip galvanised	51.85	C 250
	4RP3SGPA	②	Channel complete with pressure-locked grating 30x3-10x2 33x15 heelguard mesh, hot-dip galvanised	53.30	
	4RP3SP	③	Channel complete with embossed metal sheet plate Th. 3, reinforced and hot-dip galvanised	62.54	D 400
	4RP3SGG	④	Channel complete with 2 x GJS500-7 D 400 ductile iron gratings	59.30	
	4RP3SGSE	⑤	Channel complete with 2 x GJS500-7 E 600 ductile iron gratings	65.70	
	4RP3SGSF	⑥	Channel complete with 2 x GJS500-7 F 900 ductile iron gratings	69.32	
500	4RP3MSGP	①	Channel complete with pressure-locked grating 30x3-10x2 33x33, hot-dip galvanised	25.93	C 250
	4RP3MSGA	②	Channel complete with pressure-locked grating 30x3-10x2 33x15 heelguard mesh, hot-dip galvanised	26.65	
	4RP3MSP	③	Channel complete with embossed metal sheet plate Th. 3, reinforced and hot-dip galvanised	31.27	D 400
	4RP3MSGG	④	Channel complete with GJS500-7 D 400 ductile iron grating	29.65	
	4RP3MSGSE	⑤	Channel complete with GJS500-7 E 600 ductile iron grating	32.85	
	4RP3MSGSF	⑥	Channel complete with GJS500-7 F 900 ductile iron grating	34.66	

P 265 Series accessories

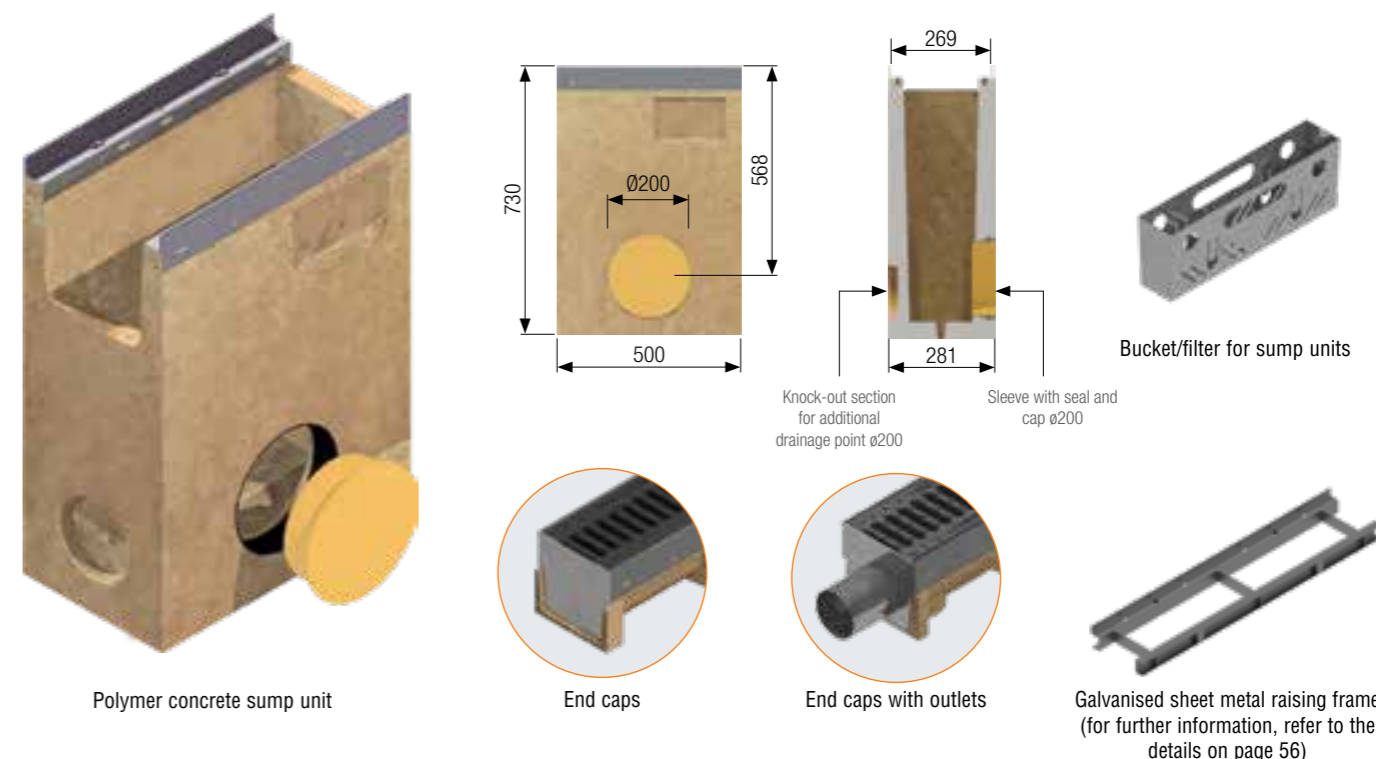

P 265 Series polymer concrete sump unit complete with grating - Length 500 mm

Sump unit L mm	Code	Grating	Description of the sump unit assembled with the grating complete with accessories	Weight kg	Load class
500	4RP3PZGP	①	Sump unit complete with pressure-locked grating 30x3-10x2 33x33, hot-dip galvanised	110.75	C 250
	4RP3PZGPA	②	Sump unit complete with pressure-locked grating 30x3-10x2 33x15 heelguard mesh, hot-dip galvanised	111.50	
	4RP3PZP	③	Sump unit complete with embossed metal sheet plate Th. 3, reinforced and hot-dip galvanised	114.70	D 400
	4RP3PZGS	④	Sump unit complete with GJS500-7 D 400 ductile iron grating	111.45	
	4RP3PZGSE	⑤	Sump unit complete with GJS500-7 E 600 ductile iron grating	117.86	
	4RP3PZGSF	⑥	Sump unit complete with GJS500-7 F 900 ductile iron grating	121.43	

P 265 Series polymer concrete sump unit without grating and accessories

Code	Description	Weight kg
4RP3PZ	Polymer concrete sump unit with galvanised edge rail L=500	106.00
4RP3TID	Right-hand end cap for channel closure female side	0.752
4RP3TIS	Left-hand end cap for channel closure male side	0.774
4RP3RI	End cap with outlet for P265 channel Ø160 mm	1.398
4R03VI	Bucket/filter, AISI 304 stainless steel	1.71
4R03PR	Galvanised sheet metal raising frame for two-stage channel laying	

P 265 Series channel without grating - Length 1,000 / 500 mm

Channel L mm	Code	Description	Water passage mm	Run-off section cm²	Weight kg	Pieces pallet
1,000	4RP3S	Additivated polymer concrete P265 channel with galvanised protective edge rails, complying with the UNI EN 1433 standard.	200	365	43.3	16
500	4RP3MS	Additivated polymer concrete P265 channel with galvanised protective edge rails, complying with the UNI EN 1433 standard.	200	365	21.65	loose

POLYMER CONCRETE CHANNELS P 315 SERIES

Grating width 315 mm

Polymer concrete channel with galvanised protective edge rails. The channels are sold exclusively in complete pallets and together with the gratings.

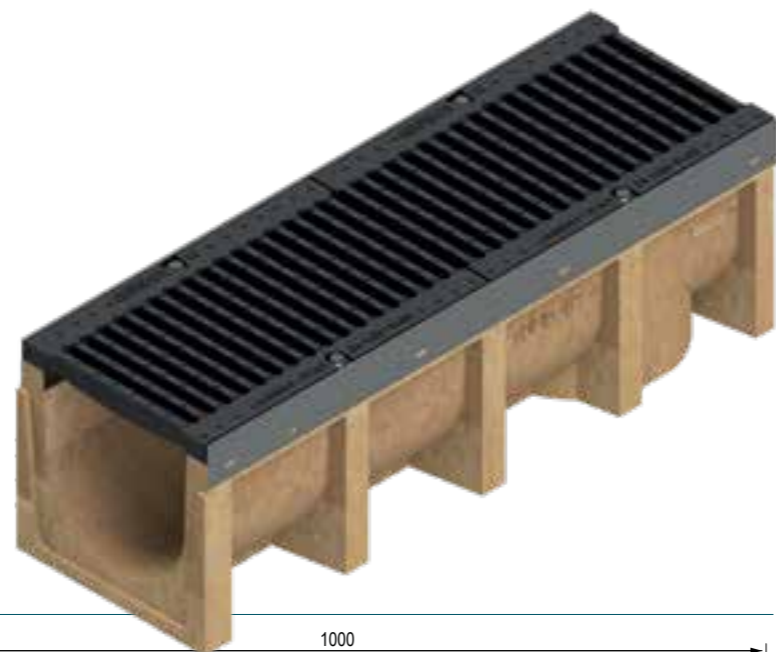

P 315 Series channel dimensions

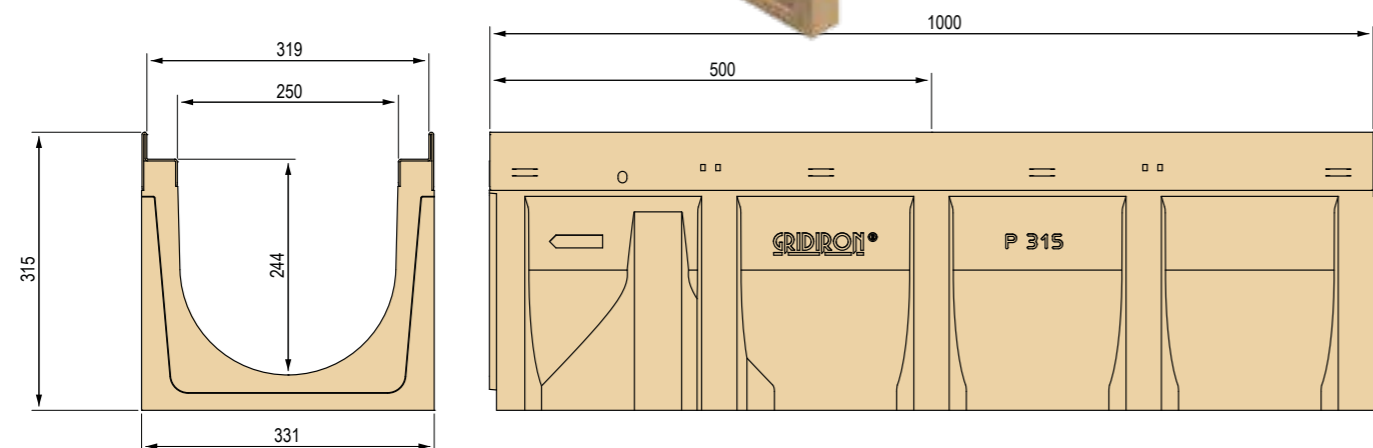

Available gratings

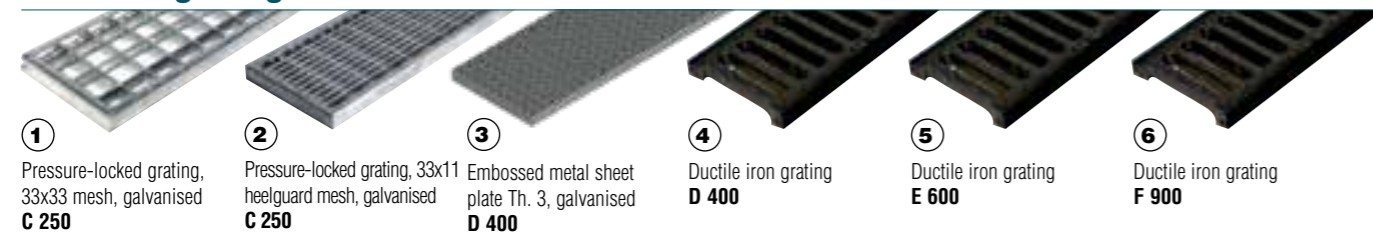

P 315 Series channel complete with grating - Length 1,000 / 500 mm

Channel L mm	Code	Grating	Description of the channel assembled with the grating complete with accessories	Weight kg	Load class
1,000	4RP4SGP	①	Channel complete with pressure-locked grating 30x4-10x2 33x33, hot-dip galvanised	63.07	C 250
	4RP4SGPA	②	Channel complete with pressure-locked grating 30x4-10x2 33x15 heelguard mesh, hot-dip galvanised	64.99	
	4RP4SP	③	Channel complete with embossed metal sheet plate Th. 3, reinforced and hot-dip galvanised	79.58	D 400
	4RP4SGG	④	Channel complete with 2 x GJS500-7 D 400 ductile iron gratings	84,00	
	4RP4SGE	⑤	Channel complete with 2 x GJS500-7 E 600 ductile iron gratings	85,86	
	4RP4SGF	⑥	Channel complete with 2 x GJS500-7 F 900 ductile iron gratings	92,56	
500	4RP4MSGP	①	Channel complete with pressure-locked grating 30x4-10x2 33x33, hot-dip galvanised	31.54	C 250
	4RP4MSGA	②	Channel complete with pressure-locked grating 30x4-10x2 33x15 heelguard mesh, hot-dip galvanised	32.50	
	4RP4MSP	③	Channel complete with embossed metal sheet plate Th. 3, reinforced and hot-dip galvanised	39.79	D 400
	4RP4MSGG	④	Channel complete with GJS500-7 D 400 ductile iron grating	42,20	
	4RP4MSGE	⑤	Channel complete with GJS500-7 E 600 ductile iron grating	42,93	
	4RP4MSGF	⑥	Channel complete with GJS500-7 F 900 ductile iron grating	46,28	



P 315 Series accessories

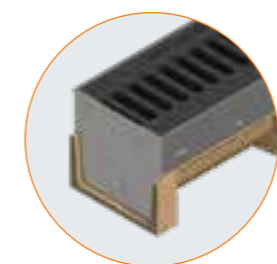

End cap for channel

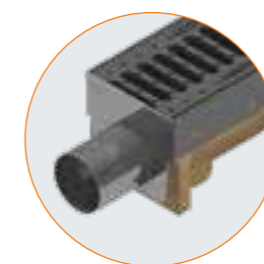

End caps with outlets

Code	Description	Weight kg
4RP4TID	Right-hand end cap for channel closure female side	1.34
4RP4TIS	Left-hand end cap for channel closure male side	1.50
4RP4RI	End cap with outlet for P315 channel Ø204 mm	1.80
4R04PR	Galvanised sheet metal raising frame for two-stage channel laying	

P 315 Series channel without grating - Length 1,000 / 500 mm

Channel L mm	Code	Description	Water passage mm	Run-off section cm ²	Weight kg	Pieces pallet
1,000	4RP4S	Additivated polymer concrete P315 channel with galvanised protective edge rails, complying with the UNI EN 1433 standard.	250	536	50.44	9
500	4RP4MS	Additivated polymer concrete P315 channel with galvanised protective edge rails, complying with the UNI EN 1433 standard.	250	536	25.22	loose

POLYMER CONCRETE CHANNELS P 365 SERIES

Grating width 365 mm

Polymer concrete channel with galvanised protective edge rails.
The channels are sold exclusively in complete pallets and together with the gratings.

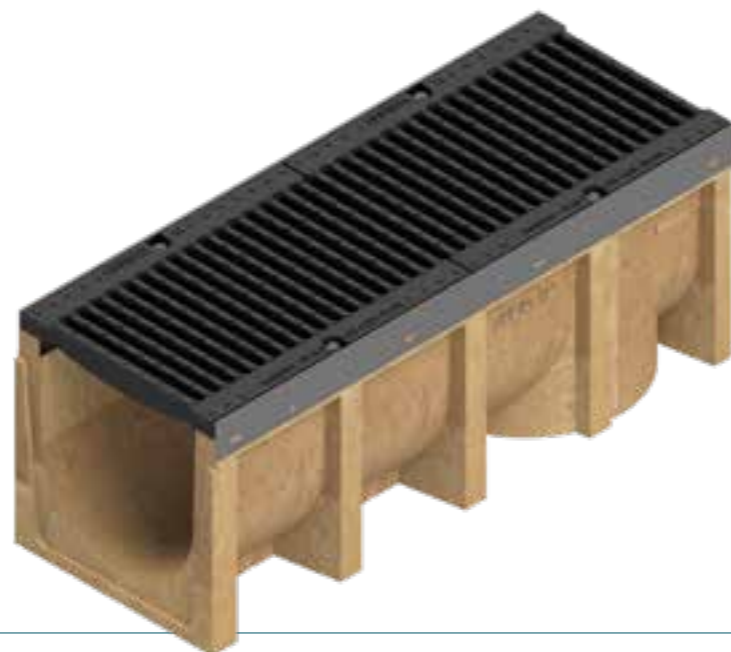

P 365 Series channel dimensions

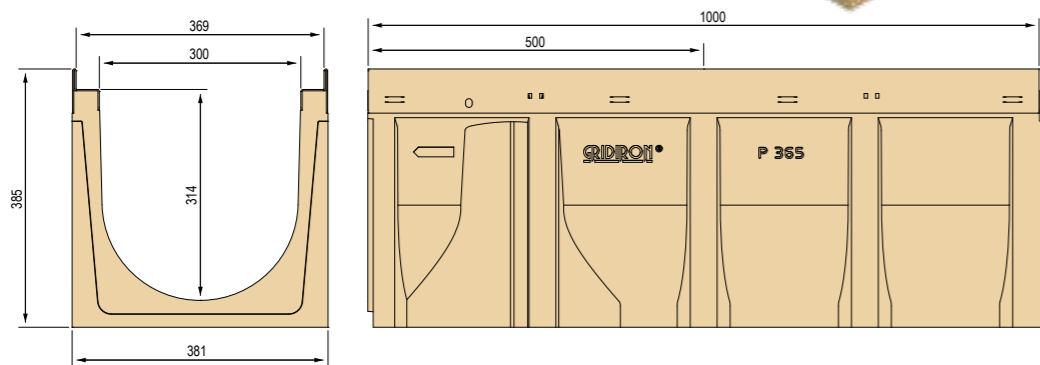

Available gratings N.B.: the gratings in yellow are available only on request



- ① Pressure-locked grating, 33x33 mesh, galvanised **C 250**
- ② Pressure-locked grating, 33x15 heelguard mesh, galvanised **C 250**
- ③ Pressure-locked grating, 22x66 mesh, galvanised **D 400**
- ④ Pressure-locked grating, 15x66 heelguard mesh, galvanised **D 400**
- ⑤ Embossed metal sheet plate Th. 3, galvanised **D 400**
- ⑥ Ductile iron grating **D 400**
- ⑦ Ductile iron grating **E 600**
- ⑧ Ductile iron grating **F 900**

P 365 Series channel complete with grating - Length 1,000 / 500 mm

Channel L mm	Code	Grating	Description of the channel assembled with the grating complete with accessories	Weight kg	Load class
1,000	4RP5SGP	①	Channel complete with pressure-locked grating 30x5-10x3 33x33, hot-dip galvanised	80.32	C 250
	4RP5SGPB	②	Channel complete with pressure-locked grating 30x5-10x3 33x15 heelguard mesh, hot-dip galvanised	84.52	
	4RP5SGPC	③	Channel complete with pressure-locked grating 30x5-10x3 22x66, hot-dip galvanised	85.42	D 400
	4RP5SGPA	④	Channel complete with pressure-locked grating 30x4-10x3 15x66 heelguard mesh, hot-dip galvanised	87.52	
	4RP5SP	⑤	Channel complete with embossed metal sheet plate Th. 3, reinforced and hot-dip galvanised	96.36	
	4RP5SGG	⑥	Channel complete with 2 x GJS500-7 D400 ductile iron gratings	102.26	
	4RP5SGE	⑦	Channel complete with 2 x GJS500-7 E600 ductile iron gratings	109.33	E 600
	4RP5SGF	⑧	Channel complete with 2 x GJS500-7 F 900 ductile iron gratings	113.25	F 900
500	4RP5MSGP	①	Channel complete with pressure-locked grating 30x5-10x3 33x33, hot-dip galvanised	40.16	C 250
	4RP5MSGB	②	Channel complete with pressure-locked grating 30x5-10x3 33x15 heelguard mesh, hot-dip galvanised	42.26	
	4RP5MSGC	③	Channel complete with pressure-locked grating 30x5-10x3 22x66, hot-dip galvanised	42.71	D 400
	4RP5MSGA	④	Channel complete with pressure-locked grating 30x4-10x3 15x66 heelguard mesh, hot-dip galvanised	43.76	
	4RP5MSP	⑤	Channel complete with embossed metal sheet plate Th. 3, reinforced and hot-dip galvanised	48.18	
	4RP5MSGG	⑥	Channel complete with GJS500-7 D400 ductile iron grating	51.13	
	4RP5MSGE	⑦	Channel complete with GJS500-7 E600 ductile iron grating	54.67	E 600
	4RP5MSGF	⑧	Channel complete with GJS500-7 F 900 ductile iron grating	56.63	F 900

P 365 Series accessories

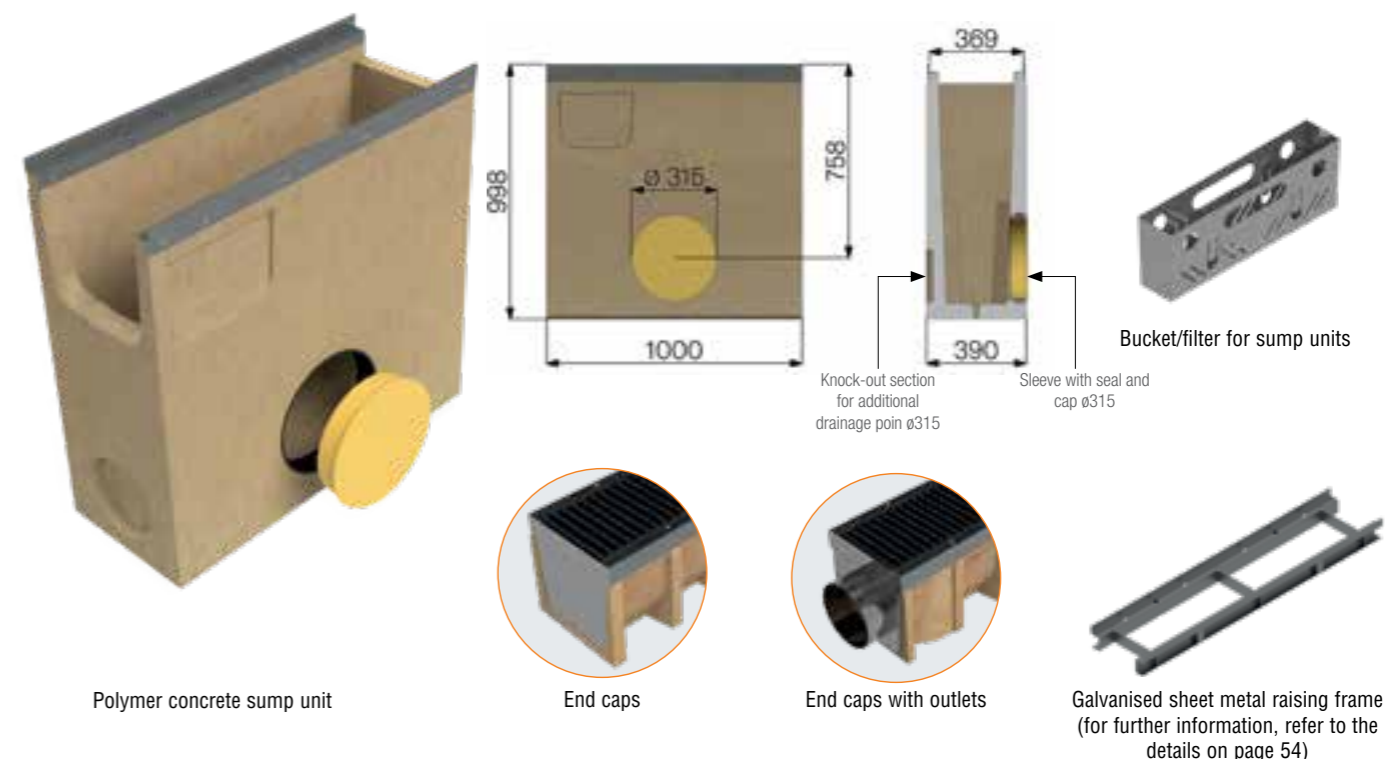

P 365 Series polymer concrete sump unit complete with grating - Length 1000 mm

Sump unit L mm	Code	Grating	Description of the sump unit assembled with the grating complete with accessories	Weight kg	Load class
1000	4RP5PZGS	①	Sump unit complete with GJS500-7 D 400 ductile iron grating	382,74	D 400
	4RP5PZGE	②	Sump unit complete with GJS500-7 E 600 ductile iron grating	389,80	E 600
	4RP5PZGF	③	Sump unit complete with GJS500-7 F 900 ductile iron grating	393,72	F 900

P 365 Series polymer concrete sump unit without grating and accessories

Code	Description	Weight kg
4RP5PZ	Polymer concrete sump unit with galvanised edge rail L=1000	341,00
4RP5TID	Right-hand end cap for channel closure female side	2,90
4RP5TIS	Left-hand end cap for channel closure male side	3,10
4RP5RI	End cap with outlet for P365 Ø250mm	3,10
4R05VI	Bucket/filter, AISI 304 stainless steel	4,14

P 365 Series channel without grating - Length 1,000 / 500 mm

Channel L mm	Code	Description	Water passage mm	Run-off section cm ²	Weight kg	Pieces pallet
1,000	4RP5S	Additivated polymer concrete P365 channel with galvanised protective edge rails, complying with the UNI EN 1433 standard.	300	833	60.52	9
500	4RP5MS	Additivated polymer concrete P365 channel with galvanised protective edge rails, complying with the UNI EN 1433 standard.	300	833	31.28	loose

POLYMER CONCRETE CHANNELS P 150 SERIES WITH DUCTILE IRON EDGE RAIL

Grating width 150 mm

Polymer concrete channel with ductile iron edge rails.
The channels are sold exclusively in complete pallets and together with the gratings.



P 150 Series channel with ductile iron edge rail dimensions

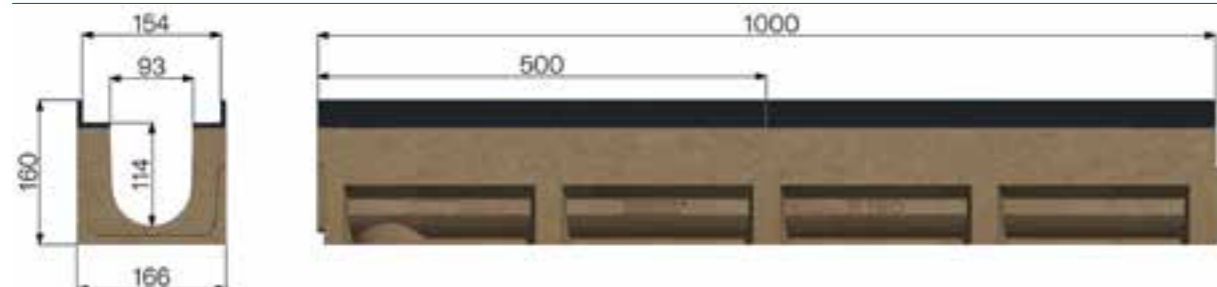

Available gratings



① Ductile iron grating
D 400

② Ductile iron grating
E 600

③ Ductile iron grating
F 900

P 150 Series channel with ductile iron edge rail complete with grating - Length 1000 / 500 mm

Channel L mm	Code	Grating	Description of the channel assembled with the grating complete with accessories	Weight kg	Load class
1000	4PG1SGS	①	Channel complete with 2 x GJS500-7 D 400 ductile iron gratings	32,34	D 400
	4PG1SGE	②	Channel complete with 2 x GJS500-7 E 600 ductile iron gratings	32,58	E 600
	4PG1SGF	③	Channel complete with 2 x GJS500-7 F 900 ductile iron gratings	34,36	F 900
500	4PG1MSGS	①	Channel complete with GJS500-7 D 400 ductile iron gratings	16,17	D 400
	4PG1MSGE	②	Channel complete with GJS500-7 E 600 ductile iron gratings	16,29	E 600
	4PG1MSGF	③	Channel complete with GJS500-7 F 900 ductile iron gratings	17,18	F 900

P 150 Series accessories with ductile iron edge rail

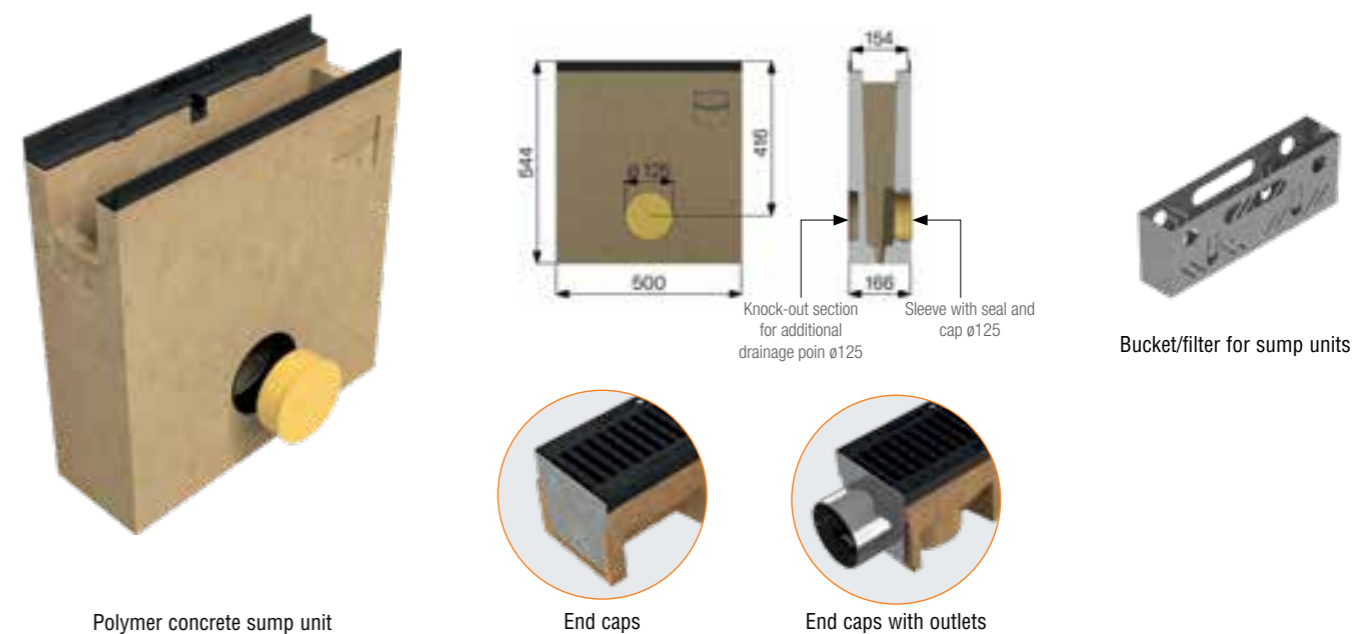

Polymer concrete sump unit

End caps

End caps with outlets

P 150 Series polymer concrete sump unit complete with ductile iron edge rail with grating and accessories - Length 500 mm

Sump unit L mm	Code	Grating	Description of the sump unit assembled with the grating complete with accessories	Weight kg	Load class
500	4PG1PZGS	①	Sump unit complete with GJS500-7 D 400 ductile iron grating	69,40	D 400
	4PG1PZGE	②	Sump unit complete with GJS500-7 E 600 ductile iron grating	71,15	E 600
	4PG1PZGF	③	Sump unit complete with GJS500-7 F 900 ductile iron grating	75,89	F 900

P 150 Series polymer concrete sump unit without ductile iron edge rail with grating and accessories

Code	Description	Weight kg
4PG1PZ	Polymer concrete sump unit with ductile iron edge rail L=500	67,00
4RP1TID	Right-hand end cap for channel closure female side	1,58
4RP1TIS	Left-hand end cap for channel closure male side	1,58
4RP1RI	End cap with outlet for P150 Ø90 mm	1,72
4R01VI	Bucket/filter, AISI 304 stainless steel	1,16

P 150 Series channel with ductile iron edge rail without grating - Length 1000 / 500 mm

Channel L mm	Code	Description	Water passage mm	Run-off section cm ²	Weight kg	Pieces pallet
1000	4PG1S	Additivated polymer concrete P150 channel with ductile iron edge rails, complying with the UNI EN 1433 standard.	93	95	24,00	36
500	4PG1MS	Additivated polymer concrete P150 channel with ductile iron edge rails, complying with the UNI EN 1433 standard.	93	95	12,00	loose

POLYMER CONCRETE CHANNELS P 210 SERIES WITH DUCTILE IRON EDGE RAIL

Grating width 210 mm

Polymer concrete channel with ductile iron edge rails.
The channels are sold exclusively in complete pallets and together with the gratings.



P 210 Series channel with ductile iron edge rail dimensions

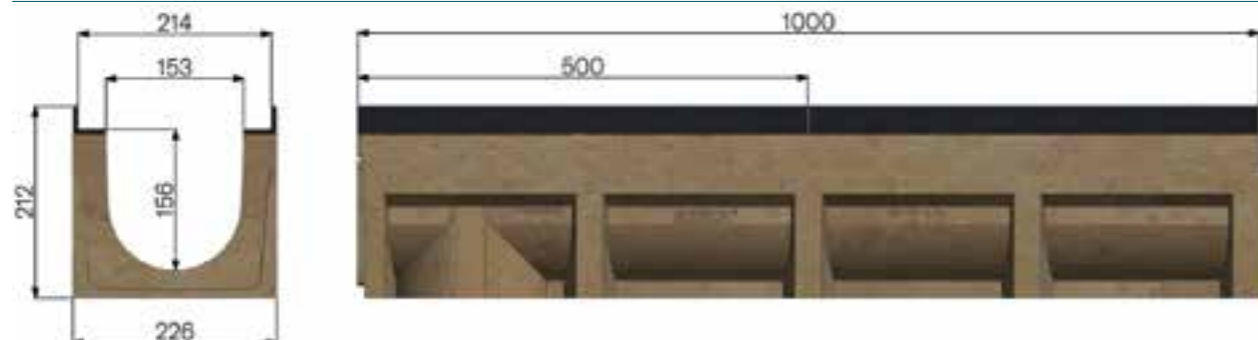

Available gratings



P 210 Series channel with ductile iron edge rail complete with grating - Length 1000 / 500 mm

Channel L mm	Code	Grating	Description of the channel assembled with the grating complete with accessories	Weight kg	Load class
1000	4PG2SGS	①	Channel complete with 2 x GJS500-7 D 400 ductile iron gratings	42,62	D 400
	4PG2SGE	②	Channel complete with 2 x GJS500-7 E 600 ductile iron gratings	45,18	E 600
	4PG2SGF	③	Channel complete with 2 x GJS500-7 F 900 ductile iron gratings	49,74	F 900
500	4PG2MSGS	①	Channel complete with GJS500-7 D 400 ductile iron gratings	21,31	D 400
	4PG2MSGE	②	Channel complete with GJS500-7 E 600 ductile iron gratings	22,59	E 600
	4PG2MSGF	③	Channel complete with GJS500-7 F 900 ductile iron gratings	24,87	F 900

P 210 Series accessories with ductile iron edge rail

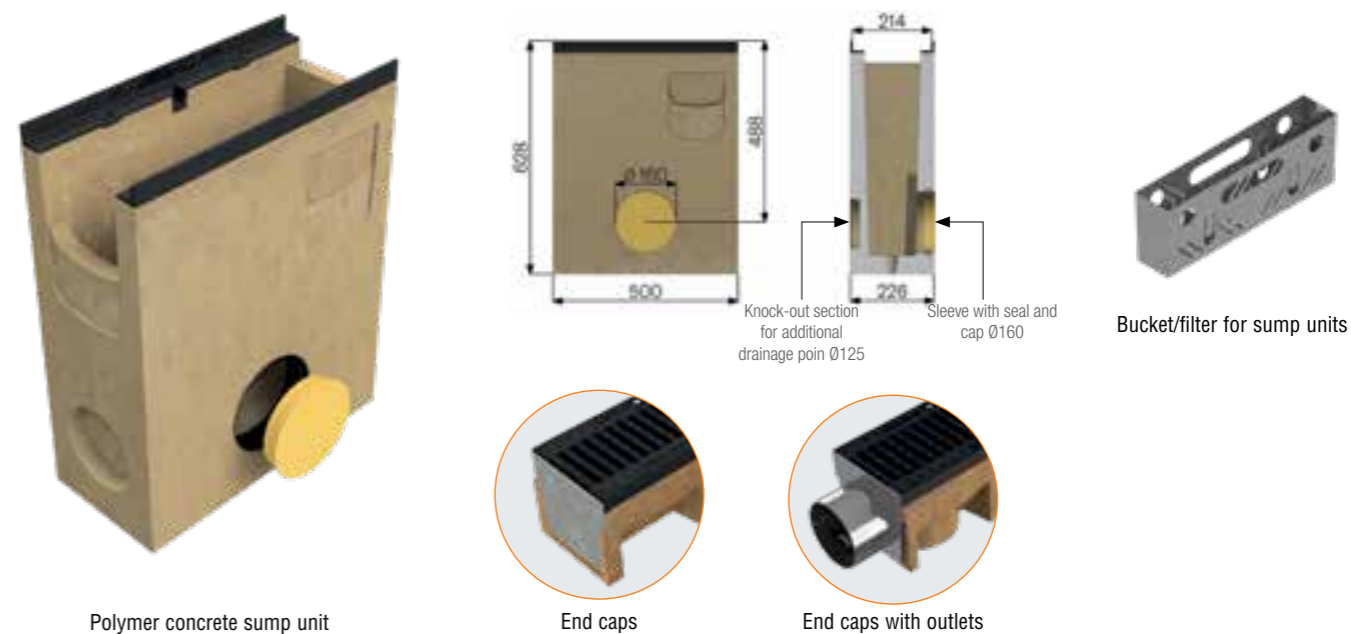

P 210 Series polymer concrete sump unit complete with ductile iron edge rail with grating and accessories - Length 500 mm

Sump unit L mm	Code	Grating	Description of the sump unit assembled with the grating complete with accessories	Weight kg	Load class
500	4PG2PZGS	①	Sump unit complete with GJS500-7 D 400 ductile iron grating	84,85	D 400
	4PG2PZGE	②	Sump unit complete with GJS500-7 E 600 ductile iron grating	88,20	E 600
	4PG2PZGF	③	Sump unit complete with GJS500-7 F 900 ductile iron grating	93,17	F 900

P 210 Series polymer concrete sump unit without ductile iron edge rail with grating and accessories

Code	Description	Weight kg
4PG2PZ	Polymer concrete sump unit with ductile iron edge rail L=500	81,00
4RP2TID	Right-hand end cap for channel closure female side	0,494
4RP2TIS	Left-hand end cap for channel closure male side	0,516
4RP2RI	End cap with outlet for P210 Ø150 mm	0,946
4R02VI	Bucket/filter, AISI 304 stainless steel	1,50

P 210 Series channel with ductile iron edge rail without grating - Length 1000 / 500 mm

Channel L mm	Code	Description	Water passage mm	Run-off section cm ²	Weight kg	Pieces pallet
1000	4PG2S	Additivated polymer concrete P210 channel with ductile iron edge rails, complying with the UNI EN 1433 standard.	153	210	30,42	20
500	4PG2MS	Additivated polymer concrete P210 channel with ductile iron edge rails, complying with the UNI EN 1433 standard.	153	210	15,21	loose

POLYMER CONCRETE CHANNELS P 265 SERIES WITH DUCTILE IRON EDGE RAIL

Grating width 265 mm

Polymer concrete channel with ductile iron edge rails.
The channels are sold exclusively in complete pallets and together with the gratings.



P 265 Series channel with ductile iron edge rail dimensions

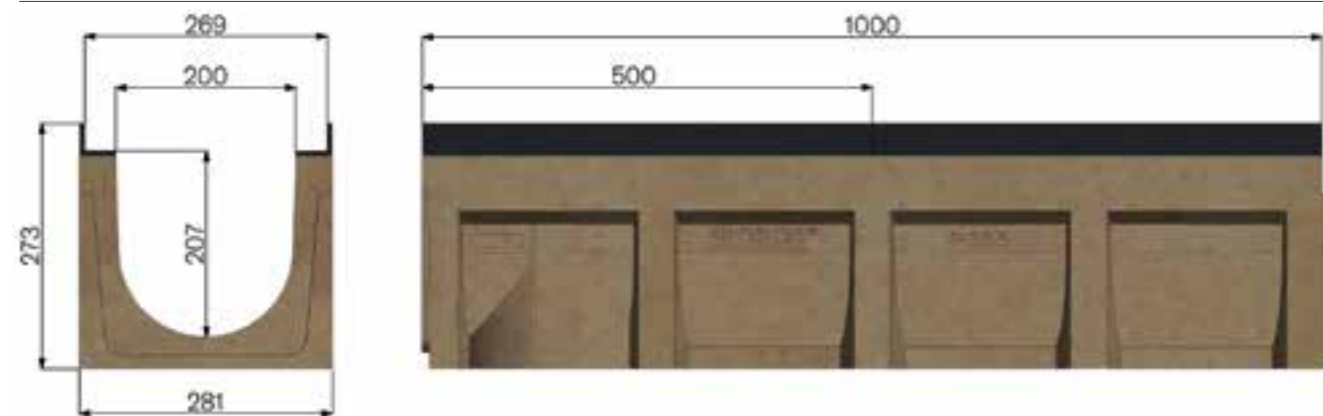

Available gratings



P 265 Series channel with ductile iron edge rail complete with grating - Length 1000 / 500 mm

Channel L mm	Code	Grating	Description of the channel assembled with the grating complete with accessories	Weight kg	Load class
1000	4PG3SGS	①	Channel complete with 2 x GJS500-7 D 400 ductile iron gratings	65,12	D 400
	4PG3SGE	②	Channel complete with 2 x GJS500-7 E 600 ductile iron gratings	71,52	E 600
	4PG3SGF	③	Channel complete with 2 x GJS500-7 F 900 ductile iron gratings	73,32	F 900
500	4PG3MSGS	①	Channel complete with GJS500-7 D 400 ductile iron gratings	32,56	D 400
	4PG3MSGE	②	Channel complete with GJS500-7 E 600 ductile iron gratings	35,76	E 600
	4PG3MSGF	③	Channel complete with GJS500-7 F 900 ductile iron gratings	36,66	F 900

P 265 Series accessories with ductile iron edge rail

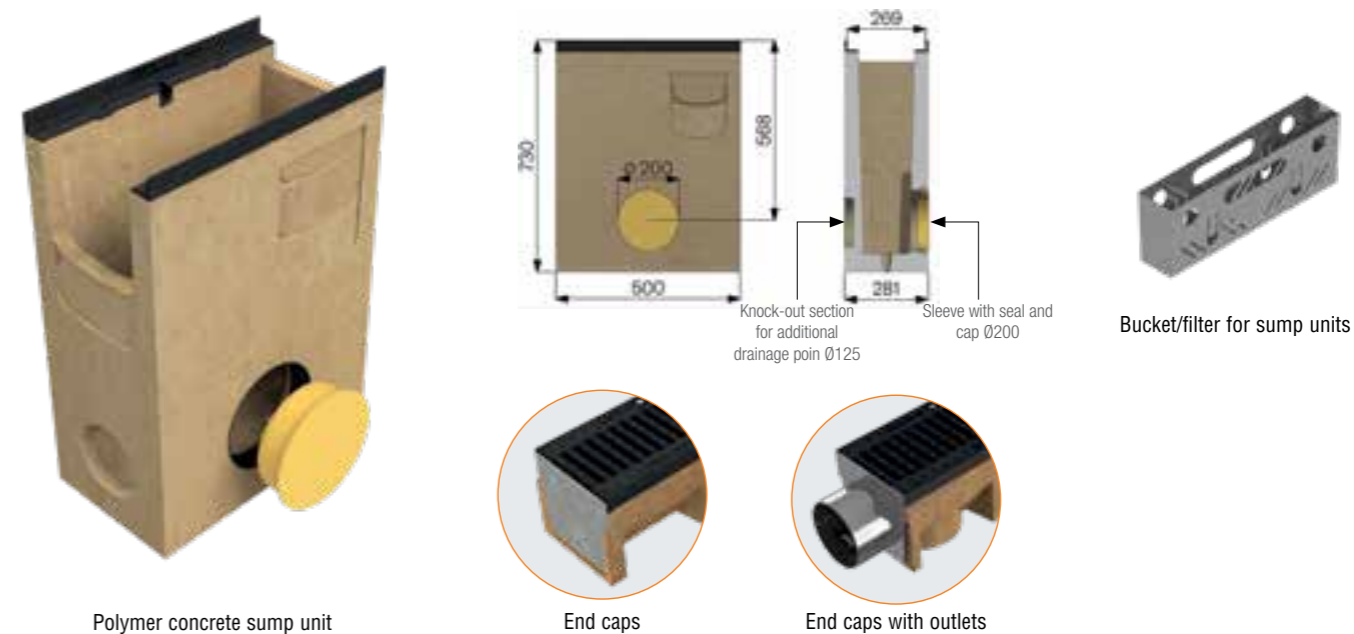

P 265 Series polymer concrete sump unit complete with ductile iron edge rail with grating and accessories - Length 500 mm

Sump unit L mm	Code	Grating	Description of the sump unit assembled with the grating complete with accessories	Weight kg	Load class
500	4PG3PZGS	①	Sump unit complete with GJS500-7 D 400 ductile iron grating	113,45	D 400
	4PG3PZGE	②	Sump unit complete with GJS500-7 E 600 ductile iron grating	119,86	E 600
	4PG3PZGF	③	Sump unit complete with GJS500-7 F 900 ductile iron grating	123,43	F 900

P 265 Series polymer concrete sump unit without ductile iron edge rail with grating and accessories

Code	Description	Weight kg
4PG3PZ	Polymer concrete sump unit with ductile iron edge rail L=500	108,00
4RP3TID	Right-hand end cap for channel closure female side	0,752
4RP3TIS	Left-hand end cap for channel closure male side	0,774
4RP3RI	End cap with outlet for P265 Ø160 mm	1,398
4R03VI	Bucket/filter, AISI 304 stainless steel	1,71

P 265 Series channel with ductile iron edge rail without grating - Length 1000 / 500 mm

Channel L mm	Code	Description	Water passage mm	Run-off section cm ²	Weight kg	Pieces pallet
1000	4PG3S	Additivated polymer concrete P265 channel with ductile iron edge rails, complying with the UNI EN 1433 standard.	200	365	47,30	16
500	4PG3MS	Additivated polymer concrete P265 channel with ductile iron edge rails, complying with the UNI EN 1433 standard.	200	365	23,65	loose

POLYMER CONCRETE CHANNELS P 315 SERIES WITH DUCTILE IRON EDGE RAIL

Grating width 315 mm

Polymer concrete channel with ductile iron edge rails.
The channels are sold exclusively in complete pallets and together with the gratings.



P 315 Series channel with ductile iron edge rail dimensions

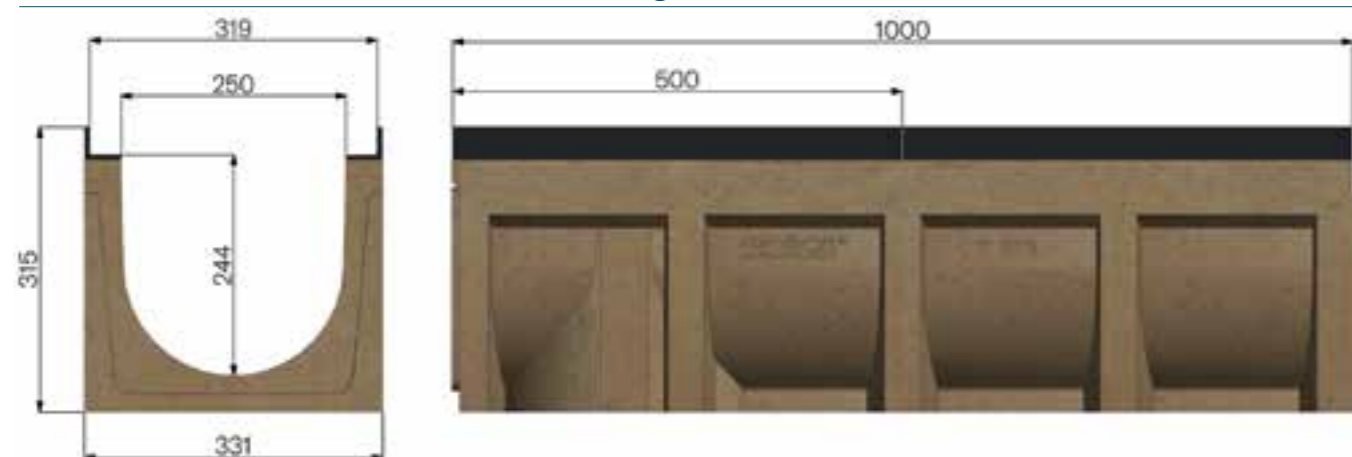

Available gratings



① Ductile iron grating
D 400

② Ductile iron grating
E 600

③ Ductile iron grating
F 900

P 315 Series channel with ductile iron edge rail complete with grating - Length 1000 / 500 mm

Channel L mm	Code	Grating	Description of the channel assembled with the grating complete with accessories	Weight kg	Load class
1000	4PG4SGS	①	Channel complete with 2 x GJS500-7 D 400 ductile iron gratings	86,18	D 400
	4PG4SGE	②	Channel complete with 2 x GJS500-7 E 600 ductile iron gratings	89,86	E 600
	4PG4SGF	③	Channel complete with 2 x GJS500-7 F 900 ductile iron gratings	96,56	F 900
500	4PG4MSGS	①	Channel complete with GJS500-7 D 400 ductile iron gratings	43,09	D 400
	4PG4MSGE	②	Channel complete with GJS500-7 E 600 ductile iron gratings	44,93	E 600
	4PG4MSGF	③	Channel complete with GJS500-7 F 900 ductile iron gratings	48,28	F 900

P 315 Series channel with ductile iron edge rail without grating - Length 1000 / 500 mm

Channel L mm	Code	Description	Water passage mm	Run-off section cm ²	Weight kg	Pieces pallet
1000	4PG4S	Additivated polymer concrete P315 channel with ductile iron edge rails, complying with the UNI EN 1433 standard.	250	536	54,44	9
500	4PG4MS	Additivated polymer concrete P315 channel with ductile iron edge rails, complying with the UNI EN 1433 standard.	250	536	27,22	loose



POLYMER CONCRETE CHANNELS P 365 SERIES WITH DUCTILE IRON EDGE RAIL

Grating width 365 mm

Polymer concrete channel with ductile iron edge rails.
The channels are sold exclusively in complete pallets and together with the gratings.



P 365 Series with ductile iron edge rail channel dimensions

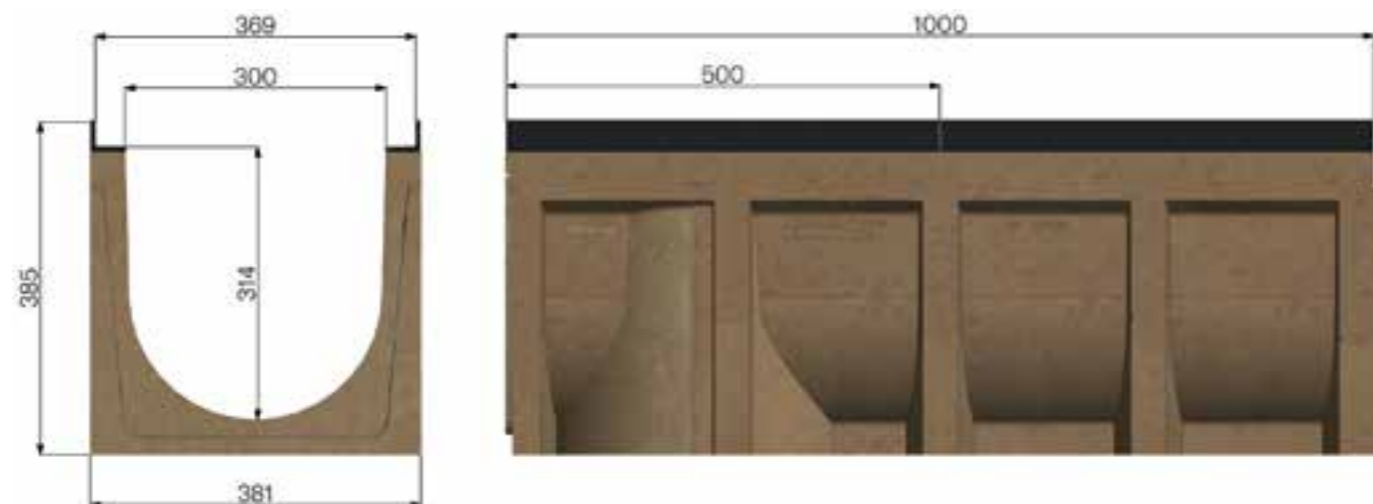

Available gratings



P 365 Series channel with ductile iron edge rail complete with grating - Length 1000 / 500 mm

Channel L mm	Code	Grating	Description of the channel assembled with the grating complete with accessories	Weight kg	Load class
1000	4PG5SGS	①	Channel complete with 2 x GJS500-7 D 400 ductile iron gratings	106,26	D 400
	4PG5SGE	②	Channel complete with 2 x GJS500-7 E 600 ductile iron gratings	113,33	E 600
	4PG5SGF	③	Channel complete with 2 x GJS500-7 F 900 ductile iron gratings	117,25	F 900
500	4PG5MSGS	①	Channel complete with GJS500-7 D 400 ductile iron gratings	53,13	D 400
	4PG5MSGE	②	Channel complete with GJS500-7 E 600 ductile iron gratings	56,66	E 600
	4PG5MSGF	③	Channel complete with GJS500-7 F 900 ductile iron gratings	58,62	F 900

P 365 Series Series accessories with ductile iron edge rail

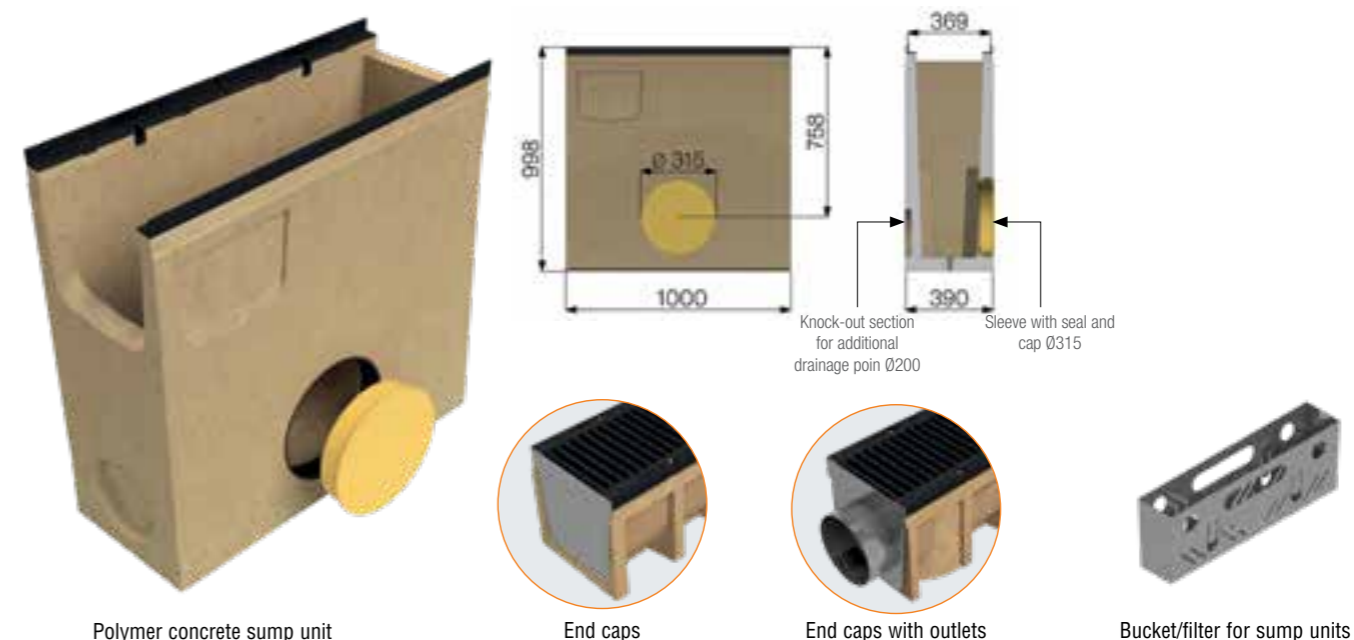

P 365 Series polymer concrete sump unit complete with ductile iron edge rail with grating and accessories - Length 500 mm

Sump unit L mm	Code	Grating	Description of the sump unit assembled with the grating complete with accessories	Weight kg	Load class
500	4PG5PZGS	①	Sump unit complete with GJS500-7 D 400 ductile iron grating	381,90	D 400
	4PG5PZGE	②	Sump unit complete with GJS500-7 E 600 ductile iron grating	384,15	E 600
	4PG5PZGF	③	Sump unit complete with GJS500-7 F 900 ductile iron grating	391,84	F 900

P 365 Series polymer concrete sump unit without ductile iron edge rail with grating and accessories

Code	Description	Weight kg
4PG5PZ	Polymer concrete sump unit with ductile iron edge rail L=1000	338,00
4RP5TID	Right-hand end cap for channel closure female side	2,90
4RP5TIS	Left-hand end cap for channel closure male side	3,10
4RP5RI	End cap with outlet for P365 Ø250 mm	3,10
4R05VI	Bucket/filter, AISI 304 stainless steel	4,14
4R05PR	Galvanised sheet metal raising frame for two-stage channel laying	

P 365 Series channel with ductile iron edge rail without grating - Length 1000 / 500 mm

Channel L mm	Code	Description	Water passage mm	Run-off section cm ²	Weight kg	Pieces pallet
1000	4PG5S	Additivated polymer concrete P365 channel with ductile iron edge rails, complying with the UNI EN 1433 standard.	300	833	64,52	9
500	4PG5MS	Additivated polymer concrete P365 channel with ductile iron edge rails, complying with the UNI EN 1433 standard.	300	833	32,26	loose

POLYMER CONCRETE CHANNELS

POLY FLY SERIES

POLYMER CONCRETE CHANNELS

Thanks to its commitment and on-going research, Gridiron and its staff of chemical industry specialists have expanded the existing range of channels with the new Poly Fly Series polymer concrete range, featuring new-generation, cutting-edge products. Cast polymer concrete is obtained through a mixture of inert quartz materials and polymer resins with the addition of catalysts. Their mechanical resistance and compressive strength hover around 1,000–1,200 kg/cm², while their tensile strength is roughly 200–250 kg/cm². Laboratory tests are carried out on a regular basis to certify compliance of the products with the applicable standards.

ADVANTAGES AND FEATURES

Lightness: particularly light compared to concrete.

Roughness: its smooth and waterproof surface enables water to flow with less friction.

Installation: facilitated handling and installation thanks to its light weight.

Geometrical structure: The product is lightweight, smooth, has precise dimensions and is designed for male-female joining.

Durability: the chemical composition makes it impermeable to water and also to other liquids, including hydrocarbons (petrol and mineral oils).

Certification: complies with the UNI EN 1433 standard.

- POLY FLY 100
- POLY FLY 100 LOW
- POLY FLY 100 WITH SLOPE
- POLY FLY 150
- POLY FLY 150 LOW
- POLY FLY 100 WITH SLOPE
- POLY FLY 200
- POLY FLY 200 LOW
- POLY FLY 300 HIGH
- POLY FLY 300 MEDIUM
- POLY FLY 300 LOW

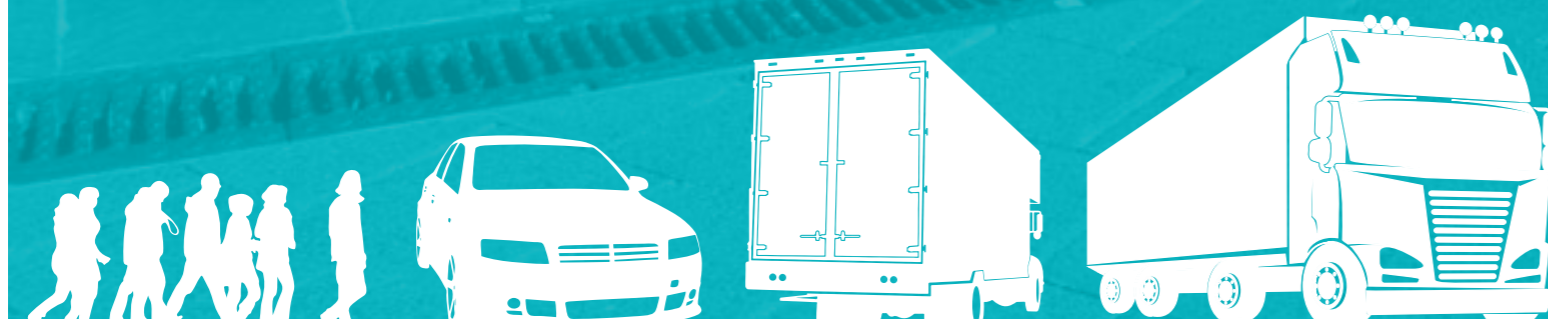

LOAD CLASSES

In accordance with the UNI EN 1433 standard

A 15 • B 125 • C 250 • D 400



POLYMER CONCRETE CHANNELS POLY FLY SERIES

SYSTEM AND TECHNICAL CHARACTERISTICS

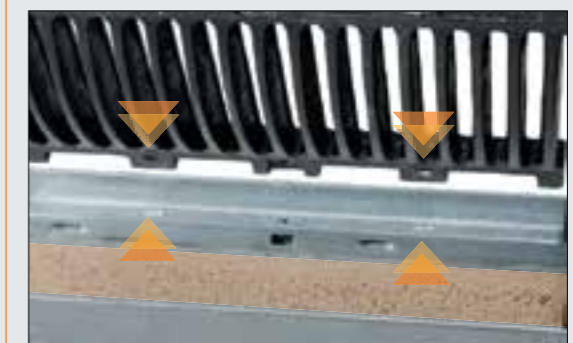
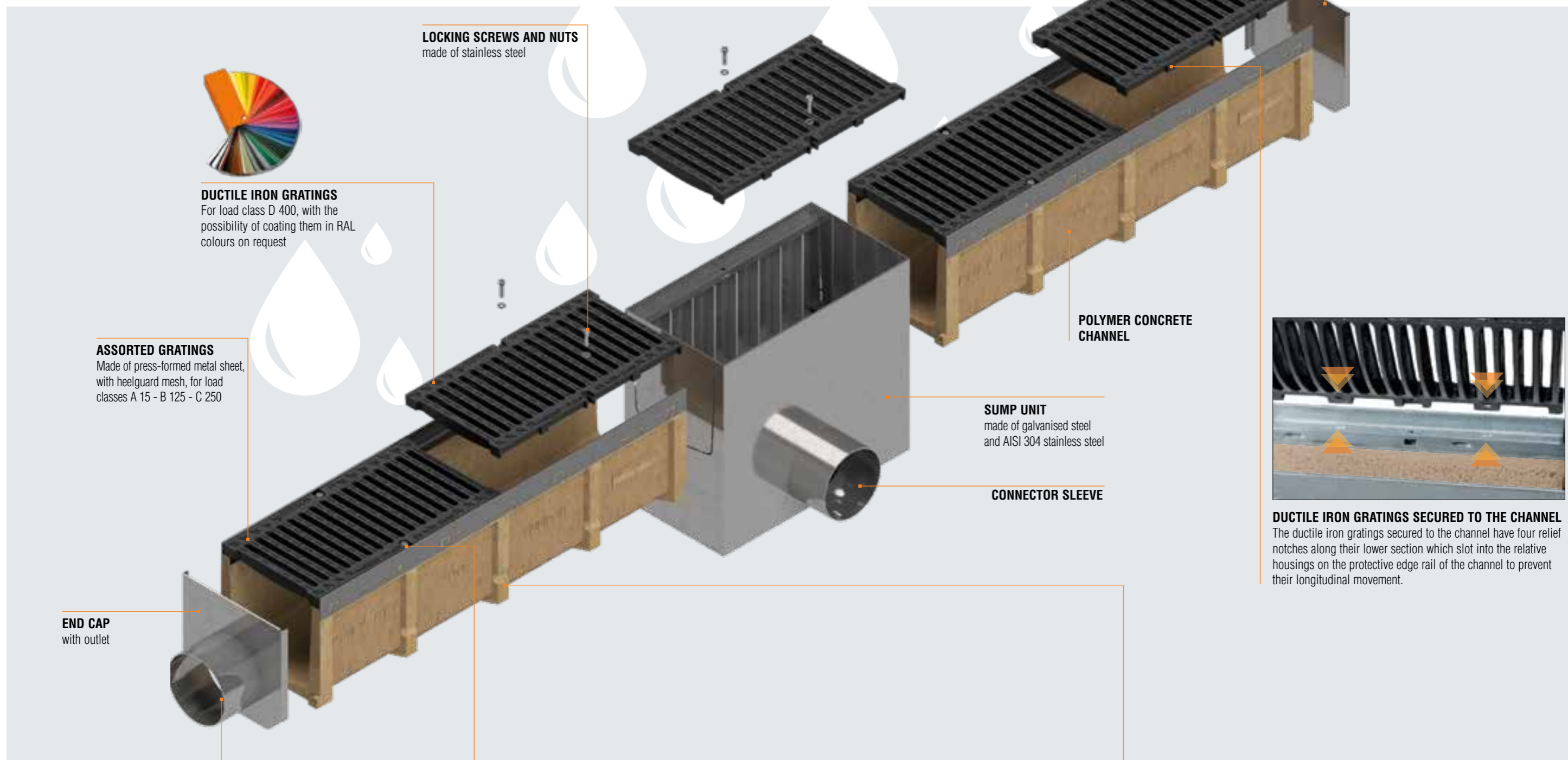

DUCTILE IRON GRATINGS SECURED TO THE CHANNEL
The ductile iron gratings secured to the channel have four relief notches along their lower section which slot into the relative housings on the protective edge rail of the channel to prevent their longitudinal movement.

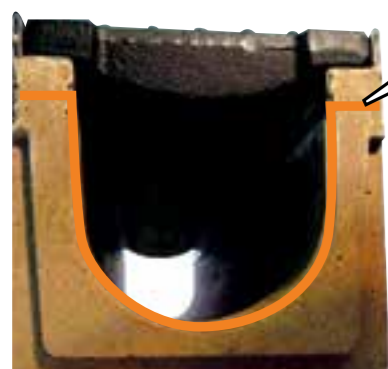

PERFECT AND STABLE JOINING
The channel end caps are made with male-female connections, with an inner slot that allows for sealing them together. We recommend the use of silicone sealant with neutral cross-linkage and low modulus.



SECURE ANCHORING IN THE CONCRETE
Fixing system designed by GRIDIRON: tang embedded into the concrete with a housing for the nut through which the screw is inserted



MAXIMUM SAFETY
To facilitate laying operations, GRIDIRON has created four recesses on each side of the product for improved anchoring to the support and, above all, to facilitate the product's positioning with the aid of specific equipment, thereby reducing the application time and effort.

POLYMER CONCRETE CHANNELS
POLY FLY SERIES
SPECIAL COVERS

Fine design and striking visual appeal: these are the new GRIDIRON "SPECIAL" gratings made of AISI 304 stainless steel and, on request, AISI 316L steel. Combined with POLY FLY polymer concrete channels, they were created to satisfy the most demanding and attentive customers. The Special covers add a touch of elegance and design to the paving in which the channels are laid.

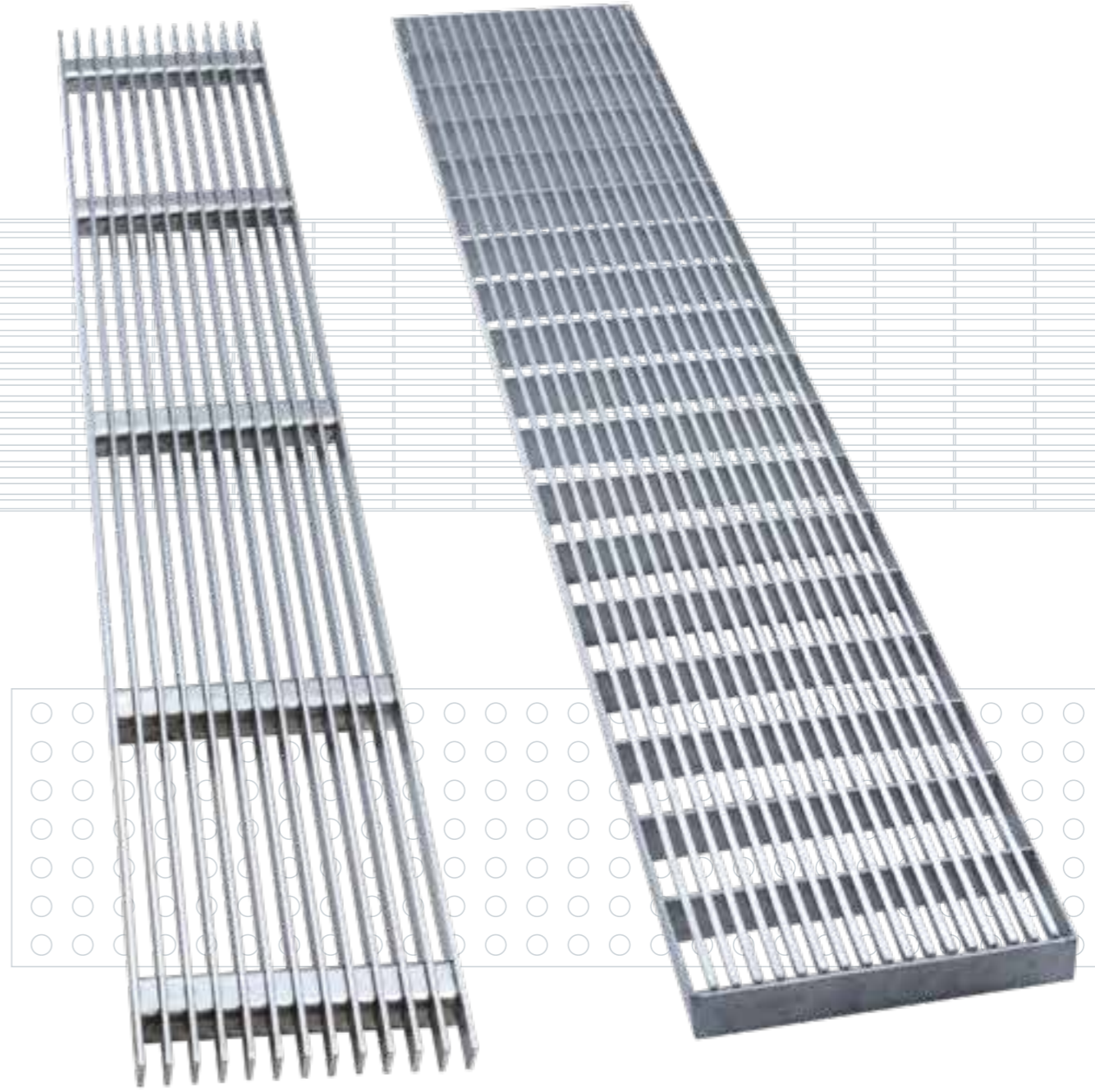

Special grating
HORIZON

Stainless steel grating with U-shaped longitudinal edge rails, heelguard, 6 mm slots, self-locking
B 125

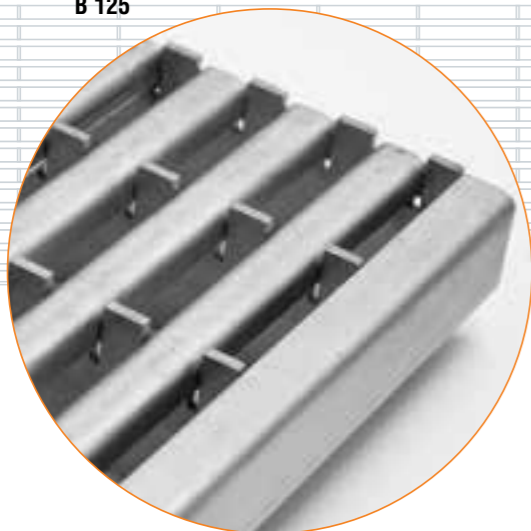

Special grating
MOON

Stainless steel perforated metal sheet grating, Th. 12/10, with Ø10 holes, self-locking
A 15

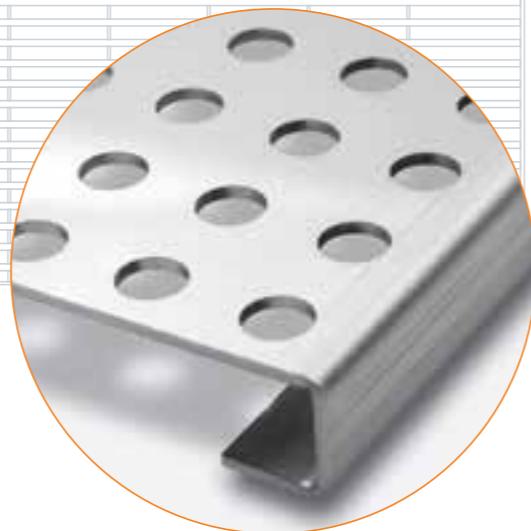

Special grating
METRÒ

Stainless steel grating with 15x3 longitudinal flat bars, self-locking
A 15



Special grating
DOLOMITES

Stainless steel grating with triangular edge rails, self-locking
A 15

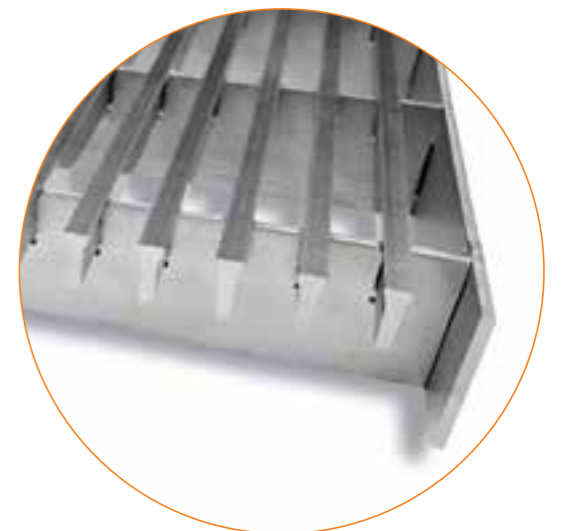

POLYMER CONCRETE CHANNELS

POLY FLY 100 (galvanised edge rail)

Grating width 150 mm

Polymer concrete channel with galvanised edge rails complying with the UNI EN 1433 standard. The channels are sold exclusively in complete pallets and together with the gratings.

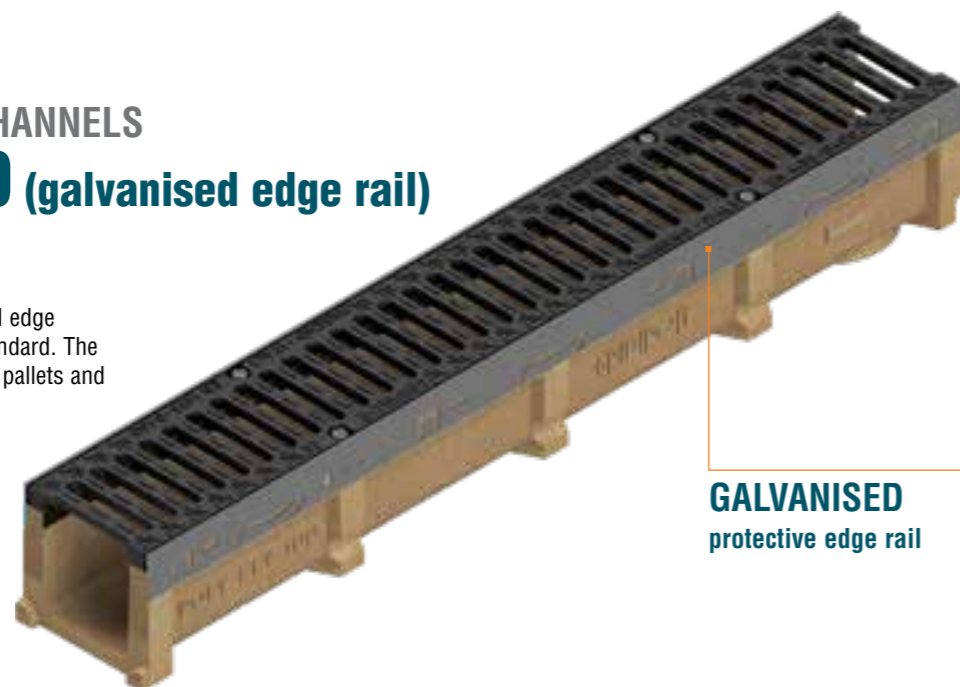

Poly Fly 100 channel dimensions

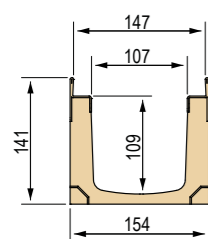

Available gratings



Poly Fly 100 channel (galvanised edge rail) complete with grating - Length 1,000 mm

WITH GALVANISED PROTECTIVE EDGE RAIL

Channel L mm	Code	Grating	Description of the channel assembled with the grating complete with accessories	Weight kg	Load class
1,000	4G02SLC	①	Channel complete with galvanised press-formed metal sheet grating 12/10 with C-shaped edges	15.96	A 15
	4G02SG1	②	Channel complete with pressure-locked grating with C-shaped edges, 20x2-10x2 33x33, hot-dip galvanised	16.68	C 250
	4G02SG2	③	Channel complete with pressure-locked grating with C-shaped edges, 20x2-10x2 55x11 heelguard mesh, hot-dip galvanised	17.38	
	4G02SG3	④	Channel complete with pressure-locked grating with C-shaped edges, 20x2-10x2 33x11 heelguard mesh, hot-dip galvanised	17.95	
	4G02SGS	⑤	Channel complete with 2 x GJS500-7 ductile iron gratings	22.00	D 400
	4G02SGSA	⑥	Channel complete with 2 x GJS500-7 ductile iron heelguard gratings	22.32	
	4G02SP	⑦	Channel complete with embossed metal sheet solid plate Th. 3, reinforced and hot-dip galvanised	24.39	

Poly Fly 100 channel (galvanised edge rail) accessories

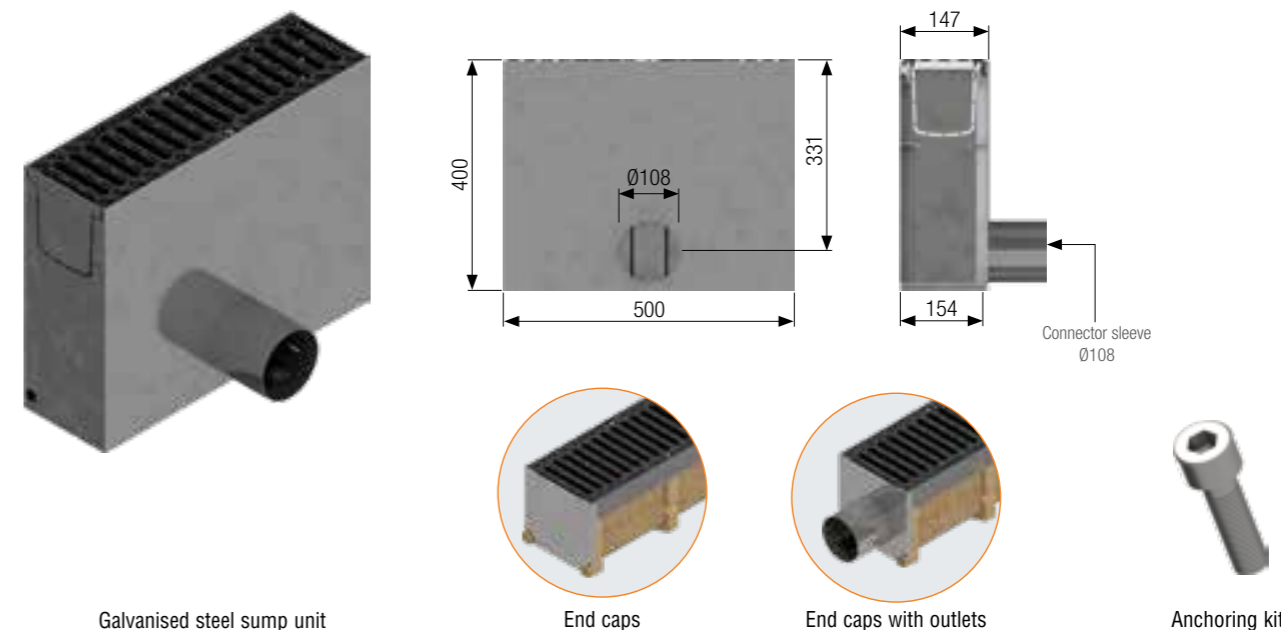

Poly Fly 100 galvanised steel sump unit complete with grating - Length 500 mm

Sump unit L mm	Code	Grating	Description of the sump unit assembled with the grating complete with accessories	Weight kg	Load class
500	4G02PZLC	①	Sump unit complete with galvanised press-formed metal sheet grating 12/10 with C-shaped edges	30.47	A 15
	4G02PZG1	②	Sump unit complete with pressure-locked grating with C-shaped edges, 20x2-10x2 33x33, hot-dip galvanised	31.27	C 250
	4G02PZG2	③	Sump unit complete with pressure-locked grating with C-shaped edges, 20x2-10x2 55x11 heelguard mesh, hot-dip galvanised	31.62	
	4G02PZG3	④	Sump unit complete with pressure-locked grating with C-shaped edges, 20x2-10x2 33x11 heelguard mesh, hot-dip galvanised	31.91	
	4G02PZGS	⑤	Sump unit complete with GJS500-7 ductile iron grating	33.93	D 400
	4G02PZGSA	⑥	Sump unit complete with GJS500-7 ductile iron heelguard grating	34.09	
	4G02PZP	⑦	Sump unit complete with embossed metal sheet solid plate Th. 3, reinforced and hot-dip galvanised	35.13	

Poly Fly 100 galvanised steel sump unit without grating and accessories

Code	Description	Weight kg
4G02PZ	Galvanised steel sump unit L 500 mm	14.23
4G02TI	AISI 304 stainless steel sheet end cap, thickness 15/10	0.30
4G02RI	AISI 304 stainless steel sheet end cap with outlet, thickness 15/10 Ø108 mm	0.52
4D00K	Anchoring kit for galvanised and AISI 304 stainless steel gratings (for gratings 2 - 3 - 4)	0.02
4D00V	Anchoring kit for ductile iron gratings (for gratings 5 - 6)	0.02
4D00P	Anchoring kit for galvanised/AISI 304 stainless steel plates (for plate 7)	0.02

Poly Fly 100 channel (galvanised edge rail) without grating - Length 1,000 mm

Channel L mm	Code	Description	Water passage mm	Run-off section cm²	Weight kg	Pieces pallet
1,000	4G02S	Poly Fly 100 polymer concrete channel with galvanised protective edge rail	107	108	14.14	42

POLYMER CONCRETE CHANNELS

POLY FLY 100

(AISI 304 stainless steel edge rail)

Grating width 150 mm

Polymer concrete channel with stainless steel edge rails complying with the UNI EN 1433 standard. The channels are sold exclusively in complete pallets and together with the gratings.

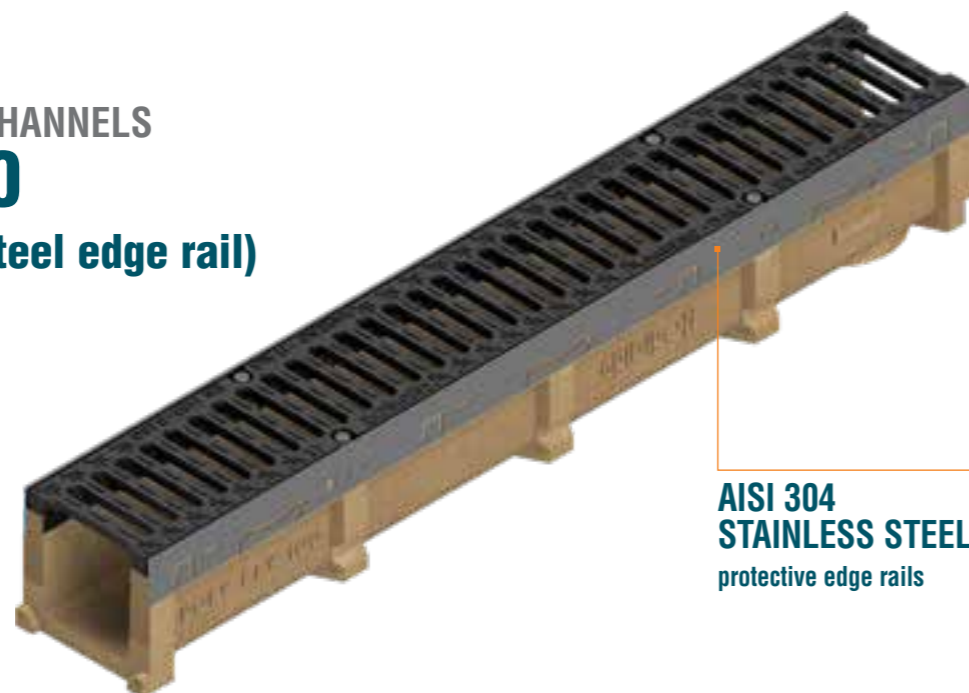

AISI 304 STAINLESS STEEL
protective edge rails

Poly Fly 100 channel dimensions

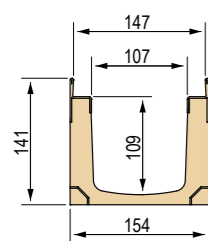

Available gratings



Poly Fly 100 channel (AISI 304 stainless steel edge rail) complete with grating - Length 1,000 mm

WITH AISI 304 STAINLESS STEEL PROTECTIVE EDGE RAIL

Channel L mm	Code	Grating	Description of the channel assembled with the grating complete with accessories	Weight kg	Load class
1,000	4G03SLC1	①	Channel complete with AISI 304 stainless steel press-formed metal sheet grating 12/10 with C-shaped edges	15.96	A 15
	4G03SX1	②	Channel complete with pressure-locked grating with edging, 20x2-10x2 33x33, AISI 304 stainless steel	17.69	
	4G03SX2	③	Channel complete with pressure-locked grating with edging, 20x2-10x2 55x11 heelguard mesh, AISI 304 stainless steel	17.94	C 250
	4G03SX3	④	Channel complete with pressure-locked grating with edging, 20x2-10x2 33x11 heelguard mesh, AISI 304 stainless steel	18.74	
	4G03SX4	⑤	Channel complete with pressure-locked grating with edging, 20x3-10x2 25x25, AISI 304 stainless steel	18.50	D 400
	4G03SPI	⑥	Channel complete with embossed metal sheet solid plate Th. 3, AISI 304 stainless steel, reinforced	24.39	

Poly Fly 100 channel (AISI 304 stainless steel edge rail) accessories

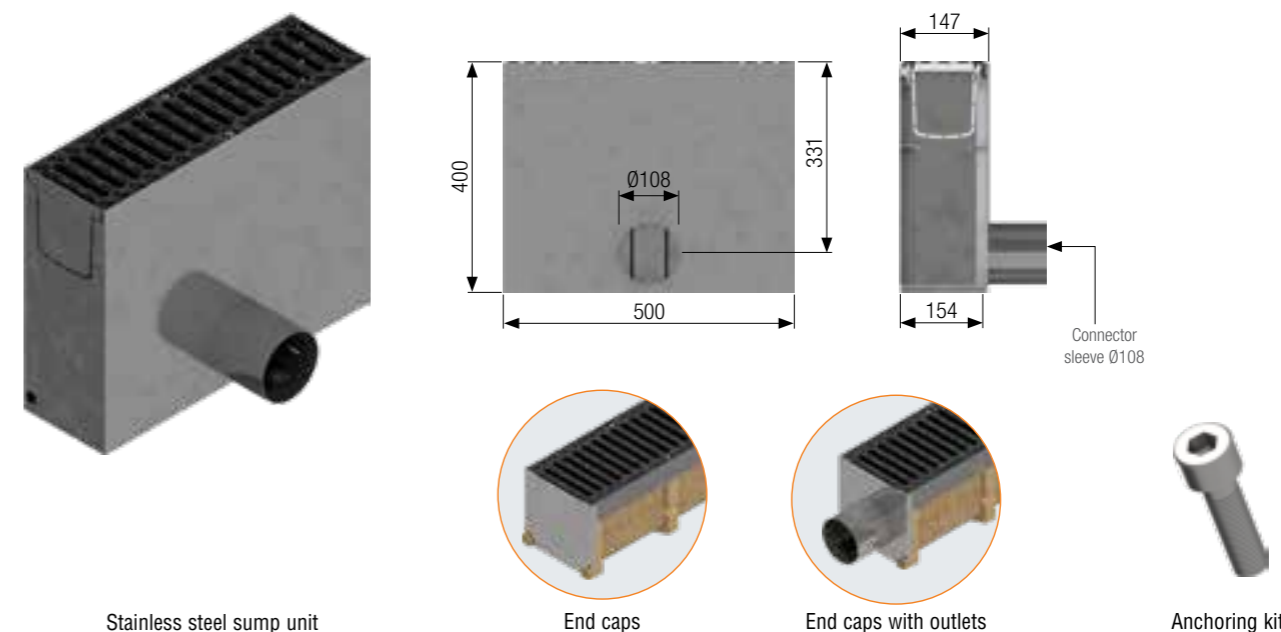

Stainless steel sump unit

End caps

End caps with outlets

Anchoring kit

Poly Fly 100 AISI 304 stainless steel sump unit complete with grating - Length 500 mm

Sump unit L mm	Code	Grating	Description of the sump unit assembled with the grating complete with accessories	Weight kg	Load class
500	4G03PILC1	①	Sump unit complete with AISI 304 stainless steel press-formed metal sheet grating 12/10 with C-shaped edges	30.91	A 15
	4G03PIX1	②	Sump unit complete with pressure-locked grating with edging, 20x2-10x2 33x33, AISI 304 stainless steel	31.78	
	4G03PIX2	③	Sump unit complete with pressure-locked grating with edging, 20x2-10x2 55x11, heelguard mesh, AISI 304 stainless steel	31.90	C 250
	4G03PIX3	④	Sump unit complete with pressure-locked grating with edging, 20x2-10x2 33x11, heelguard mesh, AISI 304 stainless steel	32.30	
	4G03PIX4	⑤	Sump unit complete with pressure-locked grating with edging, 20x3-10x2 25x25, AISI 304 stainless steel	32.18	D 400
	4G03PIPI	⑥	Sump unit complete with embossed metal sheet solid plate Th. 3, AISI 304 stainless steel, reinforced	35.13	

Poly Fly 100 AISI 304 stainless steel sump unit without grating and accessories

Code	Description	Weight kg
4G03PI	AISI 304 stainless steel sump unit L 500 mm	14.23
4G02TI	AISI 304 stainless steel sheet end cap, thickness 15/10	0.30
4G02RI	AISI 304 stainless steel sheet end cap with outlet, thickness 15/10 Ø108 mm	0.52
4D00K	Anchoring kit for galvanised and AISI 304 stainless steel gratings (for gratings 2 - 5)	0.02
4D00A	Anchoring kit for AISI 304 stainless steel heelguard gratings (for gratings 3 - 4)	0.02
4D00P	Anchoring kit for AISI 304 stainless steel plates (for plate 6)	0.02

Poly Fly 100 channel (AISI 304 stainless steel edge rail) without grating - Length 1,000 mm

Channel L mm	Code	Description	Water passage mm	Run-off section cm ²	Weight kg	Pieces pallet
1,000	4G03S	Poly Fly 100 polymer concrete channel with AISI 304 stainless steel protective edge rail	107	108	14.52	42

POLYMER CONCRETE CHANNELS POLY FLY 100 WITH SPECIAL COVER

Grating width 150 mm

Polymer concrete channel with stainless steel edge rails complying with the UNI EN 1433 standard. The channels are sold exclusively in complete pallets and together with the gratings.

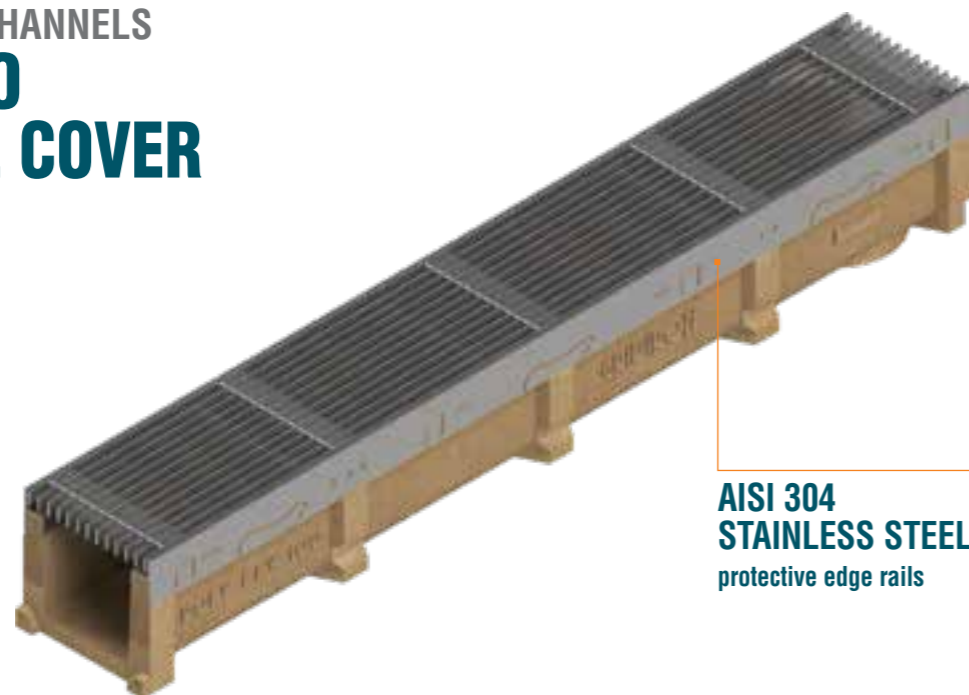

Poly Fly 100 channel dimensions

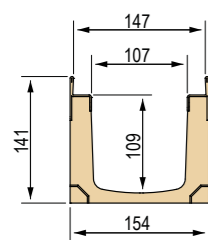

Available gratings N.B.: AISI 316 stainless steel version available on request.

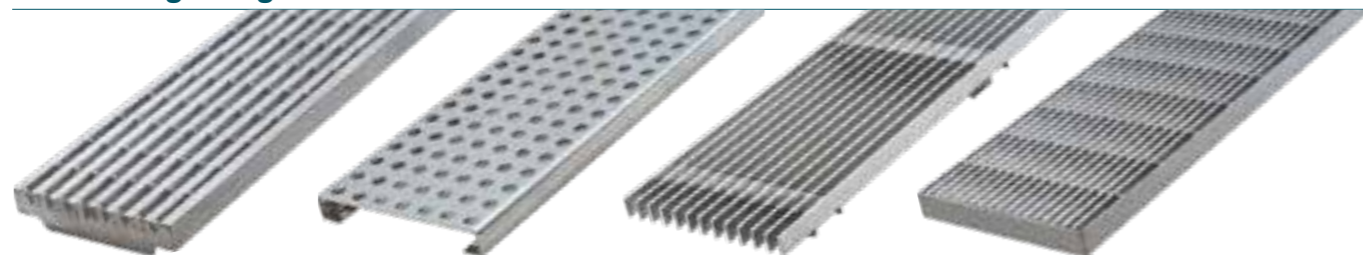

- ① "HORIZON" grating **B 125**
- ② "MOON" grating **A 15**
- ③ "METRÒ" grating **A 15**
- ④ "DOLOMITES" grating **A 15**

Poly Fly 100 channel complete with grating - Length 1,000 mm

WITH AISI 304 STAINLESS STEEL PROTECTIVE EDGE RAILS

Channel L mm	Code	Grating	Description of the channel assembled with the grating complete with accessories	Weight kg	Load class
1,000	4G03SD1	①	Channel complete with "HORIZON" model AISI 304 stainless steel grating with U-shaped longitudinal edge rails, heelguard 6 mm slots, self-locking	18.34	B 125
	4G03SD2	②	Channel complete with "MOON" model AISI 304 stainless steel grating, Th. 12/10 metal sheet, Ø10 holes, self-locking	16.34	A 15
	4G03SD3	③	Channel complete with "METRÒ" model AISI 304 stainless steel grating, with longitudinal 15x3 plates, self-locking	17.84	
	4G03SD4	④	Channel complete with "DOLOMITES" model AISI 304 stainless steel grating, with triangular edge rails, self-locking	18.83	

Accessories for Poly Fly 100 channel with Special cover

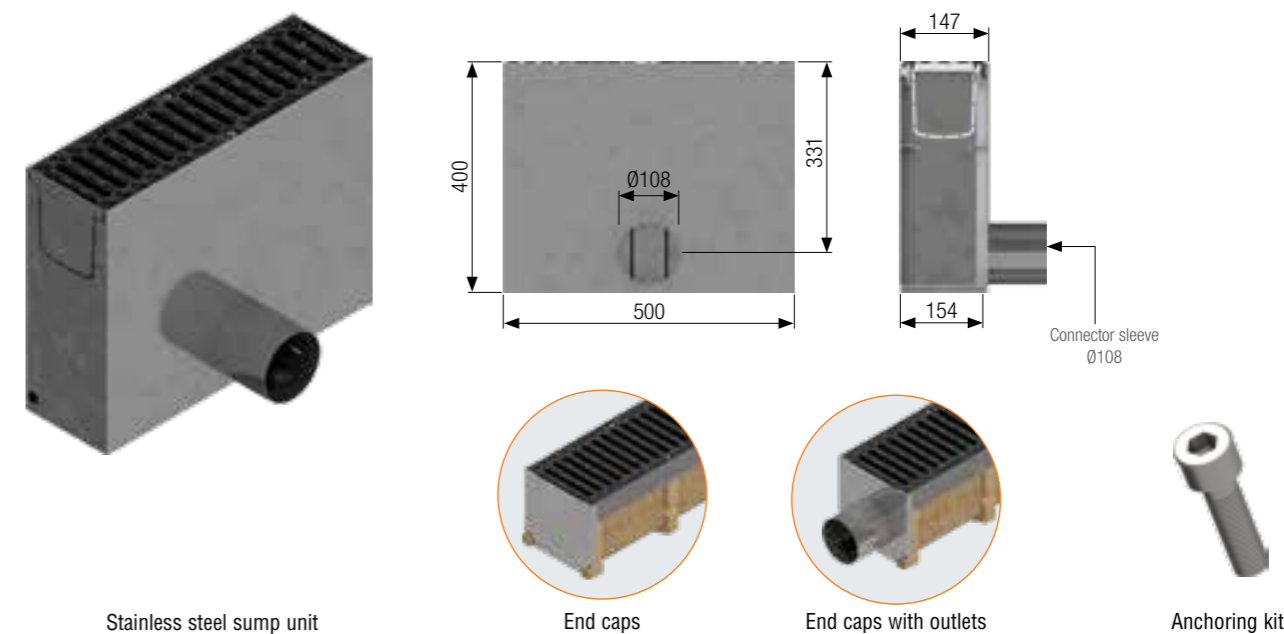

Poly Fly 100 AISI 304 stainless steel sump unit complete with grating - Length 500 mm

Sump unit L mm	Code	Grating	Description of the sump unit assembled with the grating complete with accessories	Weight kg	Load class
500	4G03PID1	①	Sump unit complete with "HORIZON" model AISI 304 stainless steel grating with U-shaped longitudinal edge rails, heelguard 6 mm slots, self-locking	32.10	B 125
	4G03PID2	②	Sump unit complete with "MOON" model AISI 304 stainless steel grating, Th. 12/10 metal sheet, Ø10 holes, self-locking	31.10	A 15
	4G03PID3	③	Sump unit complete with "METRÒ" model AISI 304 stainless steel grating, with longitudinal 15x3 plates, self-locking	31.85	
	4G03PID4	④	Sump unit complete with "DOLOMITES" model AISI 304 stainless steel grating, with triangular edge rails, self-locking	31.63	

Poly Fly 100 AISI 304 stainless steel sump unit without grating and accessories

Code	Description	Weight kg
4G03PI	AISI 304 stainless steel sump unit L 500 mm	14.23
4G02TI	AISI 304 stainless steel sheet end cap, thickness 15/10	0.30
4G02RI	AISI 304 stainless steel sheet end cap with outlet, thickness 15/10, Ø108 mm	0.52

Poly Fly 100 channel without grating - Length 1,000 mm

Channel L mm	Code	Description	Water passage mm	Run-off section cm ²	Weight kg	Pieces pallet
1,000	4G03S	Poly Fly 100 polymer concrete channel with AISI 304 stainless steel protective edge rail	107	108	14.52	42

POLYMER CONCRETE CHANNELS

POLY FLY 100 WITH THIN COVER

CENTRAL SLOT

Polymer concrete channel with galvanised or stainless steel edge rails complying with the UNI EN 1433 standard. The channels are sold exclusively in complete pallets and together with the gratings.

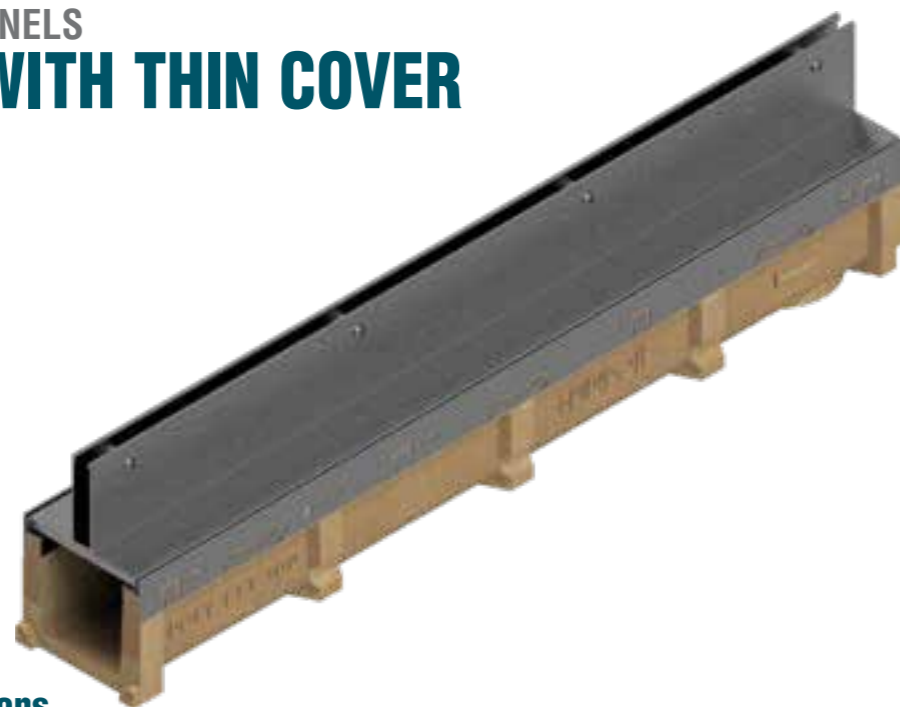

Poly Fly 100 channel dimensions

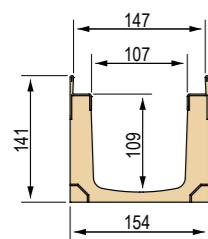

Available Thin covers

N.B.: available on request with 10 mm heelguard slot and in AISI 316 stainless steel

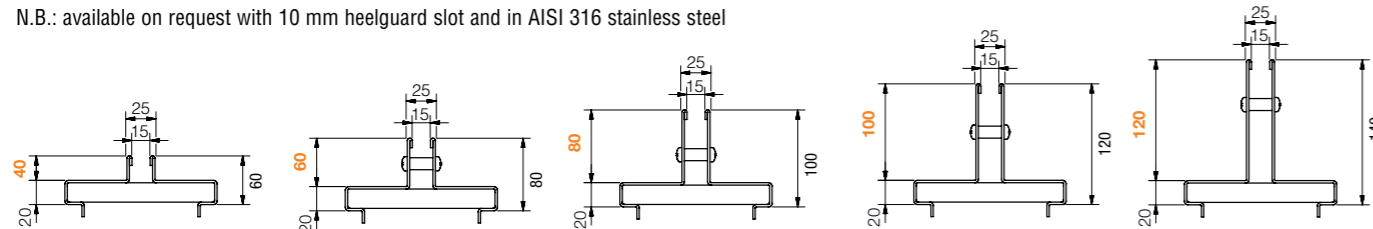

Poly Fly 100 channel without grating - Length 1,000 mm

Channel L mm	Code	Description	Water passage mm	Run-off section cm ²	Weight kg	Pieces pallet
1,000	4G02S	Poly Fly 100 polymer concrete channel with galvanised protective edge rail	107	108	14.14	loose
	4G03S	Poly Fly 100 polymer concrete channel with AISI 304 stainless steel protective edge rail	107	108	14.52	loose

Galvanised steel or AISI 304 stainless steel Poly Fly 100 sump unit without grating

Sump unit L mm	Code	Description	Weight kg
500	4G02PZ	Galvanised steel sump unit L 500 mm	14.23
	4G03PI	AISI 304 stainless steel sump unit L 500 mm	14.23



Thin covers with central slot - Slot width 15 mm

GALVANISED

Cover L mm	Code	Description	Slot height mm	Weight kg	Load class
1,000	4G02T0	Thin central cover, hot-dip galvanised, Th. 20/10	40	5.28	C 250
	4G02T	Thin central cover, hot-dip galvanised, Th. 20/10	60	5.91	
	4G02T1	Thin central cover, hot-dip galvanised, Th. 20/10	80	6.54	D 400
	4G02T2	Thin central cover, hot-dip galvanised, Th. 20/10	100	7.17	
	4G02T3	Thin central cover, hot-dip galvanised, Th. 20/10	120	7.29	
500	4G05T0	Thin central cover, hot-dip galvanised, Th. 20/10	40	2.63	C 250
	4G05T	Thin central cover, hot-dip galvanised, Th. 20/10	60	2.95	
	4G05T1	Thin central cover, hot-dip galvanised, Th. 20/10	80	3.27	D 400
	4G05T2	Thin central cover, hot-dip galvanised, Th. 20/10	100	3.58	
	4G05T3	Thin central cover, hot-dip galvanised, Th. 20/10	120	3.90	

N.B.: the Thin cover is supplied loose

AISI 304 STAINLESS STEEL

Cover L mm	Code	Description	Slot height mm	Weight kg	Load class
1,000	4G03I0	Thin central cover made of AISI 304 stainless steel, Th. 20/10	40	5.28	C 250
	4G03I	Thin central cover made of AISI 304 stainless steel Th. 20/10	60	5.91	
	4G03I1	Thin central cover made of AISI 304 stainless steel Th. 20/10	80	6.54	D 400
	4G03I2	Thin central cover made of AISI 304 stainless steel Th. 20/10	100	7.17	
	4G03I3	Thin central cover made of AISI 304 stainless steel Th. 20/10	120	7.29	
500	4G05I0	Thin central cover made of AISI 304 stainless steel, Th. 20/10	40	2.63	C 250
	4G05I	Thin central cover made of AISI 304 stainless steel Th. 20/10	60	2.95	
	4G05I1	Thin central cover made of AISI 304 stainless steel Th. 20/10	80	3.27	D 400
	4G05I2	Thin central cover made of AISI 304 stainless steel Th. 20/10	100	3.58	
	4G05I3	Thin central cover made of AISI 304 stainless steel Th. 20/10	120	3.90	

N.B.: the Thin cover is supplied loose



Inspection buckets for Thin covers with central slot - Slot width 15 mm

GALVANISED

Bucket L mm	Code	Description	Slot height mm	Weight kg	Load class
500	4G02V0	Inspection bucket for galvanised Thin central cover	40	3.97	C 250
	4G02V	Inspection bucket for galvanised Thin central cover	60	4.72	
	4G02V1	Inspection bucket for galvanised Thin central cover	80	5.46	D 400
	4G02V2	Inspection bucket for galvanised Thin central cover	100	6.20	
	4G02V3	Inspection bucket for galvanised Thin central cover	120	6.94	

N.B.: the Thin bucket is supplied loose

AISI 304 STAINLESS STEEL

Bucket L mm	Code	Description	Slot height mm	Weight kg	Load class
500	4G03V0	Inspection bucket for Thin central cover made of AISI 304 stainless steel	40	3.97	C 250
	4G03V	Inspection bucket for Thin central cover made of AISI 304 stainless steel	60	4.72	
	4G03V1	Inspection bucket for Thin central cover made of AISI 304 stainless steel	80	5.46	D 400
	4G03V2	Inspection bucket for Thin central cover made of AISI 304 stainless steel	100	6.20	
	4G03V3	Inspection bucket for Thin central cover made of AISI 304 stainless steel	120	6.94	

N.B.: the Thin bucket is supplied loose

POLYMER CONCRETE CHANNELS

POLY FLY 100 WITH THIN COVER

SIDE SLOT

Polymer concrete channel with galvanised or stainless steel edge rails complying with the UNI EN 1433 standard. The channels are sold exclusively in complete pallets and together with the gratings.



Poly Fly 100 channel dimensions

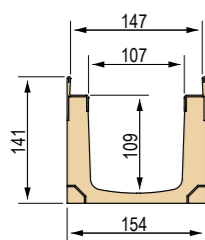

Available Thin covers

N.B.: available on request with 10 mm heelguard slot and in AISI 316 stainless steel

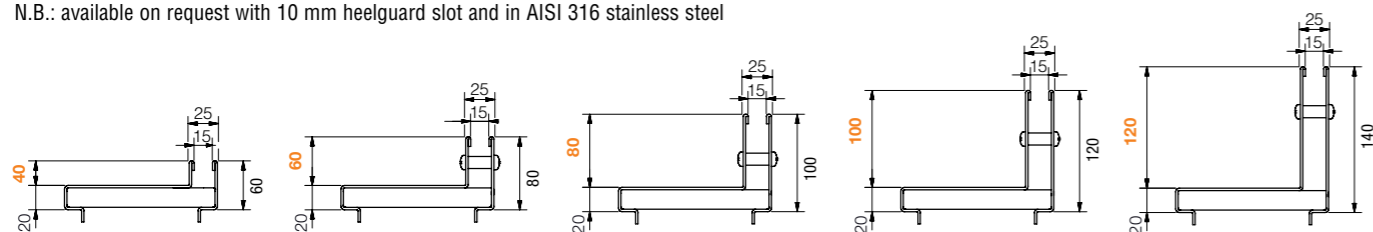

Poly Fly 100 channel without grating - Length 1,000 mm

Channel L mm	Code	Description	Water passage mm	Run-off section cm ²	Weight kg	Pieces pallet
1,000	4G02S	Poly Fly 100 polymer concrete channel with galvanised protective edge rail	107	108	14.14	loose
	4G03S	Poly Fly 100 polymer concrete channel with AISI 304 stainless steel protective edge rail	107	108	14.52	loose

Galvanised steel or AISI 304 stainless steel Poly Fly 100 sump unit without grating

Sump unit L mm	Code	Description	Weight kg
500	4G02PZ	Galvanised steel sump unit L 500 mm	14.23
	4G03PI	AISI 304 stainless steel sump unit L 500 mm	14.23



Thin covers with side slot - Slot width 15 mm

GALVANISED

Cover L mm	Code	Description	Slot height mm	Weight kg	Load class
1,000	4G02L0	Thin side cover, hot-dip galvanised, Th. 20/10	40	5.28	C 250
	4G02L	Thin side cover, hot-dip galvanised, Th. 20/10	60	5.91	
	4G02L1	Thin side cover, hot-dip galvanised, Th. 20/10	80	6.54	D 400
	4G02L2	Thin side cover, hot-dip galvanised, Th. 20/10	100	7.17	
	4G02L3	Thin side cover, hot-dip galvanised, Th. 20/10	120	7.29	
500	4G05L0	Thin side cover, hot-dip galvanised, Th. 20/10	40	2.63	C 250
	4G05L	Thin side cover, hot-dip galvanised, Th. 20/10	60	2.95	
	4G05L1	Thin side cover, hot-dip galvanised, Th. 20/10	80	3.27	D 400
	4G05L2	Thin side cover, hot-dip galvanised, Th. 20/10	100	3.58	
	4G05L3	Thin side cover, hot-dip galvanised, Th. 20/10	120	3.90	

N.B.: the Thin cover is supplied loose

AISI 304 STAINLESS STEEL

Cover L mm	Code	Description	Slot height mm	Weight kg	Load class
1,000	4G03IL0	Thin side cover made of AISI 304 stainless steel Th. 20/10	40	5.28	C 250
	4G03IL	Thin side cover made of AISI 304 stainless steel Th. 20/10	60	5.91	
	4G03IL1	Thin side cover made of AISI 304 stainless steel Th. 20/10	80	6.54	D 400
	4G03IL2	Thin side cover made of AISI 304 stainless steel Th. 20/10	100	7.17	
	4G03IL3	Thin side cover made of AISI 304 stainless steel Th. 20/10	120	7.29	
500	4G05IL0	Thin side cover made of AISI 304 stainless steel, Th. 20/10	40	2.63	C 250
	4G05IL	Thin side cover made of AISI 304 stainless steel Th. 20/10	60	2.95	
	4G05IL1	Thin side cover made of AISI 304 stainless steel Th. 20/10	80	3.27	D 400
	4G05IL2	Thin side cover made of AISI 304 stainless steel Th. 20/10	100	3.58	
	4G05IL3	Thin side cover made of AISI 304 stainless steel Th. 20/10	120	3.90	

N.B.: the Thin cover is supplied loose



Inspection buckets for Thin covers with side slot - Slot width 15 mm

GALVANISED

Bucket L mm	Code	Description	Slot height mm	Weight kg	Load class
500	4G02VL0	Inspection bucket for galvanised Thin side cover	40	3.97	C 250
	4G02VL	Inspection bucket for galvanised Thin side cover	60	4.72	
	4G02VL1	Inspection bucket for galvanised Thin side cover	80	5.46	D 400
	4G02VL2	Inspection bucket for galvanised Thin side cover	100	6.20	
	4G02VL3	Inspection bucket for galvanised Thin side cover	120	6.94	

N.B.: the Thin bucket is supplied loose

AISI 304 STAINLESS STEEL

Bucket L mm	Code	Description	Slot height mm	Weight kg	Load class
500	4G05VL10	Inspection bucket for Thin side cover made of AISI 304 stainless steel	40	3.97	C 250
	4G05VLI	Inspection bucket for Thin side cover made of AISI 304 stainless steel	60	4.72	
	4G05VL11	Inspection bucket for Thin side cover made of AISI 304 stainless steel	80	5.46	D 400
	4G05VL12	Inspection bucket for Thin side cover made of AISI 304 stainless steel	100	6.20	
	4G05VL13	Inspection bucket for Thin side cover made of AISI 304 stainless steel	120	6.94	

N.B.: the Thin bucket is supplied loose

POLYMER CONCRETE CHANNELS **POLY FLY 100 Low** (galvanised edge rail)

Grating width 150 mm

Polymer concrete channel with galvanised edge rails complying with the UNI EN 1433 standard. The channels are sold exclusively in complete pallets and together with the gratings.

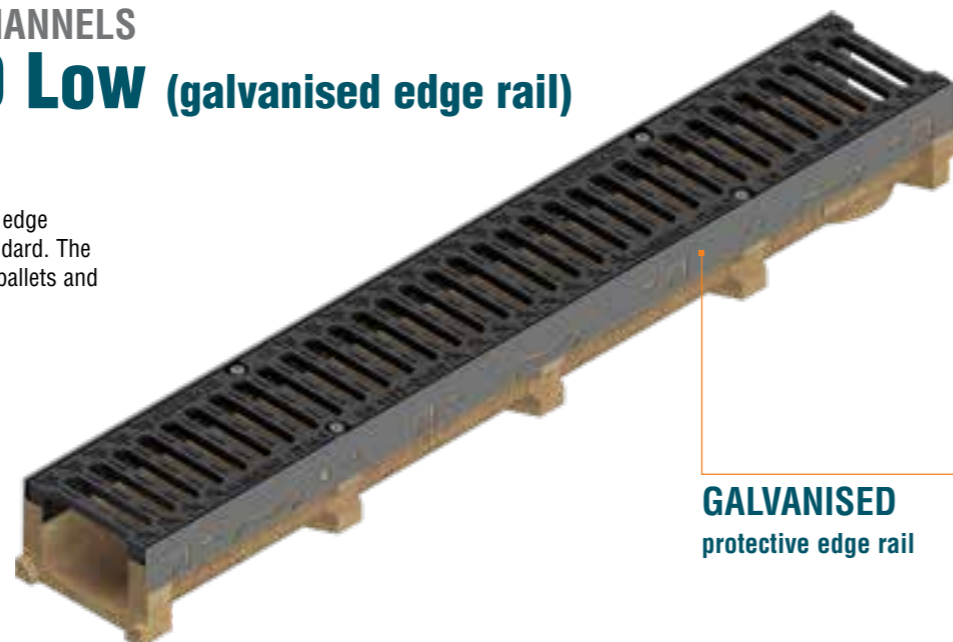

GALVANISED
protective edge rail

Poly Fly 100 Low channel dimensions

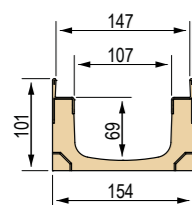

Available gratings



Poly Fly 100 Low channel (galvanised edge rail) complete with grating - Length 1,000 mm

WITH GALVANISED PROTECTIVE EDGE RAIL

Channel L mm	Code	Grating	Description of the channel assembled with the grating complete with accessories	Weight kg	Load class
1,000	4G0CSLC	①	Channel complete with galvanised press-formed metal sheet grating 12/10 with C-shaped edges	13.04	A 15
	4G0CSG1	②	Channel complete with pressure-locked grating with C-shaped edges, 20x2-10x2 33x33, hot-dip galvanised	13.76	C 250
	4G0CSG2	③	Channel complete with pressure-locked grating with C-shaped edges, 20x2-10x2 55x11 heelguard mesh, hot-dip galvanised	14.46	
	4G0CSG3	④	Channel complete with pressure-locked grating with C-shaped edges, 20x2-10x2 33x11 heelguard mesh, hot-dip galvanised	15.03	
	4G0CSGS	⑤	Channel complete with 2 x GJS500-7 ductile iron gratings	19.08	D 400
	4G0CSGSA	⑥	Channel complete with 2 x GJS500-7 ductile iron heelguard gratings	19.40	
	4G0CSP	⑦	Channel complete with embossed metal sheet solid plate Th. 3, reinforced and hot-dip galvanised	21.47	

Poly Fly 100 Low channel (galvanised edge rail) accessories

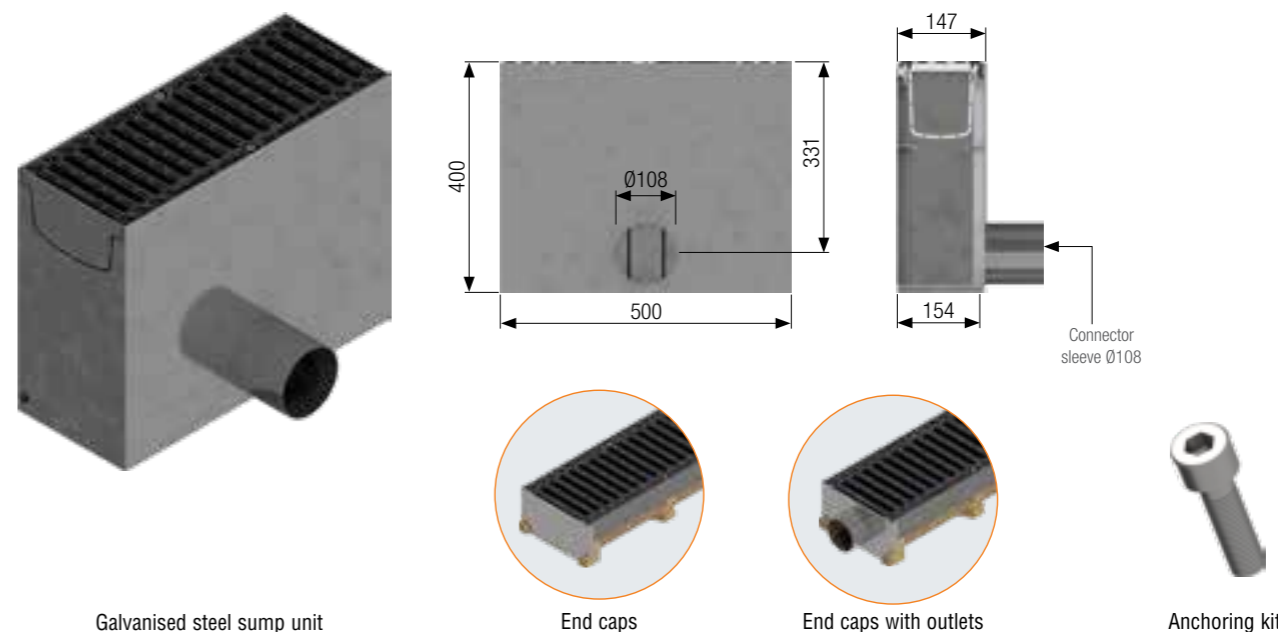

Galvanised steel sump unit

End caps

End caps with outlets

Anchoring kit

Poly Fly 100 Low galvanised steel sump unit complete with grating - Length 500 mm

Sump unit L mm	Code	Grating	Description of the sump unit assembled with the grating complete with accessories	Weight kg	Load class
500	4G02PZLC	①	Sump unit complete with galvanised press-formed metal sheet grating 12/10 with C-shaped edges	30.47	A 15
	4G02PZG1	②	Sump unit complete with pressure-locked grating with C-shaped edges, 20x2-10x2 33x33, hot-dip galvanised	31.27	C 250
	4G02PZG2	③	Sump unit complete with pressure-locked grating with C-shaped edges, 20x2-10x2 55x11 heelguard mesh, hot-dip galvanised	31.62	
	4G02PZG3	④	Sump unit complete with pressure-locked grating with C-shaped edges, 20x2-10x2 33x11 heelguard mesh, hot-dip galvanised	31.91	
	4G02PZGS	⑤	Sump unit complete with GJS500-7 ductile iron grating	33.93	D 400
	4G02PZGSA	⑥	Sump unit complete with GJS500-7 ductile iron heelguard grating	34.09	
	4G02PZP	⑦	Sump unit complete with embossed metal sheet solid plate Th. 3, reinforced and hot-dip galvanised	35.13	

Poly Fly 100 Low galvanised steel sump unit without grating and accessories

Code	Description	Weight kg
4G02PZ	Galvanised steel sump unit L 500 mm	14.23
4G0DTI	AISI 304 stainless steel sheet end cap, thickness 15/10	0.20
4G0DRI	AISI 304 stainless steel sheet end cap with outlet, thickness 15/10 Ø60 mm	0.48
4D00K	Anchoring kit for galvanised and AISI 304 stainless steel gratings (for gratings 2 - 3 - 4)	0.02
4D00V	Anchoring kit for ductile iron gratings (for gratings 5 - 6)	0.02
4D00P	Anchoring kit for galvanised/AISI 304 stainless steel plates (for plate 7)	0.02

Poly Fly 100 Low channel (galvanised edge rail) without grating - Length 1,000 mm

Channel L mm	Code	Description	Water passage mm	Run-off section cm ²	Weight kg	Pieces pallet
1,000	4G0CS	Poly Fly 100 Low polymer concrete channel with galvanised protective edge rail	107	70	11.22	78

POLYMER CONCRETE CHANNELS

POLY FLY 100 Low

(AISI 304 stainless steel edge rail)

Grating width 150 mm

Polymer concrete channel with galvanised edge rails complying with the UNI EN 1433 standard. The channels are sold exclusively in complete pallets and together with the gratings.

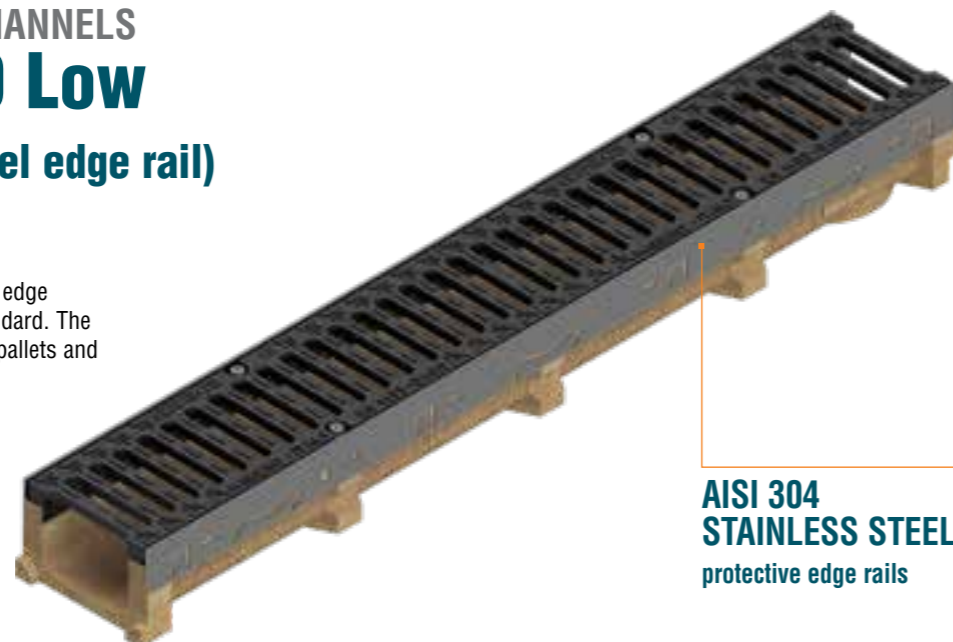

Poly Fly 100 Low channel dimensions

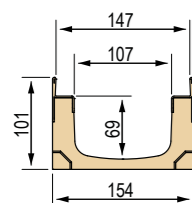

Available gratings

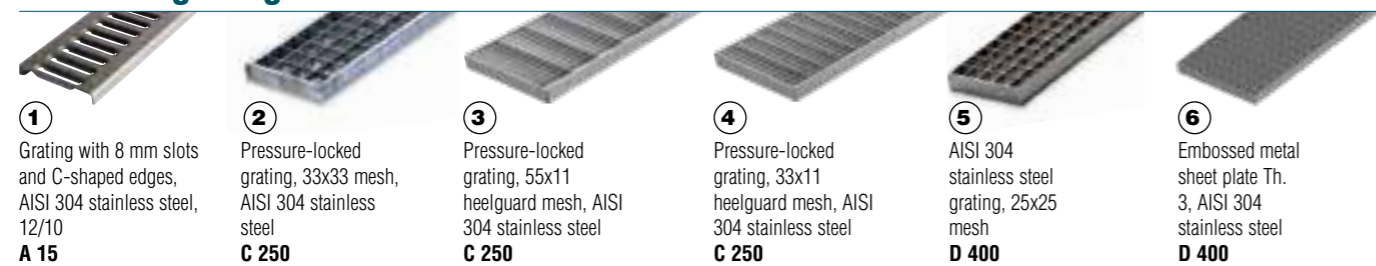

Poly Fly 100 Low channel (AISI 304 stainless steel edge rail) complete with grating - Length 1,000 mm

WITH AISI 304 STAINLESS STEEL PROTECTIVE EDGE RAIL

Channel L mm	Code	Grating	Description of the channel assembled with the grating complete with accessories	Weight kg	Load class
1,000	4G0DSLCL	①	Channel complete with AISI 304 stainless steel press-formed grating 12/10 with C-shaped edges	13.04	A 15
	4G0DSX1	②	Channel complete with pressure-locked grating with edging, 20x2-10x2 33x33, AISI 304 stainless steel	14.77	
	4G0DSX2	③	Channel complete with pressure-locked grating with edging, 20x2-10x2 55x11 heelguard mesh, AISI 304 stainless steel	15.02	
	4G0DSX3	④	Channel complete with pressure-locked grating with edging, 20x2-10x2 33x11 heelguard mesh, AISI 304 stainless steel	15.82	
	4G0DSX4	⑤	Channel complete with pressure-locked grating with edging, 20x3-10x2 25x25, AISI 304 stainless steel	15.58	D 400
	4G0DSP1	⑥	Channel complete with embossed metal sheet solid plate Th. 3, AISI 304 stainless steel, reinforced	21.47	

Poly Fly 100 Low channel (AISI 304 stainless steel edge rail) accessories

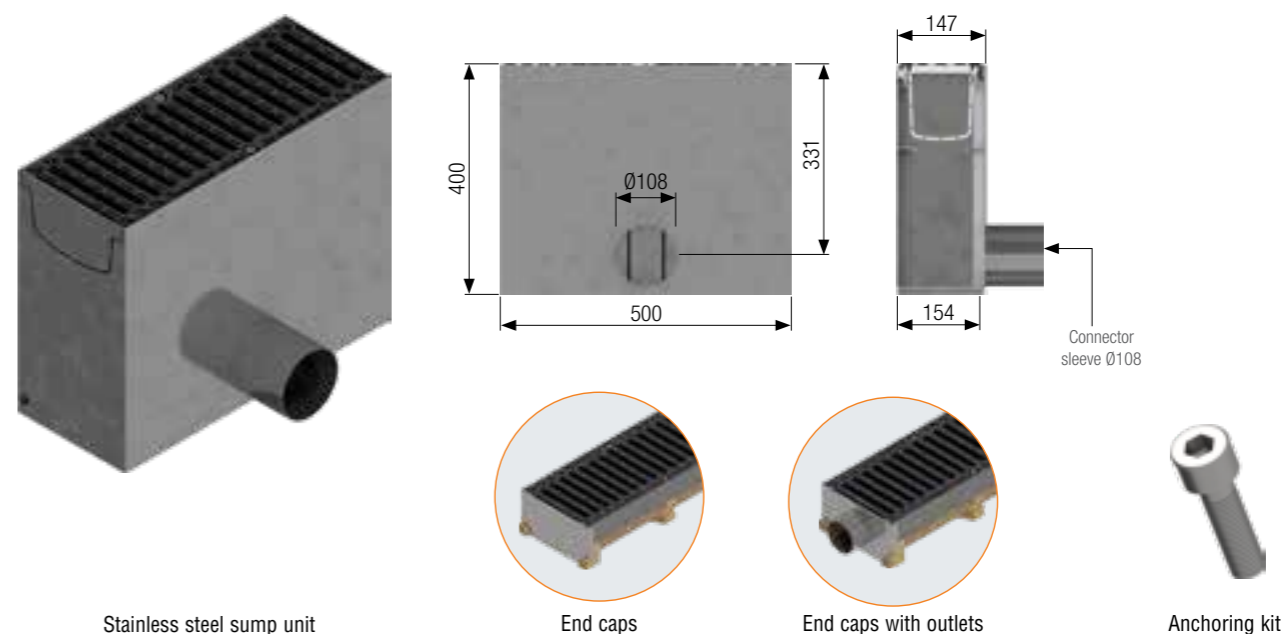

Poly Fly 100 Low AISI 304 stainless steel sump unit complete with grating - Length 500 mm

Sump unit L mm	Code	Grating	Description of the sump unit assembled with the grating complete with accessories	Weight kg	Load class
500	4G03PILCI	①	Sump unit complete with AISI 304 stainless steel press-formed metal sheet grating 12/10 with C-shaped edges	30.91	A 15
	4G03PIX1	②	Sump unit complete with pressure-locked grating with C-shaped edges, 20x2-10x2 33x33, AISI 304 stainless steel	31.78	
	4G03PIX2	③	Sump unit complete with pressure-locked grating with C-shaped edges, 20x2-10x2 55x11 heelguard mesh, AISI 304 stainless steel	31.90	C 250
	4G03PIX3	④	Sump unit complete with pressure-locked grating with C-shaped edges, 20x2-10x2 33x11 heelguard mesh, AISI 304 stainless steel	32.30	
	4G03PIX4	⑤	Sump unit complete with pressure-locked grating with edging, 20x3-10x2 25x25, AISI 304 stainless steel	32.18	D 400
	4G03PIPI	⑥	Sump unit complete with embossed metal sheet solid plate Th. 3, AISI 304 stainless steel, reinforced	35.13	

Poly Fly 100 Low AISI 304 stainless steel sump unit without grating and accessories

Code	Description	Weight kg
4G03PI	AISI 304 stainless steel sump unit L 500 mm	14.23
4G0DTI	AISI 304 stainless steel sheet end cap, thickness 15/10	0.20
4G0DRI	AISI 304 stainless steel sheet end cap with outlet, thickness 15/10 Ø60 mm	0.48
4D00K	Anchoring kit for galvanised and AISI 304 stainless steel gratings (for gratings 2 - 5)	0.02
4D00A	Anchoring kit for AISI 304 stainless steel heelguard gratings (for gratings 3 - 4)	0.02
4D00P	Anchoring kit for AISI 304 stainless steel plates (for plate 6)	0.02

Poly Fly 100 Low channel (AISI 304 stainless steel edge rail) without grating - Length 1,000 mm

Channel L mm	Code	Description	Water passage mm	Run-off section cm ²	Weight kg	Pieces pallet
1,000	4G0DS	Poly Fly 100 Low polymer concrete channel with AISI 304 stainless steel protective edge rail	107	70	11.86	78

POLYMER CONCRETE CHANNELS POLY FLY 100 Low WITH SPECIAL COVER

Grating width 150 mm

Polymer concrete channel with stainless steel edge rails complying with the UNI EN 1433 standard. The channels are sold exclusively in complete pallets and together with the gratings.

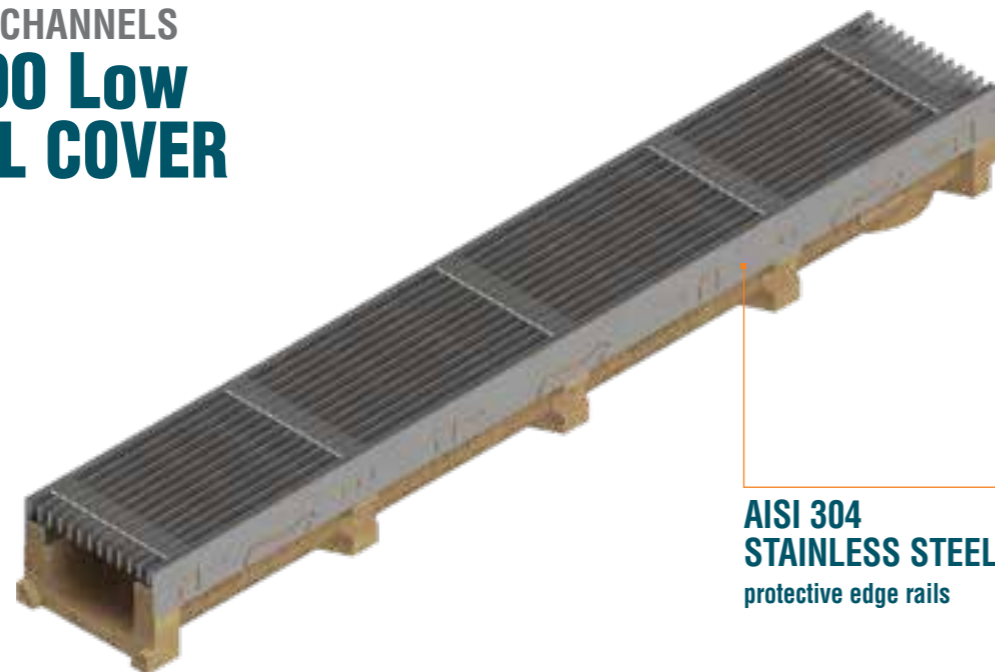

AISI 304 STAINLESS STEEL
protective edge rails

Poly Fly 100 Low channel dimensions

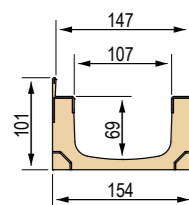

Available gratings

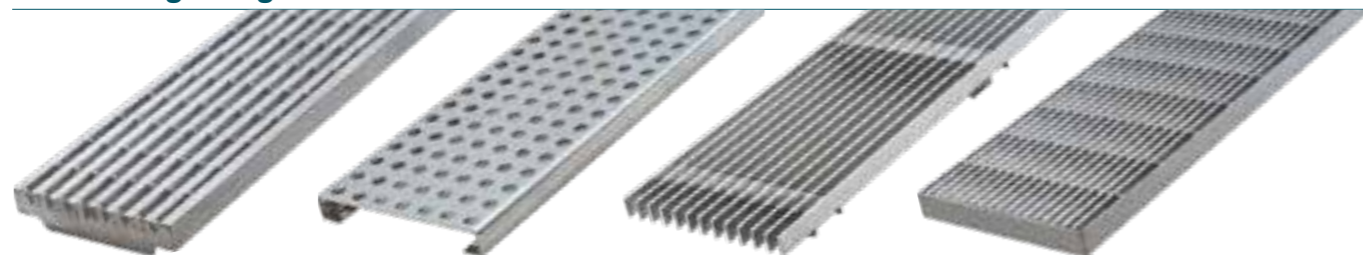

① "HORIZON" grating
B 125

② "MOON" grating
A 15

③ "METRÒ" grating
A 15

④ "DOLOMITES" grating
A 15

Poly Fly 100 Low channel complete with grating - Length 1,000 mm

WITH AISI 304 STAINLESS STEEL PROTECTIVE EDGE RAILS

Channel L mm	Code	Grating	Description of the channel assembled with the grating complete with accessories	Weight kg	Load class
1,000	4G0DSD1	①	Channel complete with "HORIZON" model AISI 304 stainless steel grating with U-shaped longitudinal edge rails, heelguard 6 mm slots, self-locking	15.42	B 125
	4G0DSD2	②	Channel complete with "MOON" model AISI 304 stainless steel grating, Th. 12/10 metal sheet, Ø10 holes, self-locking	13.42	A 15
	4G0DSD3	③	Channel complete with "METRÒ" model AISI 304 stainless steel grating, with longitudinal 15x3 plates, self-locking	14.92	
	4G0DSD4	④	Channel complete with "DOLOMITES" model AISI 304 stainless steel grating, with triangular edge rails, self-locking	16.17	

Accessories for Poly Fly 100 Low channel with Special cover

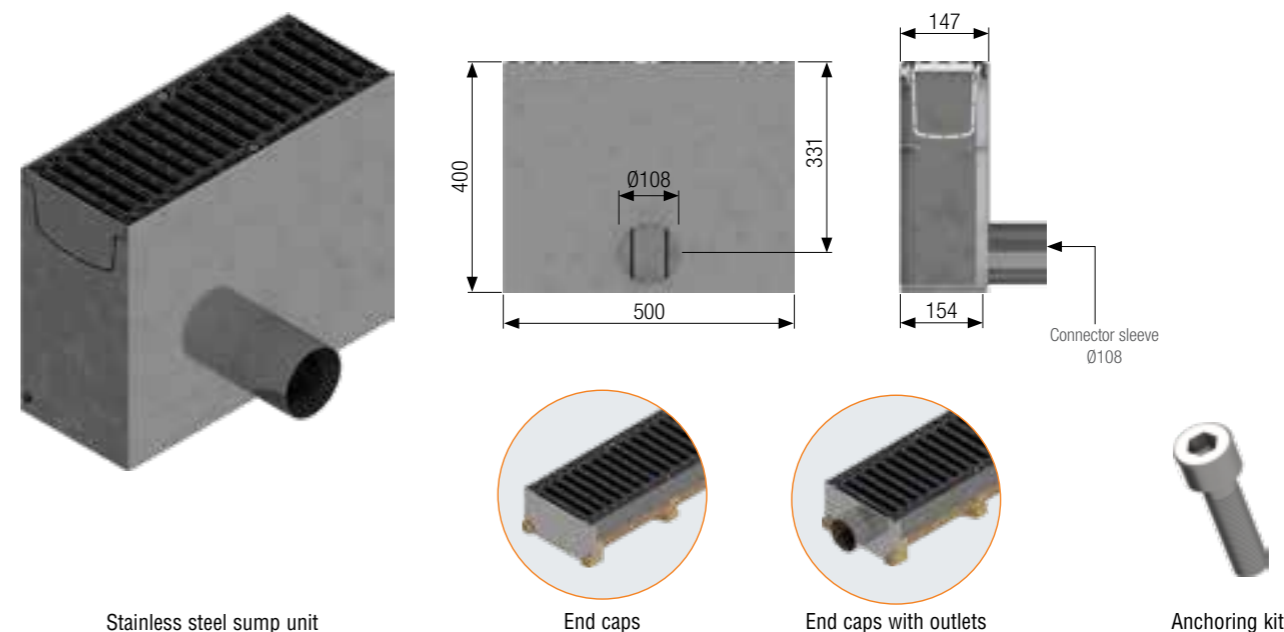

Stainless steel sump unit

End caps

End caps with outlets

Anchoring kit

Poly Fly 100 Low AISI 304 stainless steel sump unit complete with grating - Length 500 mm

Sump unit L mm	Code	Grating	Description of the sump unit assembled with the grating complete with accessories	Weight kg	Load class
500	4G03PID1	①	Sump unit complete with "HORIZON" model AISI 304 stainless steel grating with U-shaped longitudinal edge rails, heelguard 6 mm slots, self-locking	32.10	B 125
	4G03PID2	②	Sump unit complete with "MOON" model AISI 304 stainless steel grating, Th. 12/10 metal sheet, Ø10 holes, self-locking	31.10	A 15
	4G03PID3	③	Sump unit complete with "METRÒ" model AISI 304 stainless steel grating, with longitudinal 15x3 plates, self-locking	31.85	
	4G03PID4	④	Sump unit complete with "DOLOMITES" model AISI 304 stainless steel grating, with triangular edge rails, self-locking	31.63	

Poly Fly 100 Low AISI 304 stainless steel sump unit without grating and accessories

Code	Description	Weight kg
4G03PI	AISI 304 stainless steel sump unit L 500 mm	14.23
4G0DTI	AISI 304 stainless steel sheet end cap, thickness 15/10	0.20
4G0DR1	AISI 304 stainless steel sheet end cap with outlet, thickness 15/10, Ø60 mm	0.48

Poly Fly 100 Low channel without grating - Length 1,000 mm

Channel L mm	Code	Description	Water passage mm	Run-off section cm ²	Weight kg	Pieces pallet
1,000	4G0DS	Poly Fly 100 Low polymer concrete channel with AISI 304 stainless steel edge rail	107	70	11.86	78

POLYMER CONCRETE CHANNELS

POLY FLY 100 Low WITH THIN COVER

CENTRAL SLOT

Polymer concrete channel with galvanised or stainless steel edge rails complying with the UNI EN 1433 standard. The channels are sold exclusively in complete pallets and together with the gratings.

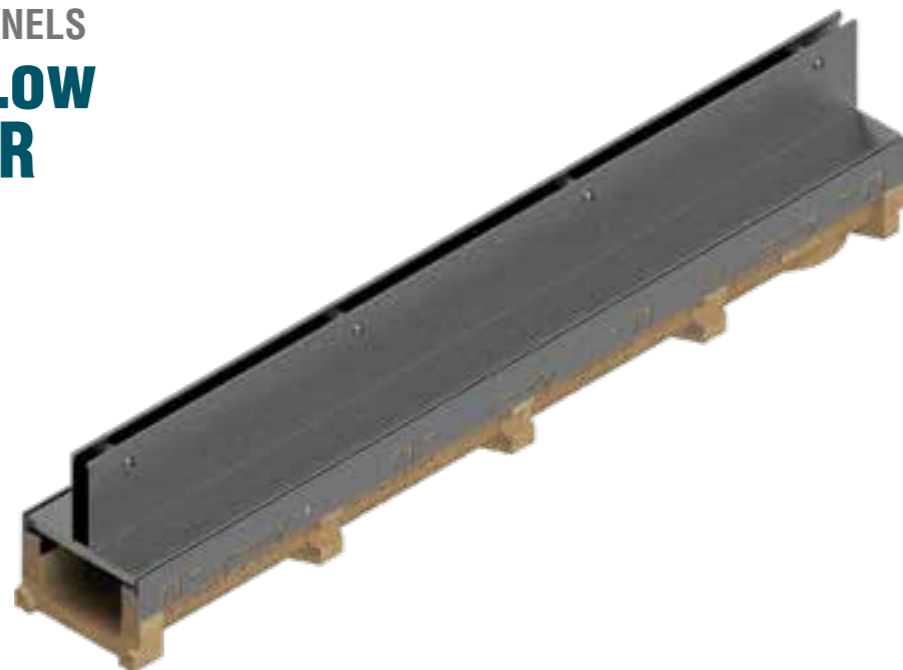

Poly Fly 100 Low channel dimensions

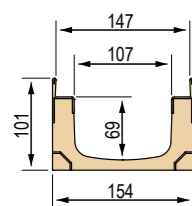

Available Thin covers

N.B.: available on request with 10 mm heelguard slot and in AISI 316 stainless steel

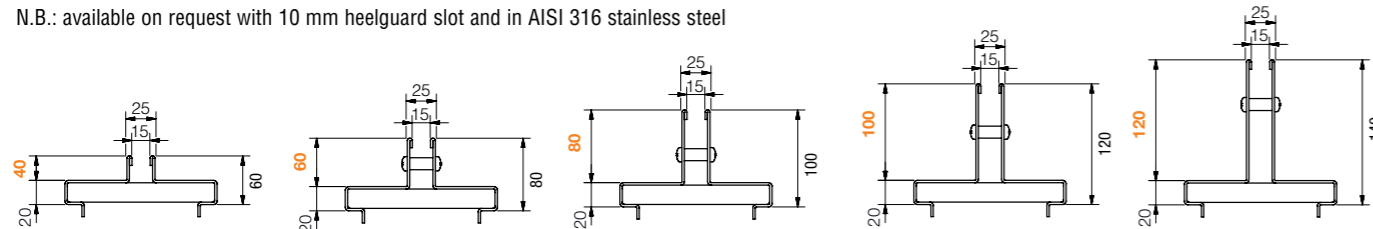

Poly Fly 100 Low channel without grating - Length 1,000 / 500 mm

Channel L mm	Code	Description	Water passage mm	Run-off section cm ²	Weight kg	Pieces pallet
1,000	4G0CS	Poly Fly 100 Low polymer concrete channel with galvanised protective edge rail	107	70	14.14	loose
	4G0DS	Poly Fly 100 Low polymer concrete channel with AISI 304 stainless steel edge rail	107	70	14.52	loose

Galvanised steel or AISI 304 stainless steel Poly Fly 100 Low sump unit without grating

Sump unit L mm	Code	Description	Weight kg
500	4G02PZ	Galvanised steel sump unit L 500 mm	14.23
	4G03PI	AISI 304 stainless steel sump unit L 500 mm	14.23



Thin covers with central slot - Slot width 15 mm

GALVANISED

Cover L mm	Code	Description	Slot height mm	Weight kg	Load class
1,000	4G02T0	Thin central cover, hot-dip galvanised, Th. 20/10	40	5.28	C 250
	4G02T	Thin central cover, hot-dip galvanised, Th. 20/10	60	5.91	
	4G02T1	Thin central cover, hot-dip galvanised, Th. 20/10	80	6.54	D 400
	4G02T2	Thin central cover, hot-dip galvanised, Th. 20/10	100	7.17	
	4G02T3	Thin central cover, hot-dip galvanised, Th. 20/10	120	7.29	
500	4G05T0	Thin central cover, hot-dip galvanised, Th. 20/10	40	2.63	C 250
	4G05T	Thin central cover, hot-dip galvanised, Th. 20/10	60	2.95	
	4G05T1	Thin central cover, hot-dip galvanised, Th. 20/10	80	3.27	D 400
	4G05T2	Thin central cover, hot-dip galvanised, Th. 20/10	100	3.58	
	4G05T3	Thin central cover, hot-dip galvanised, Th. 20/10	120	3.90	

N.B.: the Thin cover is supplied loose

AISI 304 STAINLESS STEEL

Cover L mm	Code	Description	Slot height mm	Weight kg	Load class
1,000	4G03I0	Thin central cover made of AISI 304 stainless steel Th. 20/10	40	5.28	C 250
	4G03I	Thin central cover made of AISI 304 stainless steel Th. 20/10	60	5.91	
	4G03I1	Thin central cover made of AISI 304 stainless steel Th. 20/10	80	6.54	D 400
	4G03I2	Thin central cover made of AISI 304 stainless steel Th. 20/10	100	7.17	
	4G03I3	Thin central cover made of AISI 304 stainless steel Th. 20/10	120	7.29	
500	4G05I0	Thin central cover made of AISI 304 stainless steel Th. 20/10	40	2.63	C 250
	4G05I	Thin central cover made of AISI 304 stainless steel Th. 20/10	60	2.95	
	4G05I1	Thin central cover made of AISI 304 stainless steel Th. 20/10	80	3.27	D 400
	4G05I2	Thin central cover made of AISI 304 stainless steel Th. 20/10	100	3.58	
	4G05I3	Thin central cover made of AISI 304 stainless steel Th. 20/10	120	3.90	

N.B.: the Thin cover is supplied loose



Inspection buckets for Thin covers with central slot - Slot width 15 mm

GALVANISED

Bucket L mm	Code	Description	Slot height mm	Weight kg	Load class
500	4G02V0	Inspection bucket for galvanised Thin central cover	40	3.97	C 250
	4G02V	Inspection bucket for galvanised Thin central cover	60	4.72	
	4G02V1	Inspection bucket for galvanised Thin central cover	80	5.46	D 400
	4G02V2	Inspection bucket for galvanised Thin central cover	100	6.20	
	4G02V3	Inspection bucket for galvanised Thin central cover	120	6.94	

N.B.: the Thin bucket is supplied loose

AISI 304 STAINLESS STEEL

Bucket L mm	Code	Description	Slot height mm	Weight kg	Load class
500	4G03V0	Inspection bucket for Thin central cover made of AISI 304 stainless steel	40	3.97	C 250
	4G03V	Inspection bucket for Thin central cover made of AISI 304 stainless steel	60	4.72	
	4G03V1	Inspection bucket for Thin central cover made of AISI 304 stainless steel	80	5.46	D 400
	4G03V2	Inspection bucket for Thin central cover made of AISI 304 stainless steel	100	6.20	
	4G03V3	Inspection bucket for Thin central cover made of AISI 304 stainless steel	120	6.94	

N.B.: the Thin bucket is supplied loose

POLYMER CONCRETE CHANNELS

POLY FLY 100 Low WITH THIN COVER

SIDE SLOT

Polymer concrete channel with galvanised or stainless steel edge rails complying with the UNI EN 1433 standard. The channels are sold exclusively in complete pallets and together with the gratings.

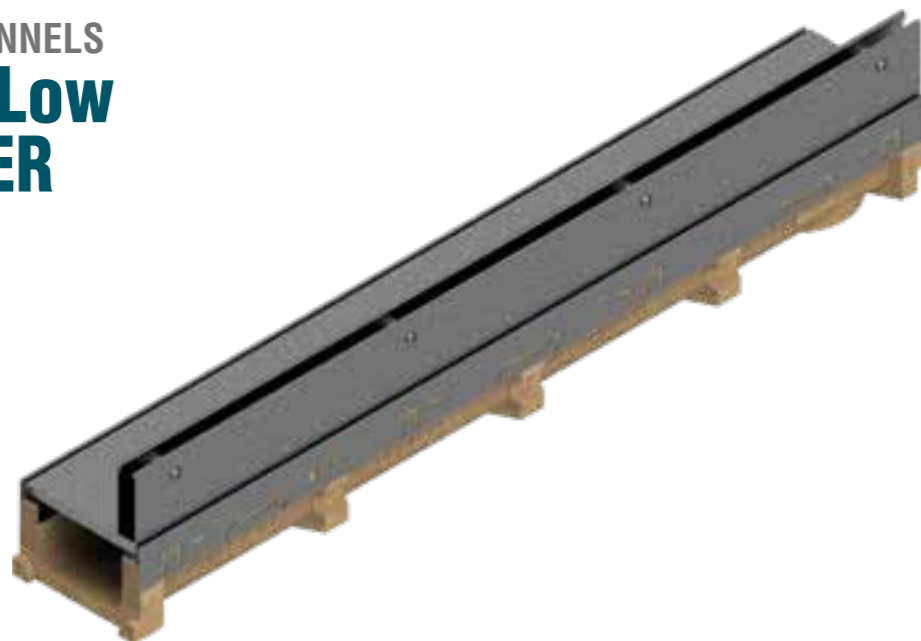

Poly Fly 100 Low channel dimensions

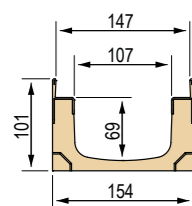

Available Thin covers

N.B.: available on request with 10 mm heelguard slot and in AISI 316 stainless steel

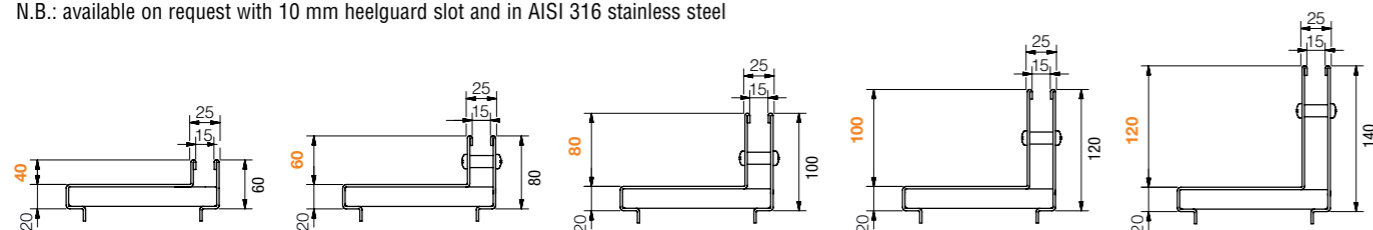

Poly Fly 100 Low channel without grating - Length 1,000 / 500 mm

Channel L mm	Code	Description	Water passage mm	Run-off section cm ²	Weight kg	Pieces pallet
1,000	4G0CS	Poly Fly 100 Low polymer concrete channel with galvanised protective edge rail	107	70	14.14	loose
	4G0DS	Poly Fly 100 Low polymer concrete channel with AISI 304 stainless steel edge rail	107	70	14.52	loose

Galvanised steel or AISI 304 stainless steel Poly Fly 100 Low sump unit without grating

Sump unit L mm	Code	Description	Weight kg
500	4G02PZ	Galvanised steel sump unit L 500 mm	14.23
	4G03PI	AISI 304 stainless steel sump unit L 500 mm	14.23



Thin covers with side slot - Slot width 15 mm

GALVANISED

Cover L mm	Code	Description	Slot height mm	Weight kg	Load class
1,000	4G02L0	Thin side cover, hot-dip galvanised, Th. 20/10	40	5.28	C 250
	4G02L	Thin side cover, hot-dip galvanised, Th. 20/10	60	5.91	
	4G02L1	Thin side cover, hot-dip galvanised, Th. 20/10	80	6.54	D 400
	4G02L2	Thin side cover, hot-dip galvanised, Th. 20/10	100	7.17	
	4G02L3	Thin side cover, hot-dip galvanised, Th. 20/10	120	7.29	
500	4G05L0	Thin side cover, hot-dip galvanised, Th. 20/10	40	2.63	C 250
	4G05L	Thin side cover, hot-dip galvanised, Th. 20/10	60	2.95	
	4G05L1	Thin side cover, hot-dip galvanised, Th. 20/10	80	3.27	D 400
	4G05L2	Thin side cover, hot-dip galvanised, Th. 20/10	100	3.58	
	4G05L3	Thin side cover, hot-dip galvanised, Th. 20/10	120	3.90	

N.B.: the Thin cover is supplied loose

AISI 304 STAINLESS STEEL

Cover L mm	Code	Description	Slot height mm	Weight kg	Load class
1,000	4G03IL0	Thin side cover made of AISI 304 stainless steel Th. 20/10	40	5.28	C 250
	4G03IL	Thin side cover made of AISI 304 stainless steel Th. 20/10	60	5.91	
	4G03IL1	Thin side cover made of AISI 304 stainless steel Th. 20/10	80	6.54	D 400
	4G03IL2	Thin side cover made of AISI 304 stainless steel Th. 20/10	100	7.17	
	4G03IL3	Thin side cover made of AISI 304 stainless steel Th. 20/10	120	7.29	
500	4G05IL0	Thin side cover made of AISI 304 stainless steel Th. 20/10	40	2.63	C 250
	4G05IL	Thin side cover made of AISI 304 stainless steel Th. 20/10	60	2.95	
	4G05IL1	Thin side cover made of AISI 304 stainless steel Th. 20/10	80	3.27	D 400
	4G05IL2	Thin side cover made of AISI 304 stainless steel Th. 20/10	100	3.58	
	4G05IL3	Thin side cover made of AISI 304 stainless steel Th. 20/10	120	3.90	

N.B.: the Thin cover is supplied loose



Inspection buckets for Thin covers with side slot - Slot width 15 mm

GALVANISED

Bucket L mm	Code	Description	Slot height mm	Weight kg	Load class
500	4G02VL0	Inspection bucket for galvanised Thin side cover	40	3.97	C 250
	4G02VL	Inspection bucket for galvanised Thin side cover	60	4.72	
	4G02VL1	Inspection bucket for galvanised Thin side cover	80	5.46	D 400
	4G02VL2	Inspection bucket for galvanised Thin side cover	100	6.20	
	4G02VL3	Inspection bucket for galvanised Thin side cover	120	6.94	

N.B.: the Thin bucket is supplied loose

AISI 304 STAINLESS STEEL

Bucket L mm	Code	Description	Slot height mm	Weight kg	Load class
500	4G05VL10	Inspection bucket for Thin side cover made of AISI 304 stainless steel	40	3.97	C 250
	4G05VLI	Inspection bucket for Thin side cover made of AISI 304 stainless steel	60	4.72	
	4G05VL11	Inspection bucket for Thin side cover made of AISI 304 stainless steel	80	5.46	D 400
	4G05VL12	Inspection bucket for Thin side cover made of AISI 304 stainless steel	100	6.20	
	4G05VL13	Inspection bucket for Thin side cover made of AISI 304 stainless steel	120	6.94	

N.B.: the Thin bucket is supplied loose

POLYMER CONCRETE CHANNELS

POLY FLY 100 WITH SLOPE

(galvanised edge rail)

Grating width 150 mm

Polymer concrete channel with galvanised edge rails complying with the UNI EN 1433 standard.

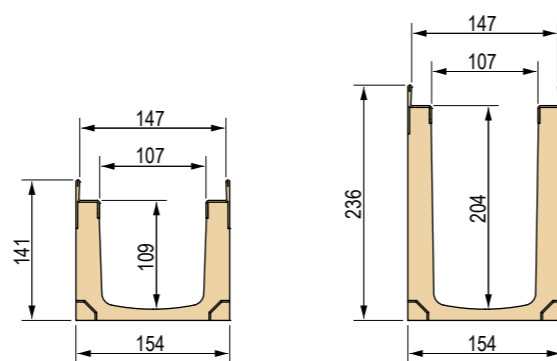
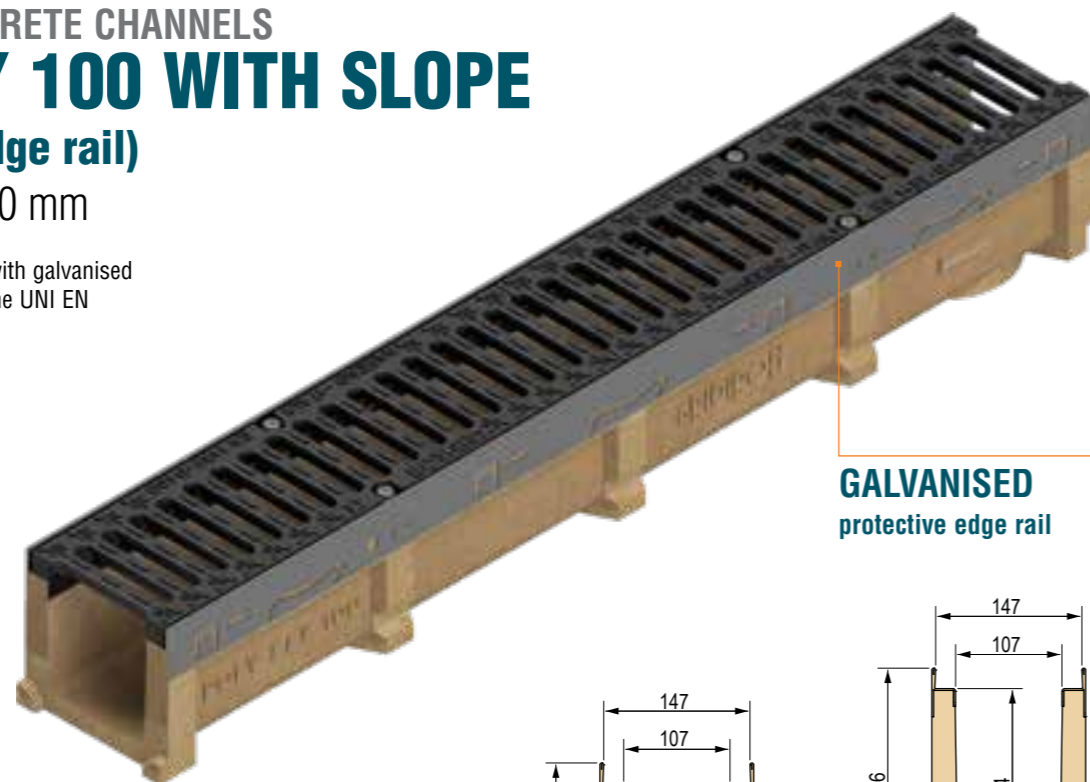

Channel L mm	Code	Description	Slope	Initial H mm	Final H mm	Weight kg
1,000	4G02S01	Channel no. 1	0.5%	141	146	14.14
	4G02S02	Channel no. 2	0.5%	146	151	14.63
	4G02S03	Channel no. 3	0.5%	151	156	15.13
	4G02S04	Channel no. 4	0.5%	156	161	15.63
	4G02S05	Channel no. 5	0.5%	161	166	16.13
	4G02S06	Channel no. 6	0.5%	166	171	16.64
	4G02S07	Channel no. 7	0.5%	171	176	17.14
	4G02S08	Channel no. 8	0.5%	176	181	17.64
	4G02S09	Channel no. 9	0.5%	181	186	18.14
	4G02S10	Channel no. 10	0.5%	186	191	18.64
	4G02S11	Channel no. 11	0.5%	191	196	19.14
	4G02S12	Channel no. 12	0.5%	196	201	19.64
	4G02S13	Channel no. 13	0.5%	201	206	20.15
	4G02S14	Channel no. 14	0.5%	206	211	20.65
	4G02S15	Channel no. 15	0.5%	211	216	21.15
	4G02S16	Channel no. 16	0.5%	216	221	21.65
	4G02S17	Channel no. 17	0.5%	221	226	22.15
	4G02S18	Channel no. 18	0.5%	226	231	22.65
	4G02S19	Channel no. 19	0.5%	231	236	23.15
	4G02S20	Channel no. 20	0.5%	236	241	23.66

Available gratings



Grating L mm	Code	Grating	Description of gratings complete with accessories	Weight kg	Load class
1,000	4D02LC	①	Galvanised press-formed metal sheet grating 12/10 with C-shaped edges	1.82	A 15
	4RP0GP	②	Pressure-locked grating with C-shaped edges, 20x2-10x2 33x33, hot-dip galvanised	2.54	C 250
	4RP0GPB	③	Pressure-locked grating with C-shaped edges, 20x2-10x2 55x11, heelguard mesh, hot-dip galvanised	3.24	
	4RP0GPA	④	Pressure-locked grating with C-shaped edges, 20x2-10x2 33x11, heelguard mesh, hot-dip galvanised	3.81	
500	4D02GS	⑤	GJS500-7 ductile iron gratings	3.93	D 400
	4D02GSA	⑥	GJS500-7 ductile iron heelguard gratings	4.09	
1,000	4D02P	⑦	Embossed metal sheet solid plate Th. 3, reinforced and hot-dip galvanised	10.25	

Accessories for Poly Fly 100 with slope channel

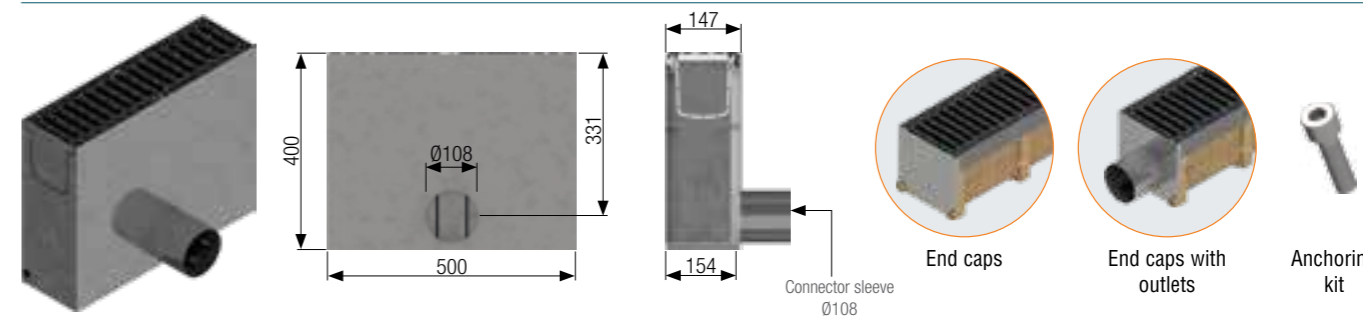

Poly Fly 100 with slope galvanised steel sump unit complete with grating - Length 500 mm

Sump unit L mm	Code	Grating	Description of the sump unit assembled with the grating complete with accessories	Weight kg	Load class
500	4G02PZLC	①	Sump unit complete with galvanised press-formed metal sheet grating 12/10 with C-shaped edges	30.47	A 15
	4G02PZG1	②	Sump unit complete with pressure-locked grating with C-shaped edges, 20x2-10x2 33x33, hot-dip galvanised	31.27	C 250
	4G02PZG2	③	Sump unit complete with pressure-locked grating with C-shaped edges, 20x2-10x2 55x11 heelguard mesh, hot-dip galvanised	31.62	
	4G02PZG3	④	Sump unit complete with pressure-locked grating with C-shaped edges, 20x2-10x2 33x11 heelguard mesh, hot-dip galvanised	31.91	
	4G02PZGS	⑤	Sump unit complete with GJS500-7 ductile iron grating	33.93	D 400
	4G02PZGSA	⑥	Sump unit complete with GJS500-7 ductile iron heelguard grating	34.09	
	4G02PZP	⑦	Sump unit complete with embossed metal sheet solid plate Th. 3, reinforced and hot-dip galvanised	35.13	

Poly Fly 100 with slope galvanised steel sump unit without grating and accessories

Code	Description	Weight kg
4G02PZ	Galvanised steel sump unit L 500 mm	14.23
4G02TI	AISI 304 stainless steel sheet end cap, thickness 15/10	0.30
4G02RI	AISI 304 stainless steel sheet end cap with outlet, thickness 15/10 Ø108 mm	0.52
4D00K	Anchoring kit for galvanised and AISI 304 stainless steel gratings (for gratings 2 - 3 - 4)	0.02
4D00V	Anchoring kit for ductile iron gratings (for gratings 5 - 6)	0.02
4D00P	Anchoring kit for galvanised/AISI 304 stainless steel plates (for plate 7)	0.02

POLYMER CONCRETE CHANNELS

POLY FLY 100 WITH SLOPE

(AISI 304 stainless steel edge rail)

Grating width 150 mm

Polymer concrete channel with AISI 304 stainless steel edge rails complying with the UNI EN 1433 standard.

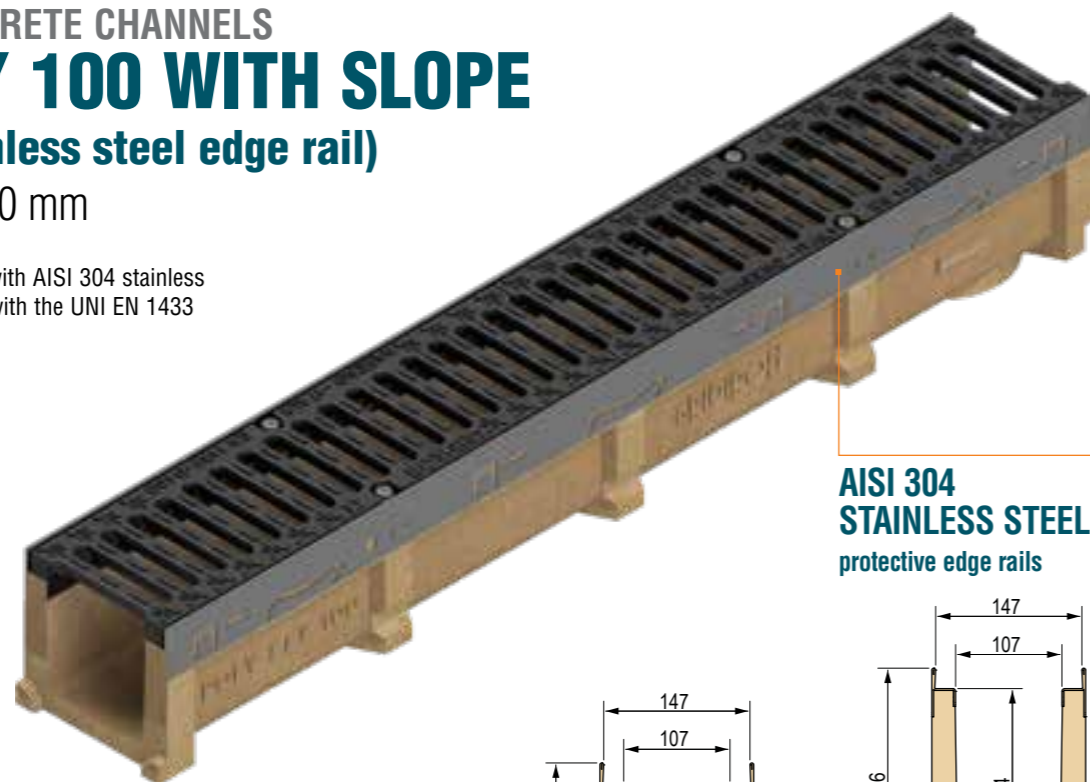

AISI 304 STAINLESS STEEL
protective edge rails

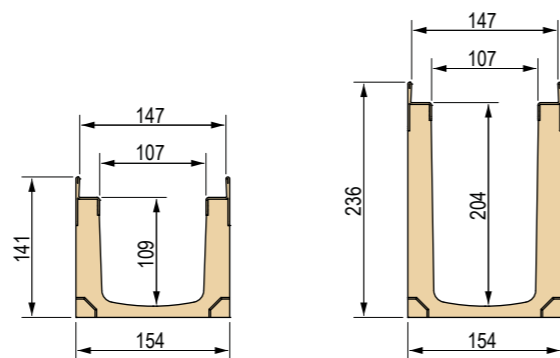

Channel L mm	Code	Description	Slope	Initial H mm	Final H mm	Weight kg
1,000	4G03S01	Channel no. 1	0.5%	141	146	14.14
	4G03S02	Channel no. 2	0.5%	146	151	14.63
	4G03S03	Channel no. 3	0.5%	151	156	15.13
	4G03S04	Channel no. 4	0.5%	156	161	15.63
	4G03S05	Channel no. 5	0.5%	161	166	16.13
	4G03S06	Channel no. 6	0.5%	166	171	16.64
	4G03S07	Channel no. 7	0.5%	171	176	17.14
	4G03S08	Channel no. 8	0.5%	176	181	17.64
	4G03S09	Channel no. 9	0.5%	181	186	18.14
	4G03S10	Channel no. 10	0.5%	186	191	18.64
	4G03S11	Channel no. 11	0.5%	191	196	19.14
	4G03S12	Channel no. 12	0.5%	196	201	19.64
	4G03S13	Channel no. 13	0.5%	201	206	20.15
	4G03S14	Channel no. 14	0.5%	206	211	20.65
	4G03S15	Channel no. 15	0.5%	211	216	21.15
	4G03S16	Channel no. 16	0.5%	216	221	21.65
	4G03S17	Channel no. 17	0.5%	221	226	22.15
	4G03S18	Channel no. 18	0.5%	226	231	22.65
	4G03S19	Channel no. 19	0.5%	231	236	23.15
	4G03S20	Channel no. 20	0.5%	236	241	23.66

Available gratings

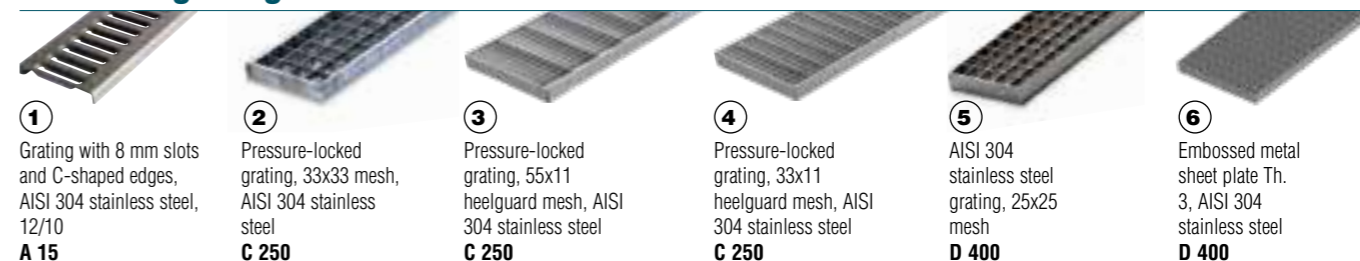

Grating L mm	Code	Grating	Description of gratings complete with accessories	Weight kg	Load class
1,000	4D01LCI	①	AISI 304 stainless steel press-formed metal sheet grating 12/10 with C-shaped edges	1.82	A 15
	4D03X1	②	Pressure-locked grating with C-shaped edges, 20x2-10x2 33x33, AISI 304 stainless steel	3.55	C 250
	4D03X2	③	Pressure-locked grating with C-shaped edges, 20x2-10x2 55x11, AISI 304 stainless steel	3.80	
	4D03X3	④	Pressure-locked grating with C-shaped edges, 20x2-10x2 33x11, AISI 304 stainless steel	4.60	
	4D03X4	⑤	Pressure-locked grating with C-shaped edges, 20x3-10x2 25x25, AISI 304 stainless steel	4.36	D 400
	4D01PI	⑥	Embossed metal sheet solid plate Th. 3, AISI 304 stainless steel	10.25	

Accessories for Poly Fly 100 with slope channel

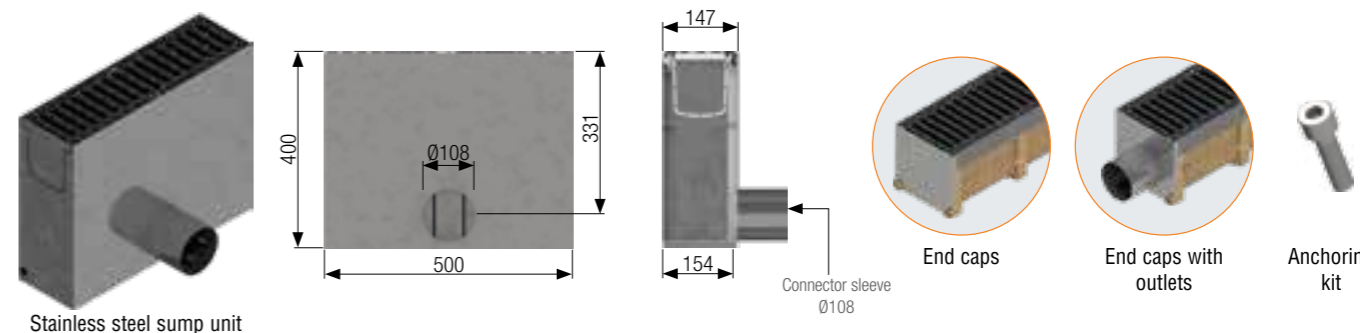

Poly Fly 100 with slope AISI 304 stainless steel sump unit complete with grating - Length 500 mm

Sump unit L mm	Code	Grating	Description of the sump unit assembled with the grating complete with accessories	Weight kg	Load class
500	4G03PILCI	①	Sump unit complete with AISI 304 stainless steel press-formed metal sheet grating 12/10 with C-shaped edges	30.91	A 15
	4G03PIX1	②	Sump unit complete with pressure-locked grating with edging, 20x2-10x2 33x33, AISI 304 stainless steel	31.78	C 250
	4G03PIX2	③	Sump unit complete with pressure-locked grating with edging, 20x2-10x2 55x11, heelguard mesh, AISI 304 stainless steel	31.90	
	4G03PIX3	④	Sump unit complete with pressure-locked grating with edging, 20x2-10x2 33x11, heelguard mesh, AISI 304 stainless steel	32.30	
	4G03PIX4	⑤	Sump unit complete with pressure-locked grating with edging, 20x3-10x2 25x25, AISI 304 stainless steel	32.18	D 400
	4G03PIPI	⑥	Sump unit complete with embossed metal sheet solid plate Th. 3, AISI 304 stainless steel, reinforced	35.13	

Poly Fly 100 with slope AISI 304 stainless steel sump unit without grating and accessories

Code	Description	Weight kg
4G03PI	AISI 304 stainless steel sump unit L 500 mm	14.23
4G02TI	AISI 304 stainless steel sheet end cap, thickness 15/10	0.30
4G02RI	AISI 304 stainless steel sheet end cap with outlet, thickness 15/10 Ø108 mm	0.52
4D00K	Anchoring kit for galvanised and AISI 304 stainless steel gratings (for gratings 2 - 5)	0.02
4D00A	Anchoring kit for AISI 304 stainless steel heelguard gratings (for gratings 3 - 4)	0.02
4D00P	Anchoring kit for galvanised/AISI 304 stainless steel plates (for plate 6)	0.02

POLYMER CONCRETE CHANNELS POLY FLY 100 WITH SLOPE WITH SPECIAL COVER

Grating width 150 mm

Stainless steel polymer concrete channel complying with the UNI EN 1433 standard.

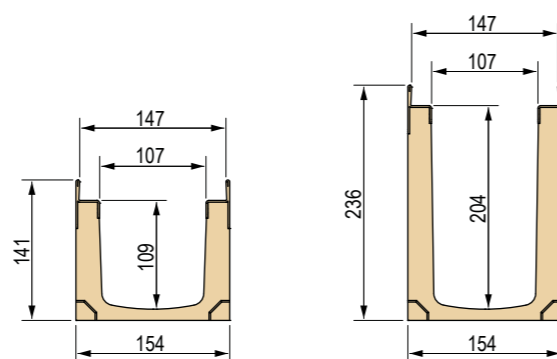
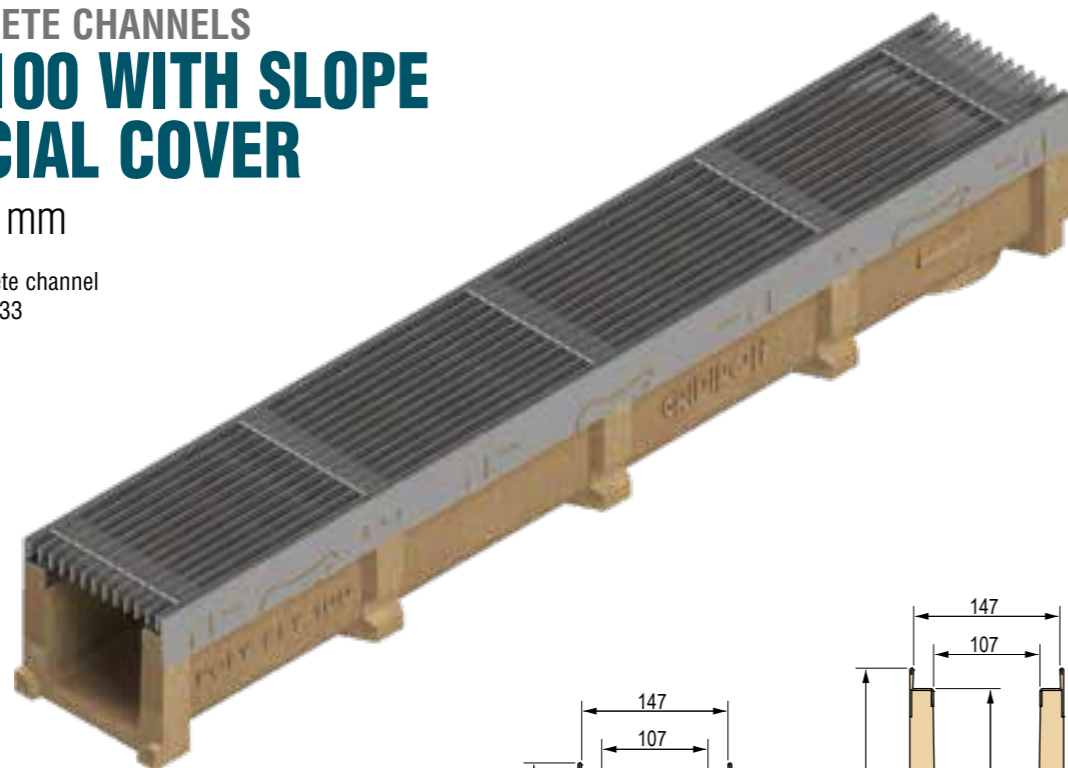

Channel L mm	Code	Description	Slope	Initial H mm	Final H mm	Weight kg
1,000	4G03S01	Channel no. 1	0.5%	141	146	14.14
	4G03S02	Channel no. 2	0.5%	146	151	14.63
	4G03S03	Channel no. 3	0.5%	151	156	15.13
	4G03S04	Channel no. 4	0.5%	156	161	15.63
	4G03S05	Channel no. 5	0.5%	161	166	16.13
	4G03S06	Channel no. 6	0.5%	166	171	16.64
	4G03S07	Channel no. 7	0.5%	171	176	17.14
	4G03S08	Channel no. 8	0.5%	176	181	17.64
	4G03S09	Channel no. 9	0.5%	181	186	18.14
	4G03S10	Channel no. 10	0.5%	186	191	18.64
	4G03S11	Channel no. 11	0.5%	191	196	19.14
	4G03S12	Channel no. 12	0.5%	196	201	19.64
	4G03S13	Channel no. 13	0.5%	201	206	20.15
	4G03S14	Channel no. 14	0.5%	206	211	20.65
	4G03S15	Channel no. 15	0.5%	211	216	21.15
	4G03S16	Channel no. 16	0.5%	216	221	21.65
	4G03S17	Channel no. 17	0.5%	221	226	22.15
	4G03S18	Channel no. 18	0.5%	226	231	22.65
	4G03S19	Channel no. 19	0.5%	231	236	23.15
	4G03S20	Channel no. 20	0.5%	236	241	23.66

Available gratings

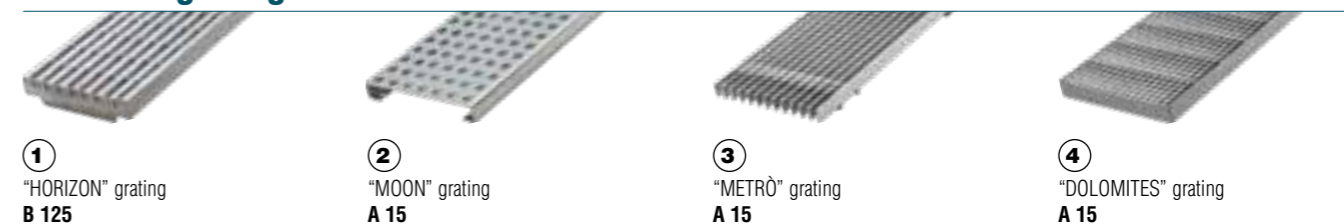

Grating L mm	Code	Grating	Description of gratings complete with accessories	Weight kg	Load class
1,000	4G03D1	①	"HORIZON" model AISI 304 stainless steel grating with U-shaped longitudinal edge rails, heelguard 6 mm slots, self-locking	3.57	B125
	4G03D2	②	"MOON" model AISI 304 stainless steel grating, Th. 12/10 metal sheet, Ø10 holes, self-locking	2.85	A 15
	4G03D3	③	"METRÒ" model AISI 304 stainless steel grating, with longitudinal 15x3 plates, self-locking	4.98	
	4G03D4	④	"DOLOMITES" model AISI 304 stainless steel grating, with triangular edge rails, self-locking	3.67	

Accessories for Poly Fly 100 with slope channel

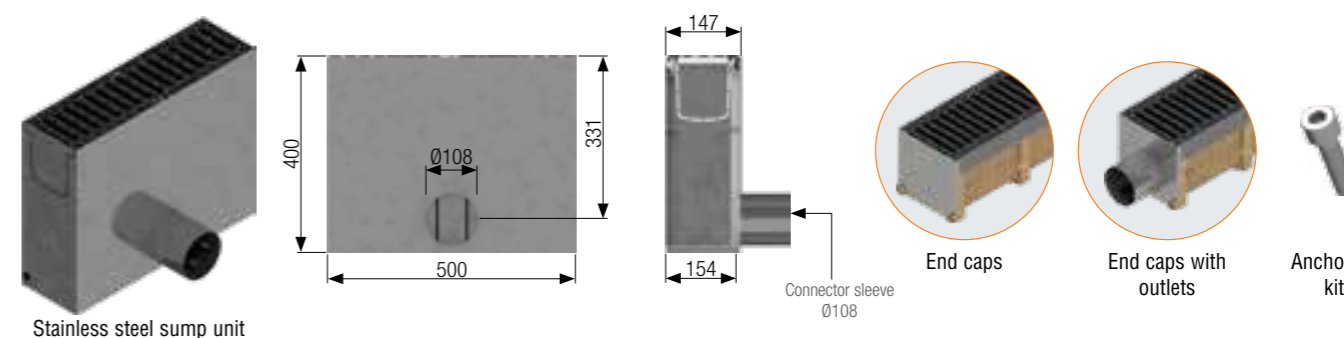

Poly Fly 100 with slope AISI 304 stainless steel sump unit complete with grating - Length 500 mm

Sump unit L mm	Code	Grating	Description of the sump unit assembled with the grating complete with accessories	Weight kg	Load class
500	4G03PID1	①	Sump unit complete with "HORIZON" model AISI 304 stainless steel grating with U-shaped longitudinal edge rails, heelguard 6 mm slots, self-locking	32.10	B 125
	4G03PID2	②	Sump unit complete with "MOON" model AISI 304 stainless steel grating, Th. 12/10 metal sheet, Ø10 holes, self-locking	31.10	A 15
	4G03PID3	③	Sump unit complete with "METRÒ" model AISI 304 stainless steel grating, with longitudinal 15x3 plates, self-locking	31.85	
	4G03PID4	④	Sump unit complete with "DOLOMITES" model AISI 304 stainless steel grating, with triangular edge rails, self-locking	31.63	

Poly Fly 100 with slope AISI 304 stainless steel sump unit without grating and accessories

Code	Description	Weight kg
4G03PI	AISI 304 stainless steel sump unit L 500 mm	14.23
4G02TI	AISI 304 stainless steel sheet end cap, thickness 15/10	0.30
4G02RI	AISI 304 stainless steel sheet end cap with outlet, thickness 15/10, Ø108 mm	0.52

POLYMER CONCRETE CHANNELS

POLY FLY 100 WITH SLOPE WITH THIN COVER (GALVANISED)

CENTRAL SLOT

Grating width 150 mm

Polymer concrete channel with galvanised edge rails complying with the UNI EN 1433 standard.

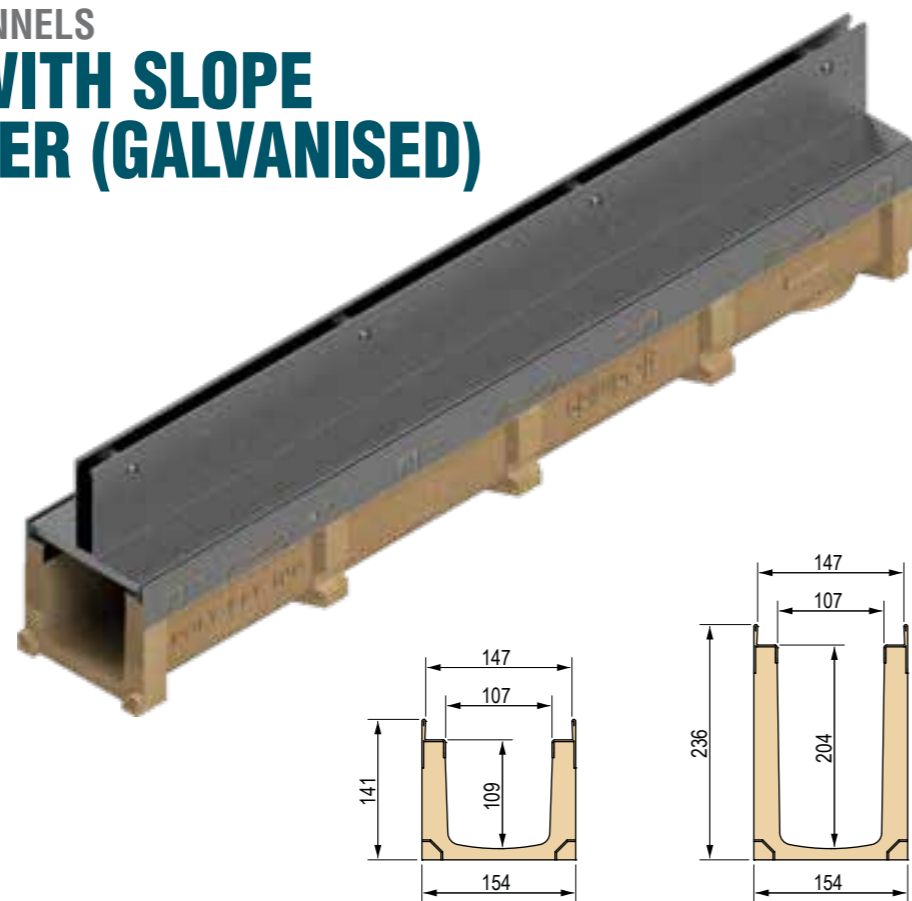

Channel L mm	Code	Description	Slope	Initial H mm	Final H mm	Weight kg
1,000	4G02S01	Channel no. 1	0.5%	141	146	14.14
	4G02S02	Channel no. 2	0.5%	146	151	14.63
	4G02S03	Channel no. 3	0.5%	151	156	15.13
	4G02S04	Channel no. 4	0.5%	156	161	15.63
	4G02S05	Channel no. 5	0.5%	161	166	16.13
	4G02S06	Channel no. 6	0.5%	166	171	16.64
	4G02S07	Channel no. 7	0.5%	171	176	17.14
	4G02S08	Channel no. 8	0.5%	176	181	17.64
	4G02S09	Channel no. 9	0.5%	181	186	18.14
	4G02S10	Channel no. 10	0.5%	186	191	18.64
	4G02S11	Channel no. 11	0.5%	191	196	19.14
	4G02S12	Channel no. 12	0.5%	196	201	19.64
	4G02S13	Channel no. 13	0.5%	201	206	20.15
	4G02S14	Channel no. 14	0.5%	206	211	20.65
	4G02S15	Channel no. 15	0.5%	211	216	21.15
	4G02S16	Channel no. 16	0.5%	216	221	21.65
	4G02S17	Channel no. 17	0.5%	221	226	22.15
	4G02S18	Channel no. 18	0.5%	226	231	22.65
	4G02S19	Channel no. 19	0.5%	231	236	23.15
	4G02S20	Channel no. 20	0.5%	236	241	23.66

Poly Fly 100 with slope galvanised steel sump unit without grating

Sump unit L mm	Code	Description	Weight kg
500	4G02PZ	Galvanised steel sump unit L 500 mm	14.23

Available Thin covers

N.B.: available on request with 10 mm heelguard slots

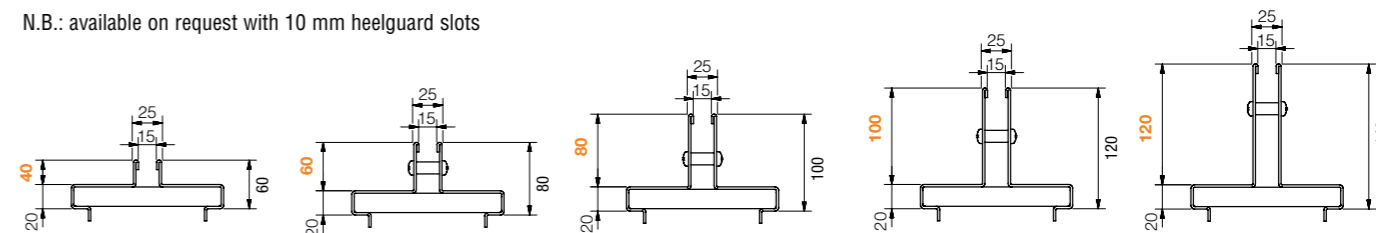

Thin covers with central slot - Slot width 15 mm

GALVANISED

Cover L mm	Code	Description	Slot height mm	Weight kg	Load class
1,000	4G02T0	Thin central cover, hot-dip galvanised, Th. 20/10	40	5.28	C 250
	4G02T	Thin central cover, hot-dip galvanised, Th. 20/10	60	5.91	
	4G02T1	Thin central cover, hot-dip galvanised, Th. 20/10	80	6.54	D 400
	4G02T2	Thin central cover, hot-dip galvanised, Th. 20/10	100	7.17	
	4G02T3	Thin central cover, hot-dip galvanised, Th. 20/10	120	7.29	
500	4G05T0	Thin central cover, hot-dip galvanised, Th. 20/10	40	2.63	C 250
	4G05T	Thin central cover, hot-dip galvanised, Th. 20/10	60	2.95	
	4G05T1	Thin central cover, hot-dip galvanised, Th. 20/10	80	3.27	D 400
	4G05T2	Thin central cover, hot-dip galvanised, Th. 20/10	100	3.58	
	4G05T3	Thin central cover, hot-dip galvanised, Th. 20/10	120	3.90	

N.B.: the Thin cover is supplied loose

Inspection buckets for Thin covers with central slot - Slot width 15 mm

GALVANISED

Bucket L mm	Code	Description	Slot height mm	Weight kg	Load class
500	4G02V0	Inspection bucket for galvanised Thin central cover	40	3.97	C 250
	4G02V	Inspection bucket for galvanised Thin central cover	60	4.72	
500	4G02V1	Inspection bucket for galvanised Thin central cover	80	5.46	D 400
	4G02V2	Inspection bucket for galvanised Thin central cover	100	6.20	
	4G02V3	Inspection bucket for galvanised Thin central cover	120	6.94	

N.B.: the Thin bucket is supplied loose

POLYMER CONCRETE CHANNELS

POLY FLY 100 WITH SLOPE WITH THIN COVER (GALVANISED)

SIDE SLOT

Grating width 150 mm

Polymer concrete channel with galvanised edge rails complying with the UNI EN 1433 standard.

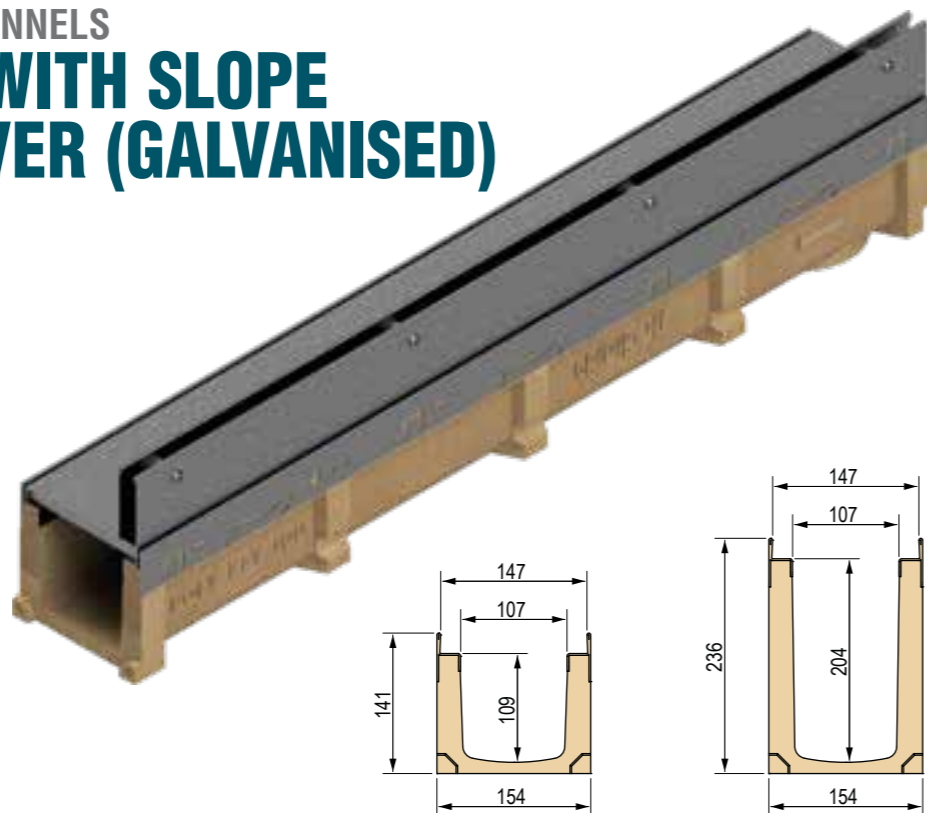

Channel L mm	Code	Description	Slope	Initial H mm	Final H mm	Weight kg
1,000	4G02S01	Channel no. 1	0.5%	141	146	14.14
	4G02S02	Channel no. 2	0.5%	146	151	14.63
	4G02S03	Channel no. 3	0.5%	151	156	15.13
	4G02S04	Channel no. 4	0.5%	156	161	15.63
	4G02S05	Channel no. 5	0.5%	161	166	16.13
	4G02S06	Channel no. 6	0.5%	166	171	16.64
	4G02S07	Channel no. 7	0.5%	171	176	17.14
	4G02S08	Channel no. 8	0.5%	176	181	17.64
	4G02S09	Channel no. 9	0.5%	181	186	18.14
	4G02S10	Channel no. 10	0.5%	186	191	18.64
	4G02S11	Channel no. 11	0.5%	191	196	19.14
	4G02S12	Channel no. 12	0.5%	196	201	19.64
	4G02S13	Channel no. 13	0.5%	201	206	20.15
	4G02S14	Channel no. 14	0.5%	206	211	20.65
	4G02S15	Channel no. 15	0.5%	211	216	21.15
	4G02S16	Channel no. 16	0.5%	216	221	21.65
	4G02S17	Channel no. 17	0.5%	221	226	22.15
	4G02S18	Channel no. 18	0.5%	226	231	22.65
	4G02S19	Channel no. 19	0.5%	231	236	23.15
	4G02S20	Channel no. 20	0.5%	236	241	23.66

Poly Fly 100 with slope galvanised steel sump unit without grating

Sump unit L mm	Code	Description	Weight kg
500	4G02PZ	Galvanised steel sump unit L 500 mm	14.23

Available Thin covers

N.B.: available on request with 10 mm heelguard slots.

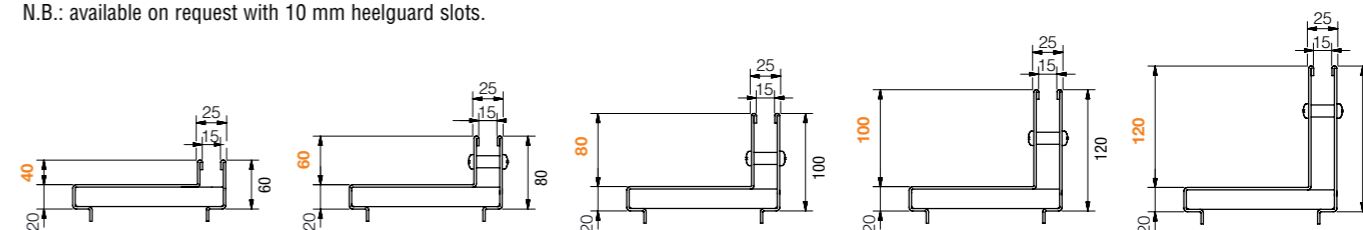

Thin covers with side slot - Slot width 15 mm

GALVANISED

Cover L mm	Code	Description	Slot height mm	Weight kg	Load class
1,000	4G02L0	Thin side cover, hot-dip galvanised, Th. 20/10	40	5.28	C 250
	4G02L	Thin side cover, hot-dip galvanised, Th. 20/10	60	5.91	
	4G02L1	Thin side cover, hot-dip galvanised, Th. 20/10	80	6.54	D 400
	4G02L2	Thin side cover, hot-dip galvanised, Th. 20/10	100	7.17	
	4G02L3	Thin side cover, hot-dip galvanised, Th. 20/10	120	7.29	
500	4G05L0	Thin side cover, hot-dip galvanised, Th. 20/10	40	2.63	C 250
	4G05L	Thin side cover, hot-dip galvanised, Th. 20/10	60	2.95	
	4G05L1	Thin side cover, hot-dip galvanised, Th. 20/10	80	3.27	D 400
	4G05L2	Thin side cover, hot-dip galvanised, Th. 20/10	100	3.58	
	4G05L3	Thin side cover, hot-dip galvanised, Th. 20/10	120	3.90	

N.B.: The Thin cover is supplied loose

Inspection buckets for Thin covers with side slot - Slot width 15 mm

GALVANISED

Bucket L mm	Code	Description	Slot height mm	Weight kg	Load class
500	4G02VL0	Inspection bucket for galvanised Thin side cover	40	3.97	C 250
	4G02VL	Inspection bucket for galvanised Thin side cover	60	4.72	
	4G02VL1	Inspection bucket for galvanised Thin side cover	80	5.46	D 400
	4G02VL2	Inspection bucket for galvanised Thin side cover	100	6.20	
	4G02VL3	Inspection bucket for galvanised Thin side cover	120	6.94	

N.B.: the Thin bucket is supplied loose

POLYMER CONCRETE CHANNELS POLY FLY 100 WITH SLOPE WITH THIN COVER (AISI 304 STAINLESS STEEL)

CENTRAL SLOT

Grating width 150 mm

Polymer concrete channel with stainless steel edge rails complying with the UNI EN 1433 standard.

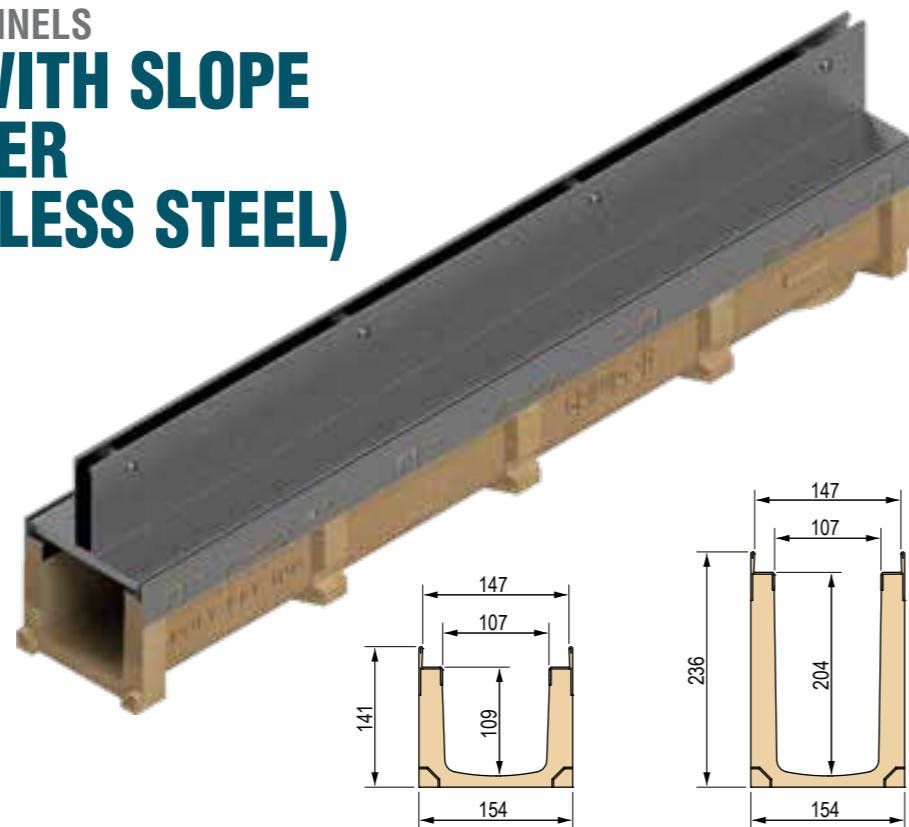

Channel L mm	Code	Description	Slope	Initial H mm	Final H mm	Weight kg
1,000	4G03S01	Channel no. 1	0.5%	141	146	14.14
	4G03S02	Channel no. 2	0.5%	146	151	14.63
	4G03S03	Channel no. 3	0.5%	151	156	15.13
	4G03S04	Channel no. 4	0.5%	156	161	15.63
	4G03S05	Channel no. 5	0.5%	161	166	16.13
	4G03S06	Channel no. 6	0.5%	166	171	16.64
	4G03S07	Channel no. 7	0.5%	171	176	17.14
	4G03S08	Channel no. 8	0.5%	176	181	17.64
	4G03S09	Channel no. 9	0.5%	181	186	18.14
	4G03S10	Channel no. 10	0.5%	186	191	18.64
	4G03S11	Channel no. 11	0.5%	191	196	19.14
	4G03S12	Channel no. 12	0.5%	196	201	19.64
	4G03S13	Channel no. 13	0.5%	201	206	20.15
	4G03S14	Channel no. 14	0.5%	206	211	20.65
	4G03S15	Channel no. 15	0.5%	211	216	21.15
	4G03S16	Channel no. 16	0.5%	216	221	21.65
	4G03S17	Channel no. 17	0.5%	221	226	22.15
	4G03S18	Channel no. 18	0.5%	226	231	22.65
	4G03S19	Channel no. 19	0.5%	231	236	23.15
	4G03S20	Channel no. 20	0.5%	236	241	23.66

Poly Fly 100 with slope AISI 304 stainless steel sump unit without grating

Sump unit L mm	Code	Description	Weight kg
500	4G03PI	AISI 304 stainless steel sump unit L 500 mm	14.23

Available Thin covers

N.B.: available on request with 10 mm heelguard slot and in AISI 316 stainless steel

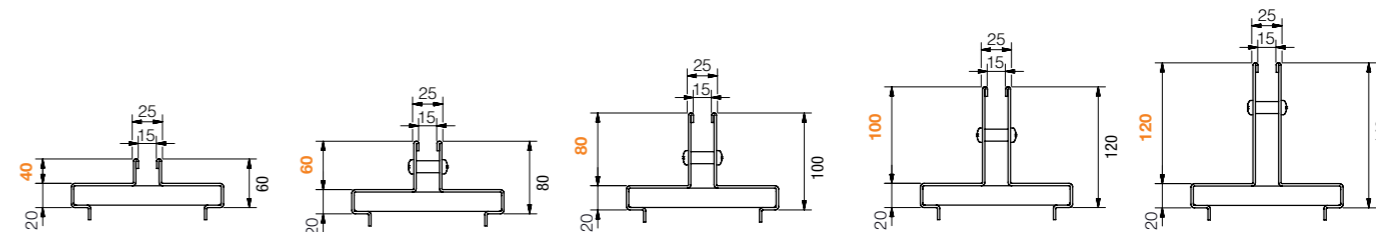

Thin covers with central slot - Slot width 15 mm

AISI 304 STAINLESS STEEL

Cover L mm	Code	Description	Slot height mm	Weight kg	Load class
1,000	4G03I0	Thin central cover made of AISI 304 stainless steel Th. 20/10	40	5.28	C 250
	4G03I1	Thin central cover made of AISI 304 stainless steel Th. 20/10	60	5.91	
	4G03I2	Thin central cover made of AISI 304 stainless steel Th. 20/10	80	6.54	D 400
	4G03I3	Thin central cover made of AISI 304 stainless steel Th. 20/10	100	7.17	
	4G03I4	Thin central cover made of AISI 304 stainless steel Th. 20/10	120	7.29	
500	4G05I0	Thin central cover made of AISI 304 stainless steel Th. 20/10	40	2.63	C 250
	4G05I1	Thin central cover made of AISI 304 stainless steel Th. 20/10	60	2.95	
	4G05I2	Thin central cover made of AISI 304 stainless steel Th. 20/10	80	3.27	D 400
	4G05I3	Thin central cover made of AISI 304 stainless steel Th. 20/10	100	3.58	
	4G05I4	Thin central cover made of AISI 304 stainless steel Th. 20/10	120	3.90	
	4G05I5	Thin central cover made of AISI 304 stainless steel Th. 20/10	140	4.21	

N.B.: the Thin cover is supplied loose



Inspection buckets for Thin covers with central slot - Slot width 15 mm

AISI 304 STAINLESS STEEL

Bucket L mm	Code	Description	Slot height mm	Weight kg	Load class
500	4G03V0	Inspection bucket for Thin central cover made of AISI 304 stainless steel	40	3.97	C 250
	4G03V1	Inspection bucket for Thin central cover made of AISI 304 stainless steel	60	4.72	
	4G03V2	Inspection bucket for Thin central cover made of AISI 304 stainless steel	80	5.46	D 400
	4G03V3	Inspection bucket for Thin central cover made of AISI 304 stainless steel	100	6.20	
	4G03V4	Inspection bucket for Thin central cover made of AISI 304 stainless steel	120	6.94	
	4G03V5	Inspection bucket for Thin central cover made of AISI 304 stainless steel	140	7.68	

N.B.: the Thin bucket is supplied loose

POLYMER CONCRETE CHANNELS POLY FLY 100 WITH SLOPE WITH THIN COVER (AISI 304 STAINLESS STEEL)

SIDE SLOT

Grating width 150 mm

Polymer concrete channel with stainless steel edge rails complying with the UNI EN 1433 standard.

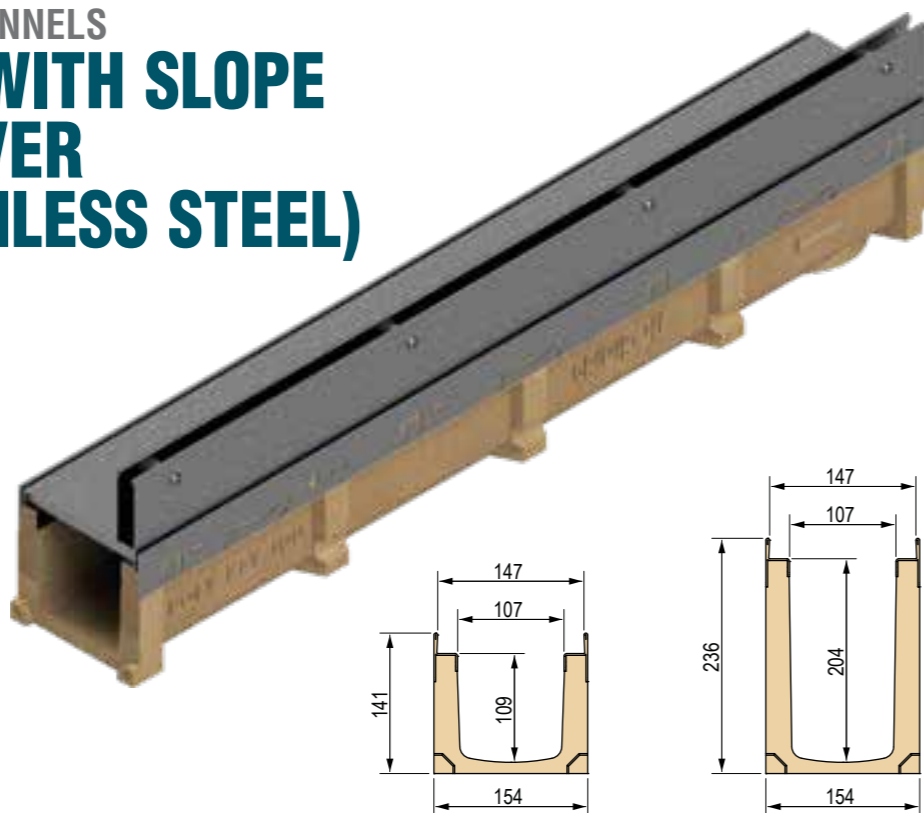

Channel L mm	Code	Description	Slope	Initial H mm	Final H mm	Weight kg
1,000	4G03S01	Channel no. 1	0.5%	141	146	14.14
	4G03S02	Channel no. 2	0.5%	146	151	14.63
	4G03S03	Channel no. 3	0.5%	151	156	15.13
	4G03S04	Channel no. 4	0.5%	156	161	15.63
	4G03S05	Channel no. 5	0.5%	161	166	16.13
	4G03S06	Channel no. 6	0.5%	166	171	16.64
	4G03S07	Channel no. 7	0.5%	171	176	17.14
	4G03S08	Channel no. 8	0.5%	176	181	17.64
	4G03S09	Channel no. 9	0.5%	181	186	18.14
	4G03S10	Channel no. 10	0.5%	186	191	18.64
	4G03S11	Channel no. 11	0.5%	191	196	19.14
	4G03S12	Channel no. 12	0.5%	196	201	19.64
	4G03S13	Channel no. 13	0.5%	201	206	20.15
	4G03S14	Channel no. 14	0.5%	206	211	20.65
	4G03S15	Channel no. 15	0.5%	211	216	21.15
	4G03S16	Channel no. 16	0.5%	216	221	21.65
	4G03S17	Channel no. 17	0.5%	221	226	22.15
	4G03S18	Channel no. 18	0.5%	226	231	22.65
	4G03S19	Channel no. 19	0.5%	231	236	23.15
	4G03S20	Channel no. 20	0.5%	236	241	23.66

Poly Fly 100 with slope AISI 304 stainless steel sump unit without grating

Sump unit L mm	Code	Description	Weight kg
500	4G03PI	AISI 304 stainless steel sump unit L 500 mm	14.23

Available Thin covers

N.B.: available on request with 10 mm heelguard slot and in AISI 316 stainless steel

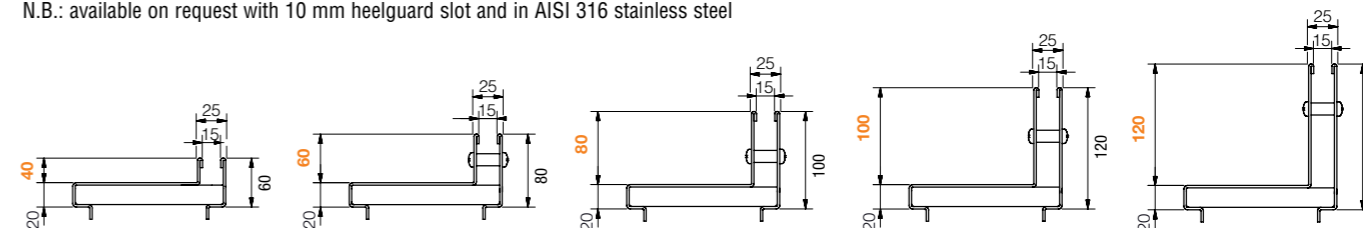

Thin covers with side slot - Slot width 15 mm

AISI 304 STAINLESS STEEL

Cover L mm	Code	Description	Slot height mm	Weight kg	Load class
1,000	4G03IL0	Thin side cover made of AISI 304 stainless steel Th. 20/10	40	5.28	C 250
	4G03IL	Thin side cover made of AISI 304 stainless steel Th. 20/10	60	5.91	
	4G03IL1	Thin side cover made of AISI 304 stainless steel Th. 20/10	80	6.54	D 400
	4G03IL2	Thin side cover made of AISI 304 stainless steel Th. 20/10	100	7.17	
	4G03IL3	Thin side cover made of AISI 304 stainless steel Th. 20/10	120	7.29	
500	4G05IL0	Thin side cover made of AISI 304 stainless steel Th. 20/10	40	2.63	C 250
	4G05IL	Thin side cover made of AISI 304 stainless steel Th. 20/10	60	2.95	
	4G05IL1	Thin side cover made of AISI 304 stainless steel Th. 20/10	80	3.27	D 400
	4G05IL2	Thin side cover made of AISI 304 stainless steel Th. 20/10	100	3.58	
	4G05IL3	Thin side cover made of AISI 304 stainless steel Th. 20/10	120	3.90	

N.B.: the Thin cover is supplied loose



Inspection buckets for Thin covers with side slot - Slot width 15 mm

AISI 304 STAINLESS STEEL

Bucket L mm	Code	Description	Slot height mm	Weight kg	Load class
500	4G05VL10	Inspection bucket for Thin side cover made of AISI 304 stainless steel	40	3.97	C 250
	4G05VLI	Inspection bucket for Thin side cover made of AISI 304 stainless steel	60	4.72	
	4G05VL11	Inspection bucket for Thin side cover made of AISI 304 stainless steel	80	5.46	D 400
	4G05VL12	Inspection bucket for Thin side cover made of AISI 304 stainless steel	100	6.20	
	4G05VL13	Inspection bucket for Thin side cover made of AISI 304 stainless steel	120	6.94	

N.B.: the Thin bucket is supplied loose

POLYMER CONCRETE CHANNELS

POLY FLY 150 (galvanised edge rail)

Grating width 200 mm

Polymer concrete channel with galvanised edge rails complying with the UNI EN 1433 standard. The channels are sold exclusively in complete pallets and together with the gratings.

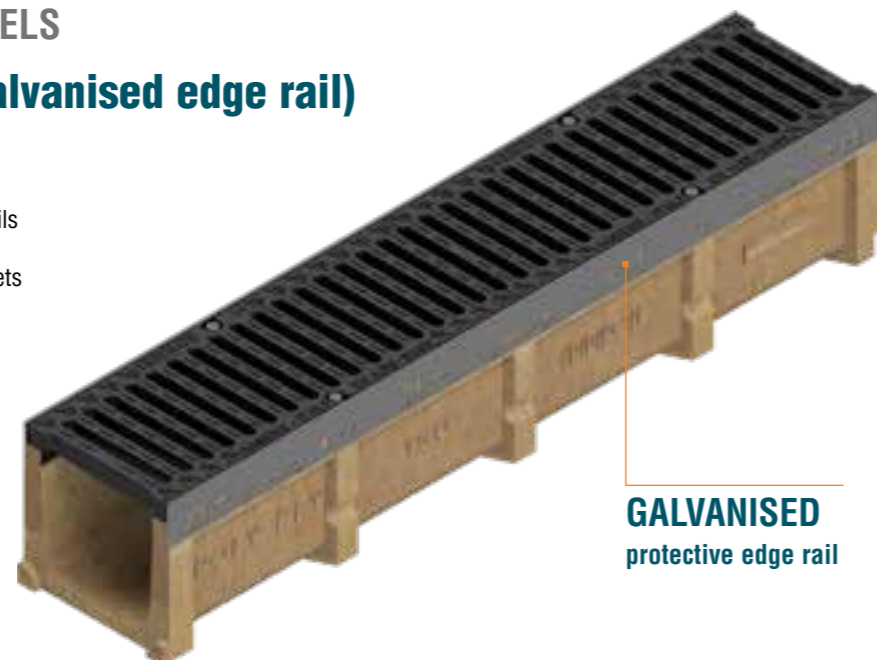

Poly Fly 150 channel dimensions

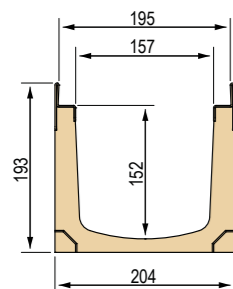

Available gratings



Poly Fly 150 channel (galvanised edge rail) complete with grating - Length 1,000 mm

WITH GALVANISED PROTECTIVE EDGE RAIL

Channel L mm	Code	Grating	Description of the channel assembled with the grating complete with accessories	Weight kg	Load class
1,000	4G12SLC	①	Channel complete with galvanised press-formed metal sheet grating 12/10 with C-shaped edges	22.78	A 15
	4G12SG1	②	Channel complete with pressure-locked grating with C-shaped edges, 25x2-10x2 33x33, hot-dip galvanised	24.33	C 250
	4G12SG2	③	Channel complete with pressure-locked grating with C-shaped edges, 25x2-10x2 55x11 heelguard mesh, hot-dip galvanised	24.96	
	4G12SG3	④	Channel complete with pressure-locked grating with C-shaped edges, 25x2-10x2 33x11 heelguard mesh, hot-dip galvanised	25.92	
	4G12SGS	⑤	Channel complete with 2 x GJS500-7 ductile iron gratings	37.56	D 400
	4G12SGSA	⑥	Channel complete with 2 x GJS500-7 ductile iron heelguard gratings	37.54	
	4G12SP	⑦	Channel complete with embossed metal sheet solid plate Th. 3, reinforced and hot-dip galvanised	37.17	

Poly Fly 150 channel (galvanised edge rail) accessories

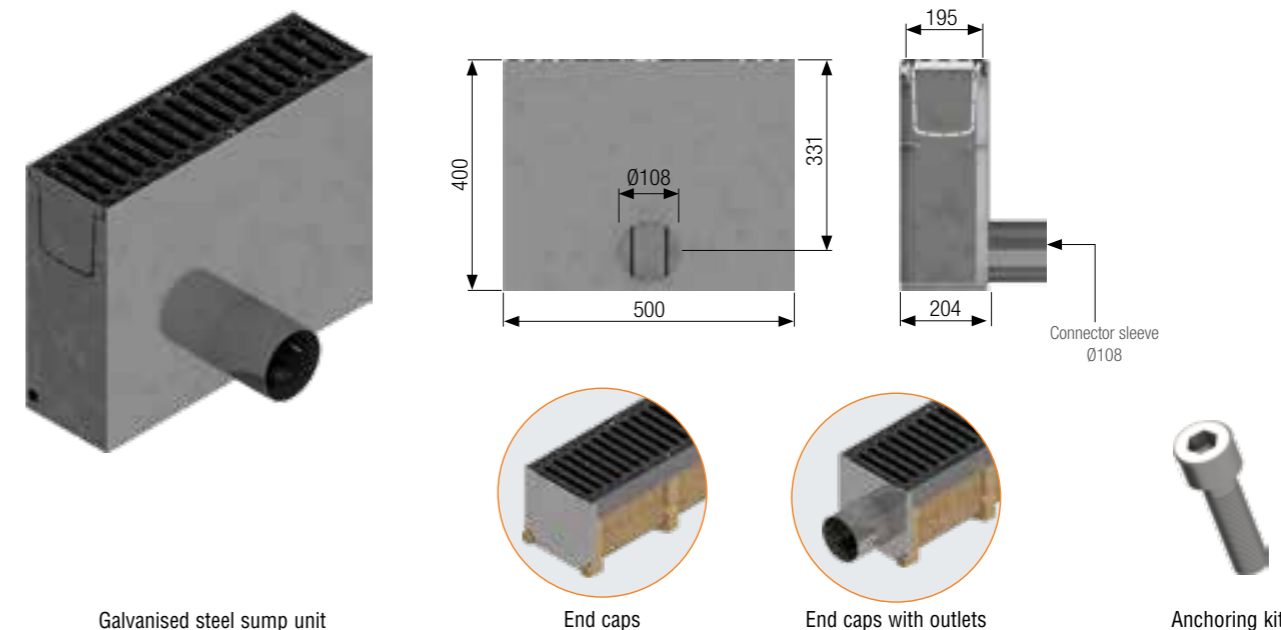

Poly Fly 150 galvanised steel sump unit complete with grating - Length 500 mm

Sump unit L mm	Code	Grating	Description of the sump unit assembled with the grating complete with accessories	Weight kg	Load class
500	4G12PZLC	①	Sump unit complete with galvanised press-formed metal sheet grating 12/10 with C-shaped edges	41.22	A 15
	4G12PZG1	②	Sump unit complete with pressure-locked grating with C-shaped edges, 25x2-10x2 33x33, hot-dip galvanised	41.19	C 250
	4G12PZG2	③	Sump unit complete with pressure-locked grating with C-shaped edges, 25x2-10x2 55x11 heelguard mesh, hot-dip galvanised	41.97	
	4G12PZG3	④	Sump unit complete with pressure-locked grating with C-shaped edges, 25x2-10x2 33x11 heelguard mesh, hot-dip galvanised	42.28	
	4G12PZGS	⑤	Sump unit complete with GJS500-7 ductile iron grating	45.52	D 400
	4G12PZGSA	⑥	Sump unit complete with GJS500-7 ductile iron heelguard grating	47.31	
	4G12PZP	⑦	Sump unit complete with embossed metal sheet solid plate Th. 3, reinforced and hot-dip galvanised	43.50	

Poly Fly 150 galvanised steel sump unit without grating and accessories

Code	Description	Weight kg
4G12PZ	Galvanised steel sump unit L 500 mm	40.12
4G12TI	AISI 304 stainless steel sheet end cap, thickness 15/10	0.53
4G12RI	AISI 304 stainless steel sheet end cap with outlet, thickness 15/10 Ø108 mm	1.30
4D10K	Anchoring kit for galvanised and AISI 304 stainless steel gratings (for gratings 2 - 3 - 4)	0.02
4D10V	Anchoring kit for ductile iron gratings (for gratings 5 - 6)	0.02
4D10P	Anchoring kit for galvanised/AISI 304 stainless steel plates (for plate 7)	0.02

Poly Fly 150 channel (galvanised edge rail) without grating - Length 1,000 mm

Channel L mm	Code	Description	Water passage mm	Run-off section cm ²	Weight kg	Pieces pallet
1,000	4G12S	Poly Fly 150 polymer concrete channel with galvanised protective edge rail	157	220	21.66	35

POLYMER CONCRETE CHANNELS

POLY FLY 150 (AISI 304 stainless steel edge rail)

Grating width 200 mm

Polymer concrete channel with stainless steel edge rails complying with the UNI EN 1433 standard. The channels are sold exclusively in complete pallets and together with the gratings.



AISI 304 STAINLESS STEEL
protective edge rails

Poly Fly 150 channel dimensions

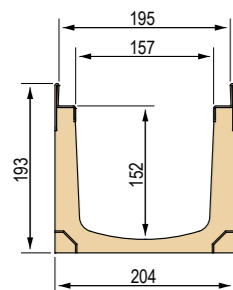

Available gratings

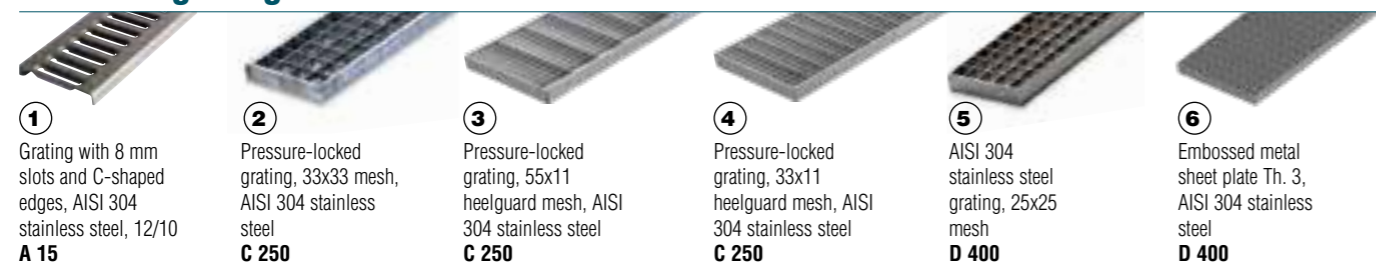

- ① Grating with 8 mm slots and C-shaped edges, AISI 304 stainless steel, 12/10
A 15
- ② Pressure-locked grating, 33x33 mesh, AISI 304 stainless steel
C 250
- ③ Pressure-locked grating, 55x11 heelguard mesh, AISI 304 stainless steel
C 250
- ④ Pressure-locked grating, 33x11 heelguard mesh, AISI 304 stainless steel
C 250
- ⑤ AISI 304 stainless steel grating, 25x25 mesh
D 400
- ⑥ Embossed metal sheet plate Th. 3, AISI 304 stainless steel
D 400

Poly Fly 150 channel (AISI 304 stainless steel edge rail) complete with grating - Length 1,000 mm

WITH AISI 304 STAINLESS STEEL PROTECTIVE EDGE RAIL

Channel L mm	Code	Grating	Description of the channel assembled with the grating complete with accessories	Weight kg	Load class
1,000	4G13SLCI	①	Channel complete with AISI 304 stainless steel press-formed metal sheet grating 12/10 with C-shaped edges	22.78	A 15
	4G13SX1	②	Channel complete with pressure-locked grating with edging, 25x2-10x2 33x33, AISI 304 stainless steel	24.33	C 250
	4G13SX2	③	Channel complete with pressure-locked grating with edging, 25x2-10x2 55x11 heelguard mesh, AISI 304 stainless steel	24.96	
	4G13SX3	④	Channel complete with pressure-locked grating with edging, 25x2-10x2 33x11 heelguard mesh, AISI 304 stainless steel	25.92	
	4G13SX4	⑤	Channel complete with pressure-locked grating with edging, 25x3-10x2 25x25, AISI 304 stainless steel	28.35	D 400
	4G13SPI	⑥	Channel complete with embossed metal sheet solid plate Th. 3, AISI 304 stainless steel, reinforced	37.17	

Poly Fly 150 channel (AISI 304 edge rail) accessories

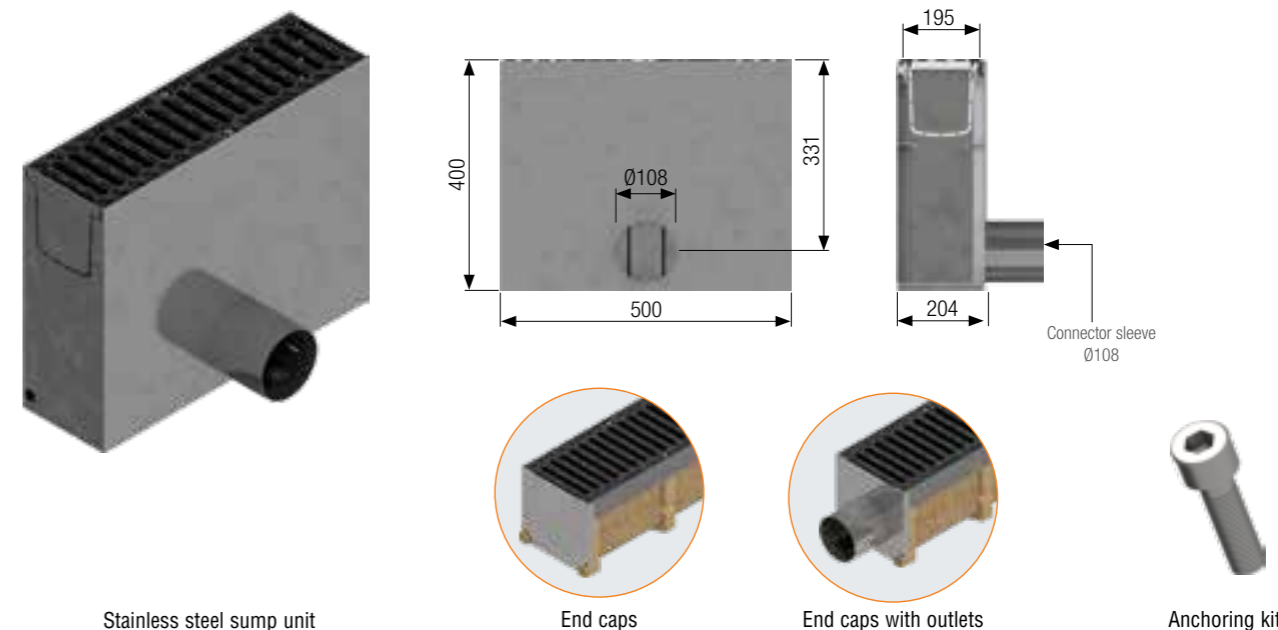

Stainless steel sump unit

End caps

End caps with outlets

Anchoring kit

Poly Fly 150 AISI 304 stainless steel sump unit complete with grating - Length 500 mm

Sump unit L mm	Code	Grating	Description of the sump unit assembled with the grating complete with accessories	Weight kg	Load class
500	4G13PILCI	①	Sump unit complete with AISI 304 stainless steel press-formed metal sheet grating 12/10 with C-shaped edges	41.19	A 15
	4G13PIX1	②	Sump unit complete with pressure-locked grating with edging, 25x2-10x2 33x33, AISI 304 stainless steel	41.97	C 250
	4G13PIX2	③	Sump unit complete with pressure-locked grating with edging, 25x2-10x2 55x11, heelguard mesh, AISI 304 stainless steel	42.28	
	4G13PIX3	④	Sump unit complete with pressure-locked grating with edging, 25x2-10x2 33x11, heelguard mesh, AISI 304 stainless steel	42.76	
	4G13PIX4	⑤	Sump unit complete with pressure-locked grating with edging, 25x3-10x2 25x25, AISI 304 stainless steel	43.98	D 400
	4G13PIPI	⑥	Sump unit complete with embossed metal sheet solid plate Th. 3, AISI 304 stainless steel, reinforced	48.39	

Poly Fly 150 AISI 304 stainless steel sump unit without grating and accessories

Code	Description	Weight kg
4G13PI	AISI 304 stainless steel sump unit L 500 mm	40.12
4G12TI	AISI 304 stainless steel sheet end cap, thickness 15/10	0.53
4G12RI	AISI 304 stainless steel sheet end cap with outlet, thickness 15/10 Ø108 mm	1.30
4D10K	Anchoring kit for galvanised and AISI 304 stainless steel gratings (for gratings 2 - 5)	0.02
4D10A	Anchoring kit for AISI 304 stainless steel heelguard gratings (for gratings 3 - 4)	0.02
4D10P	Anchoring kit for AISI 304 stainless steel plates (for plate 6)	0.02

Poly Fly 150 channel (AISI 304 stainless steel edge rail) without grating - Length 1,000 mm

Channel L mm	Code	Description	Water passage mm	Run-off section cm ²	Weight kg	Pieces pallet
1,000	4G13S	Poly Fly 150 polymer concrete channel with AISI 304 stainless steel protective edge rail	157	220	22.06	35

POLYMER CONCRETE CHANNELS

POLY FLY 150 Low

(galvanised edge rail)
Grating width 200 mm

Polymer concrete channel with galvanised edge rails complying with the UNI EN 1433 standard. The channels are sold exclusively in complete pallets and together with the gratings.



Poly Fly 150 Low channel dimensions

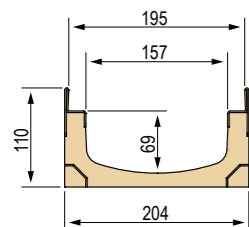

Available gratings



Poly Fly 150 Low channel (galvanised edge rail) complete with grating - Length 1,000 mm

WITH GALVANISED PROTECTIVE EDGE RAIL

Channel L mm	Code	Grating	Description of the channel assembled with the grating complete with accessories	Weight kg	Load class
1,000	4G1CSLC	①	Channel complete with galvanised press-formed metal sheet grating 12/10 with C-shaped edges	17.58	A 15
	4G1CSG1	②	Channel complete with pressure-locked grating with C-shaped edges, 25x2-10x2 33x33, hot-dip galvanised	19.13	
	4G1CSG2	③	Channel complete with pressure-locked grating with C-shaped edges, 25x2-10x2 55x11 heelguard mesh, hot-dip galvanised	19.76	C 250
	4G1CSG3	④	Channel complete with pressure-locked grating with C-shaped edges, 25x2-10x2 33x11 heelguard mesh, hot-dip galvanised	20.72	
	4G1CSGS	⑤	Channel complete with 2 x GJS500-7 ductile iron gratings	29.82	D 400
	4G1CSGSA	⑥	Channel complete with 2 x GJS500-7 ductile iron heelguard gratings	29.20	
	4G1CSP	⑦	Channel complete with embossed metal sheet solid plate Th. 3, reinforced and hot-dip galvanised	31.97	

Poly Fly 150 Low channel (galvanised edge rail) accessories

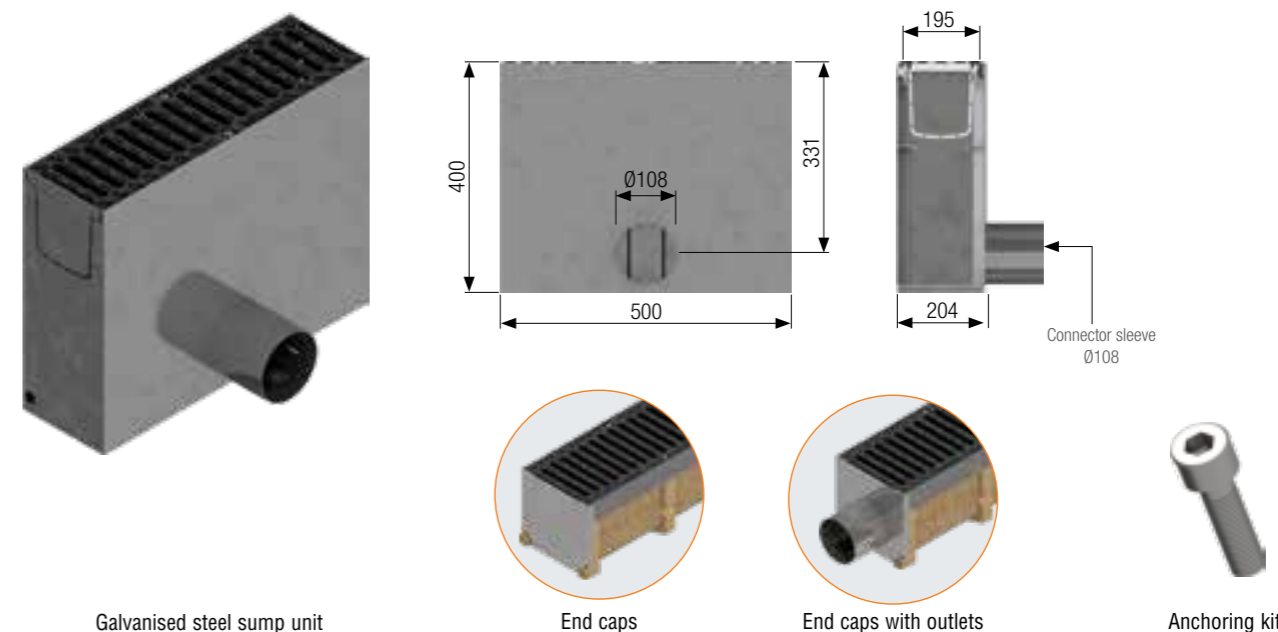

Poly Fly 150 Low galvanised steel sump unit complete with grating - Length 500 mm

Sump unit L mm	Code	Grating	Description of the sump unit assembled with the grating complete with accessories	Weight kg	Load class
500	4G12PZLC	①	Sump unit complete with galvanised press-formed metal sheet grating 12/10 with C-shaped edges	41.22	A 15
	4G12PZG1	②	Sump unit complete with pressure-locked grating with C-shaped edges, 25x2-10x2 33x33, hot-dip galvanised	41.19	
	4G12PZG2	③	Sump unit complete with pressure-locked grating with C-shaped edges, 25x2-10x2 55x11 heelguard mesh, hot-dip galvanised	41.97	C 250
	4G12PZG3	④	Sump unit complete with pressure-locked grating with C-shaped edges, 25x2-10x2 33x11 heelguard mesh, hot-dip galvanised	42.28	
	4G12PZGS	⑤	Sump unit complete with GJS500-7 ductile iron grating	45.52	D 400
	4G12PZGSA	⑥	Sump unit complete with GJS500-7 ductile iron heelguard grating	47.31	
	4G12PZP	⑦	Sump unit complete with embossed metal sheet solid plate Th. 3, reinforced and hot-dip galvanised	43.50	

Poly Fly 150 Low galvanised steel sump unit without grating and accessories

Code	Description	Weight kg
4G12PZ	Galvanised steel sump unit L 500 mm	40.12
4G1DTI	AISI 304 stainless steel sheet end cap, thickness 15/10	0.48
4G1DRI	AISI 304 stainless steel sheet end cap with outlet, thickness 15/10 Ø76 mm	1.15
4D10K	Anchoring kit for galvanised and AISI 304 stainless steel gratings (for gratings 2 - 3 - 4)	0.02
4D10V	Anchoring kit for ductile iron gratings (for gratings 5 - 6)	0.02
4D10P	Anchoring kit for galvanised/AISI 304 stainless steel plates (for plate 7)	0.02

Poly Fly 150 Low channel (galvanised edge rail) without grating - Length 1,000 mm

Channel L mm	Code	Description	Water passage mm	Run-off section cm ²	Weight kg	Pieces pallet
1,000	4G1CS	Poly Fly 150 Low polymer concrete channel with galvanised protective edge rail	157	93	15.20	55

POLYMER CONCRETE CHANNELS

POLY FLY 150 Low

(AISI 304 stainless steel edge rail)

Grating width 200 mm

Polymer concrete channel with stainless steel edge rails complying with the UNI EN 1433 standard. The channels are sold exclusively in complete pallets and together with the gratings.



Poly Fly 150 Low channel dimensions

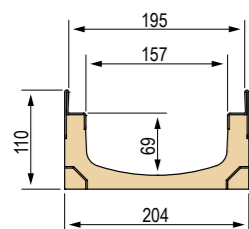

Available gratings

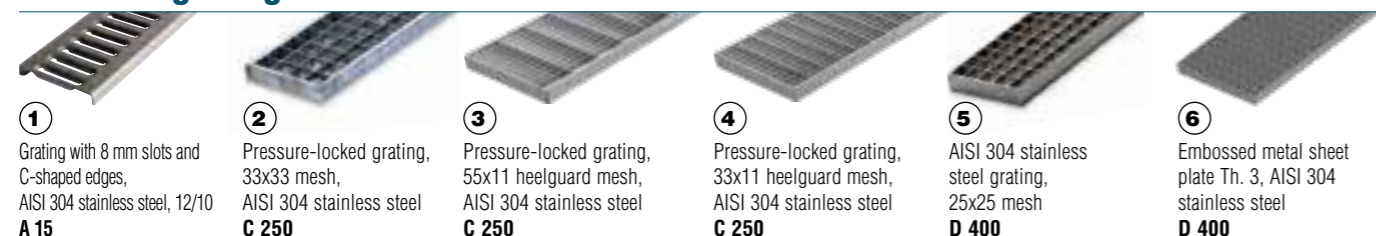

Poly Fly 150 Low channel (AISI 304 stainless steel edge rail) complete with grating - Length 1,000 mm

WITH AISI 304 STAINLESS STEEL PROTECTIVE EDGE RAIL

Channel L mm	Code	Grating	Description of the channel assembled with the grating complete with accessories	Weight kg	Load class
1,000	4G1DSLCL	①	Channel complete with AISI 304 stainless steel press-formed metal sheet grating 12/10 with C-shaped edges	17.58	A 15
	4G1DSX1	②	Channel complete with pressure-locked grating with edging, 25x2-10x2 33x33, AISI 304 stainless steel	19.13	C 250
	4G1DSX2	③	Channel complete with pressure-locked grating with edging, 25x2-10x2 55x11 heelguard mesh, AISI 304 stainless steel	19.76	
	4G1DSX3	④	Channel complete with pressure-locked grating with edging, 25x2-10x2 33x11 heelguard mesh, AISI 304 stainless steel	20.72	
	4G1DSX4	⑤	Channel complete with pressure-locked grating with edging, 25x3-10x2 25x25, AISI 304 stainless steel	23.15	D 400
	4G1DSP1	⑥	Channel complete with embossed metal sheet solid plate Th. 3, AISI 304 stainless steel, reinforced	31.97	

Poly Fly 150 Low channel (AISI 304 edge rail) accessories

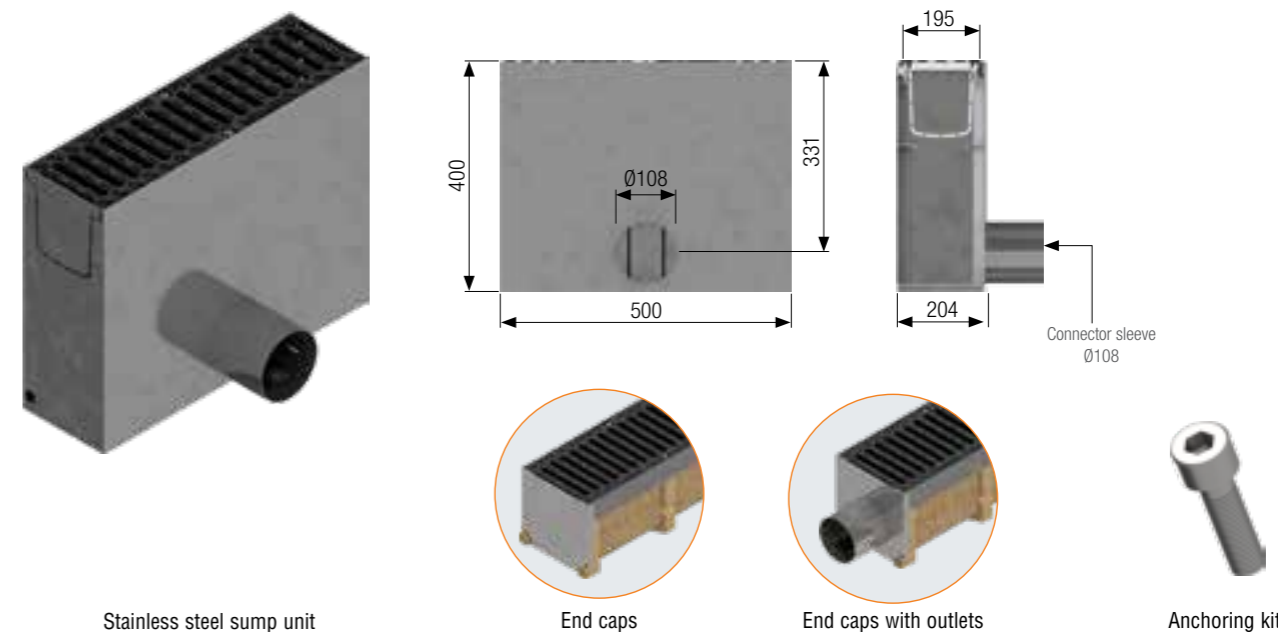

Poly Fly 150 Low AISI 304 stainless steel sump unit complete with grating - Length 500 mm

Sump unit L mm	Code	Grating	Description of the sump unit assembled with the grating complete with accessories	Weight kg	Load class
500	4G13PILCI	①	Sump unit complete with AISI 304 stainless steel press-formed metal sheet grating 12/10 with C-shaped edges	41.19	A 15
	4G13PIX1	②	Sump unit complete with pressure-locked grating with edging, 25x2-10x2 33x33, AISI 304 stainless steel	41.97	C 250
	4G13PIX2	③	Sump unit complete with pressure-locked grating with edging, 25x2-10x2 55x11, heelguard mesh, AISI 304 stainless steel	42.28	
	4G13PIX3	④	Sump unit complete with pressure-locked grating with edging, 25x2-10x2 33x11, heelguard mesh, AISI 304 stainless steel	42.76	
	4G13PIX4	⑤	Sump unit complete with pressure-locked grating with edging, 25x3-10x2 25x25, AISI 304 stainless steel	43.98	D 400
	4G13PIPI	⑥	Sump unit complete with embossed metal sheet solid plate Th. 3, AISI 304 stainless steel, reinforced	48.39	

Poly Fly 150 Low AISI 304 stainless steel sump unit without grating and accessories

Code	Description	Weight kg
4G13PI	AISI 304 stainless steel sump unit L 500 mm	40.12
4G1DTI	AISI 304 stainless steel sheet end cap, thickness 15/10	0.48
4G1DRI	AISI 304 stainless steel sheet end cap with outlet, thickness 15/10 Ø76 mm	1.15
4D10K	Anchoring kit for galvanised and AISI 304 stainless steel gratings (for gratings 2 - 5)	0.02
4D10A	Anchoring kit for AISI 304 stainless steel heelguard gratings (for gratings 3 - 4)	0.02
4D10P	Anchoring kit for AISI 304 stainless steel plates (for plate 6)	0.02

Poly Fly 150 Low channel (AISI 304 stainless steel edge rail) without grating - Length 1,000 mm

Channel L mm	Code	Description	Water passage mm	Run-off section cm ²	Weight kg	Pieces pallet
1,000	4G1DS	Poly Fly 150 Low polymer concrete channel with AISI 304 stainless steel edge rail	157	93	15.83	55

POLYMER CONCRETE CHANNELS

POLY FLY 150 WITH SLOPE

(galvanised edge rail)

Grating width 200 mm

Polymer concrete channel with galvanised edge rails complying with the UNI EN 1433 standard.

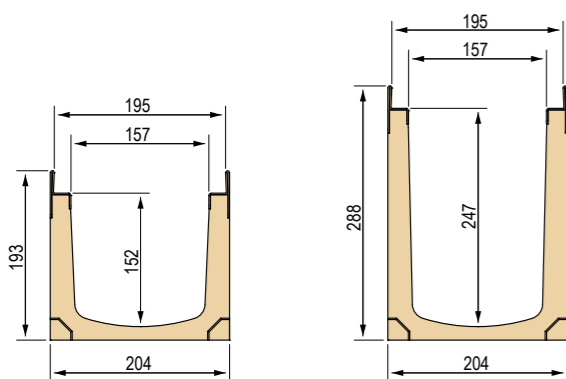

Channel L mm	Code	Description	Slope	Initial H mm	Final H mm	Weight kg
1000	4G12S01	Channel no. 1	0,5%	193	198	21,66
	4G12S02	Channel no. 2	0,5%	198	203	22,15
	4G12S03	Channel no. 3	0,5%	203	208	24,32
	4G12S04	Channel no. 4	0,5%	208	213	24,70
	4G12S05	Channel no. 5	0,5%	213	218	25,92
	4G12S06	Channel no. 6	0,5%	218	223	27,05
	4G12S07	Channel no. 7	0,5%	223	228	27,81
	4G12S08	Channel no. 8	0,5%	228	233	28,75
	4G12S09	Channel no. 9	0,5%	233	238	29,78
	4G12S10	Channel no. 10	0,5%	238	243	30,82
	4G12S11	Channel no. 11	0,5%	243	248	31,76
	4G12S12	Channel no. 12	0,5%	248	253	32,71
	4G12S13	Channel no. 13	0,5%	253	258	34,03
	4G12S14	Channel no. 14	0,5%	258	263	34,78
	4G12S15	Channel no. 15	0,5%	263	268	35,72
	4G12S16	Channel no. 16	0,5%	268	273	36,48
	4G12S17	Channel no. 17	0,5%	273	278	37,70
	4G12S18	Channel no. 18	0,5%	278	283	39,21
	4G12S19	Channel no. 19	0,5%	283	288	39,85
	4G12S20	Channel no. 20	0,5%	288	293	40,61

Available gratings

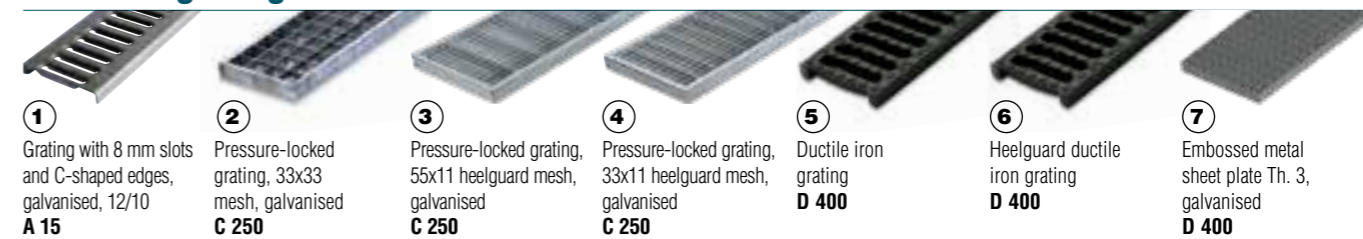

Grating L mm	Code	Grating	Description of gratings complete with accessories	Weight kg	Load class
1000	4D12LC	①	Galvanised press-formed metal sheet grating 12/10 with C-shaped edges	2,38	A 15
	4D12G1	②	Pressure-locked grating with C-shaped edges, 20x2-10x2 33x33, hot-dip galvanised	3,93	C 250
	4D12G2	③	Pressure-locked grating with C-shaped edges, 25x2-10x2 55x11, hot-dip galvanised	4,56	
	4D12G3	④	Pressure-locked grating with C-shaped edges, 25x2-10x2 33x11, hot-dip galvanised	5,52	
500	4D12GS	⑤	GJS500-7 ductile iron gratings	7,37	D 400
	4D12GSA	⑥	GJS500-7 ductile iron heelguard gratings	7,09	
1000	4D12P	⑦	Embossed metal sheet solid plate Th. 3, reinforced and hot-dip galvanised	16,77	

Accessories for Poly Fly 150 with slope channel

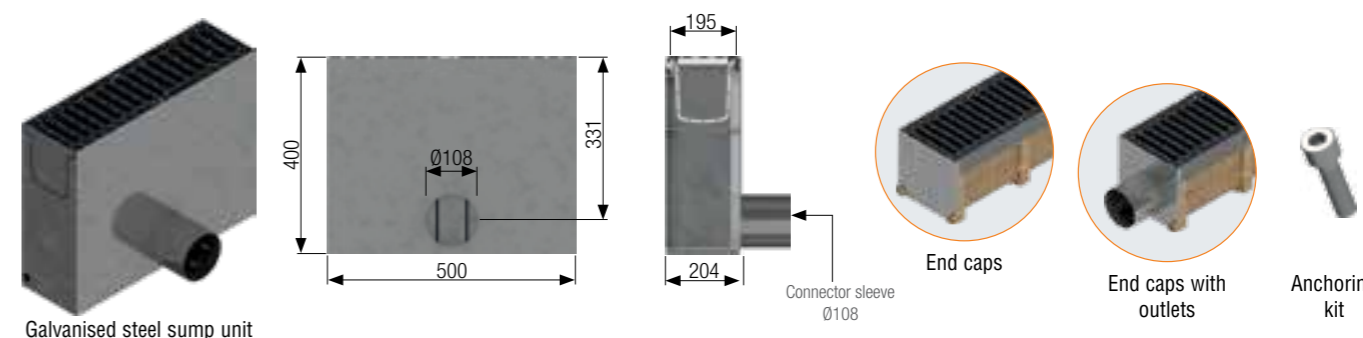

Poly Fly 150 with slope galvanised steel sump unit complete with grating - Length 500 mm

Sump unit L mm	Code	Grating	Description of the sump unit assembled with the grating complete with accessories	Weight kg	Load class
500	4G12PZLC	①	Sump unit complete with galvanised press-formed metal sheet grating 12/10 with C-shaped edges	41,22	A 15
	4G12PZG1	②	Sump unit complete with pressure-locked grating with C-shaped edges, 25x2-10x2 33x33, hot-dip galvanised	41,19	C 250
	4G12PZG2	③	Sump unit complete with pressure-locked grating with C-shaped edges, 25x2-10x2 55x11, heelguard mesh, hot-dip galvanised	41,97	
	4G12PZG3	④	Sump unit complete with pressure-locked grating with C-shaped edges, 25x2-10x2 33x11, heelguard mesh, hot-dip galvanised	42,28	
	4G12PZGS	⑤	Sump unit complete with GJS500-7 ductile iron grating	45,52	D 400
	4G12PZGSA	⑥	Sump unit complete with GJS500-7 ductile iron heelguard grating	47,31	
	4G12PZP	⑦	Sump unit complete with embossed metal sheet solid plate Th. 3, reinforced and hot-dip galvanised	43,5	

Poly Fly 150 with slope galvanised steel sump unit without grating and accessories

Code	Description	Weight kg
4G12PZ	Galvanised steel sump unit L 500 mm	40,12
4G12TI	AISI 304 stainless steel sheet end cap, thickness 15/10	0,53
4G12RI	AISI 304 stainless steel sheet end cap with outlet, thickness 15/10 Ø108 mm	1,3
4D10K	Anchoring kit for galvanised and AISI 304 stainless steel gratings (for gratings 2 - 3 - 4)	0,02
4D10V	Anchoring kit for ductile iron gratings (for gratings 5 - 6)	0,02
4D10P	Anchoring kit for galvanised/AISI 304 stainless steel plates (for plate 7)	0,02

POLYMER CONCRETE CHANNELS

POLY FLY 150 WITH SLOPE

(AISI 304 stainless steel edge rail)

Grating width 200 mm

Polymer concrete channel with stainless steel edge rails complying with the UNI EN 1433 standard.

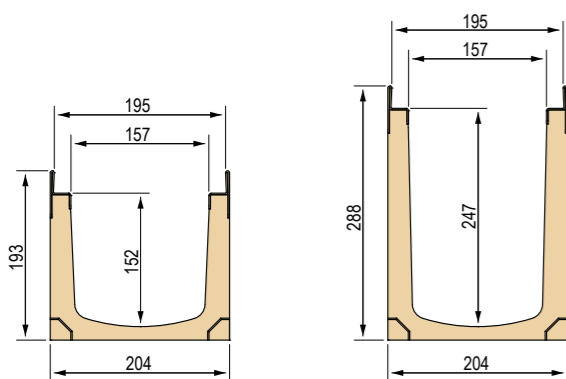

Channel L mm	Code	Description	Slope	Initial H mm	Final H mm	Weight kg
1000	4G13S01	Channel no. 1	0,5%	193	198	21,66
	4G13S02	Channel no. 2	0,5%	198	203	22,15
	4G13S03	Channel no. 3	0,5%	203	208	24,32
	4G13S04	Channel no. 4	0,5%	208	213	24,70
	4G13S05	Channel no. 5	0,5%	213	218	25,92
	4G13S06	Channel no. 6	0,5%	218	223	27,05
	4G13S07	Channel no. 7	0,5%	223	228	27,81
	4G13S08	Channel no. 8	0,5%	228	233	28,75
	4G13S09	Channel no. 9	0,5%	233	238	29,78
	4G13S10	Channel no. 10	0,5%	238	243	30,82
	4G13S11	Channel no. 11	0,5%	243	248	31,76
	4G13S12	Channel no. 12	0,5%	248	253	32,71
	4G13S13	Channel no. 13	0,5%	253	258	34,03
	4G13S14	Channel no. 14	0,5%	258	263	34,78
	4G13S15	Channel no. 15	0,5%	263	268	35,72
	4G13S16	Channel no. 16	0,5%	268	273	36,48
	4G13S17	Channel no. 17	0,5%	273	278	37,70
	4G13S18	Channel no. 18	0,5%	278	283	39,21
	4G13S19	Channel no. 19	0,5%	283	288	39,85
	4G13S20	Channel no. 20	0,5%	288	293	40,61

Available gratings

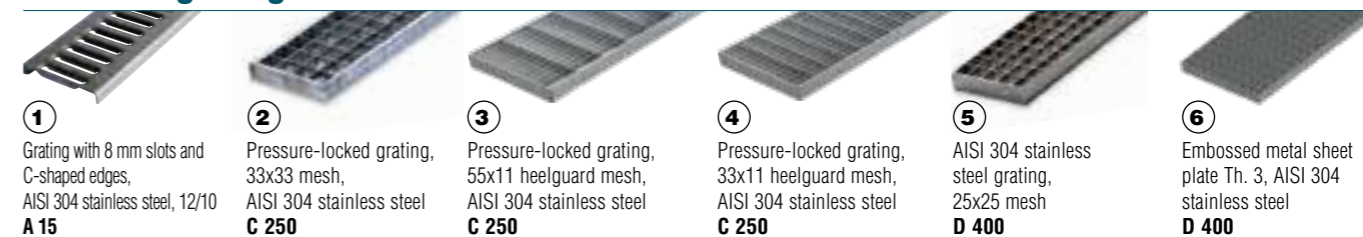

Grating L mm	Code	Grating	Description of gratings complete with accessories	Weight kg	Load class
1000	4D13LCI	①	AISI 304 stainless steel press-formed metal sheet grating 12/10 with C-shaped edges	2,30	A 15
	4D13X1	②	Pressure-locked grating with C-shaped edges, 25x2-10x2 33x33, AISI 304 stainless steel	4,20	C 250
	4D13X2	③	Pressure-locked grating with C-shaped edges, 25x2-10x2 55x11, AISI 304 stainless steel	4,80	
	4D13X3	④	Pressure-locked grating with C-shaped edges, 25x2-10x2 33x11, AISI 304 stainless steel	5,70	
	4D13X4	⑤	Pressure-locked grating with C-shaped edges, 25x3-10x2 25x25, AISI 304 stainless steel	6,60	D 400
	4D11PI	⑥	Embossed metal sheet solid plate Th. 3, AISI 304 stainless steel, reinforced	16,77	

Accessories for Poly Fly 150 with slope channel

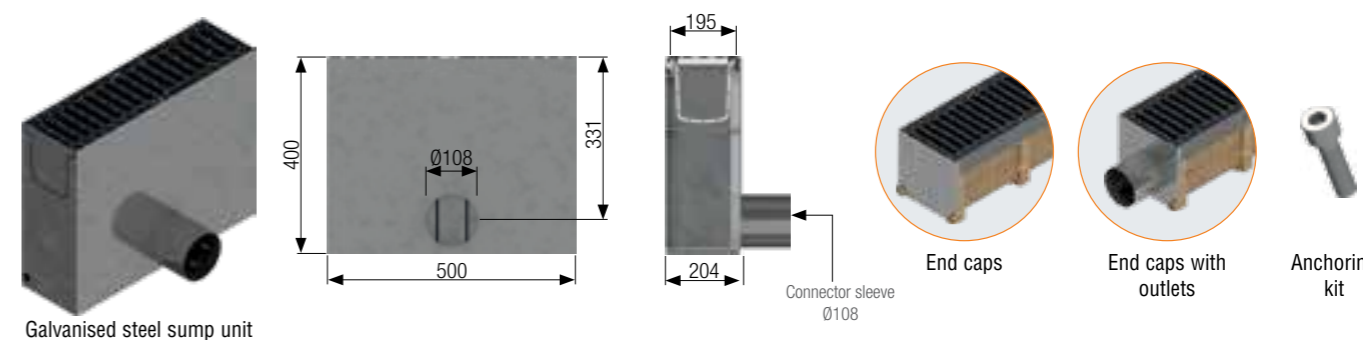

Poly Fly 150 with slope AISI 304 stainless steel sump unit complete with grating - Length 500 mm

Sump unit L mm	Code	Grating	Description of the sump unit assembled with the grating complete with accessories	Weight kg	Load class
500	4G13PILCI	①	Sump unit complete with AISI 304 stainless steel press-formed metal sheet grating 12/10 with C-shaped edges	41,19	A 15
	4G13PIX1	②	Sump unit complete with pressure-locked grating with edging, 25x2-10x2 33x33, AISI 304 stainless steel	41,97	C 250
	4G13PIX2	③	Sump unit complete with pressure-locked grating with edging, 25x2-10x2 55x11, heelguard mesh, AISI 304 stainless steel	42,28	
	4G13PIX3	④	Sump unit complete with pressure-locked grating with edging, 25x2-10x2 33x11, heelguard mesh, AISI 304 stainless steel	42,76	
	4G13PIX4	⑤	Sump unit complete with pressure-locked grating with edging, 25x3-10x2 25x25, AISI 304 stainless steel	43,98	D 400
	4G13PIPI	⑥	Sump unit complete with embossed metal sheet solid plate Th. 3, AISI 304 stainless steel, reinforced	48,39	

Poly Fly 150 with slope AISI 304 stainless steel sump unit without grating and accessories

Code	Description	Weight kg
4G13PI	AISI 304 stainless steel sump unit L 500 mm	40,12
4G12TI	AISI 304 stainless steel sheet end cap, thickness 15/10	0,53
4G12RI	AISI 304 stainless steel sheet end cap with outlet, thickness 15/10 Ø108 mm	1,3
4D10K	Anchoring kit for galvanised and AISI 304 stainless steel gratings (for gratings 2 - 5)	0,02
4D10A	Anchoring kit for AISI 304 stainless steel heelguard gratings (for gratings 3 - 4)	0,02
4D10P	Anchoring kit for galvanised/AISI 304 stainless steel plates (for plate 6)	0,02

POLYMER CONCRETE CHANNELS

POLY FLY 200

(galvanised edge rail)

Grating width 250 mm

Polymer concrete channel with galvanised edge rails complying with the UNI EN 1433 standard. The channels are sold exclusively in complete pallets and together with the gratings.



Poly Fly 200 channel dimensions

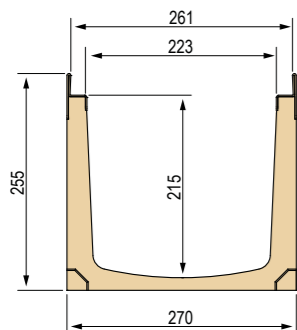

Available gratings

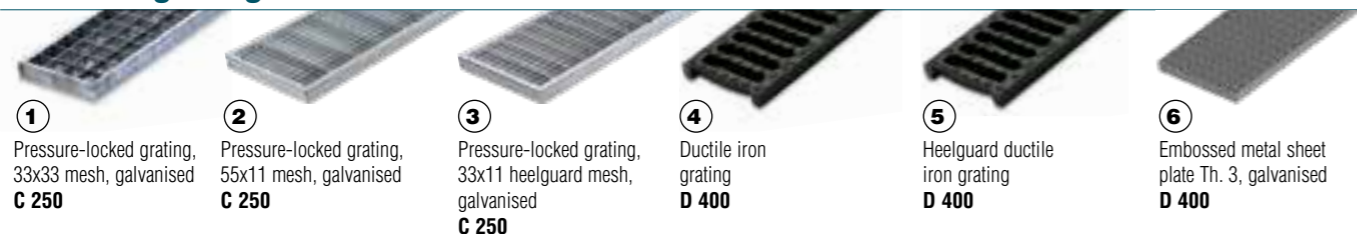

Poly Fly 200 channel (galvanised edge rail) complete with grating - Length 1,000 mm

WITH GALVANISED PROTECTIVE EDGE RAIL

Channel L mm	Code	Grating	Description of the channel assembled with the grating complete with accessories	Weight kg	Load class
1,000	4G22SG1	①	Channel complete with pressure-locked grating with C-shaped edges, 25x2-10x2 33x33, hot-dip galvanised	34.77	C 250
	4G22SG2	②	Channel complete with pressure-locked grating with C-shaped edges, 25x2-10x2 55x11 heelguard mesh, hot-dip galvanised	35.70	
	4G22SG3	③	Channel complete with pressure-locked grating with C-shaped edges, 25x2-10x2 33x11 heelguard mesh, hot-dip galvanised	36.99	
	4G22SGS	④	Channel complete with 2 x GJS500-7 ductile iron gratings	50.13	D 400
	4G22SGSA	⑤	Channel complete with 2 x GJS500-7 ductile iron heelguard gratings	50.91	
	4G22SP	⑥	Channel complete with embossed metal sheet solid plate Th. 3, reinforced and hot-dip galvanised	54.18	

Poly Fly 200 channel (galvanised edge rail) accessories

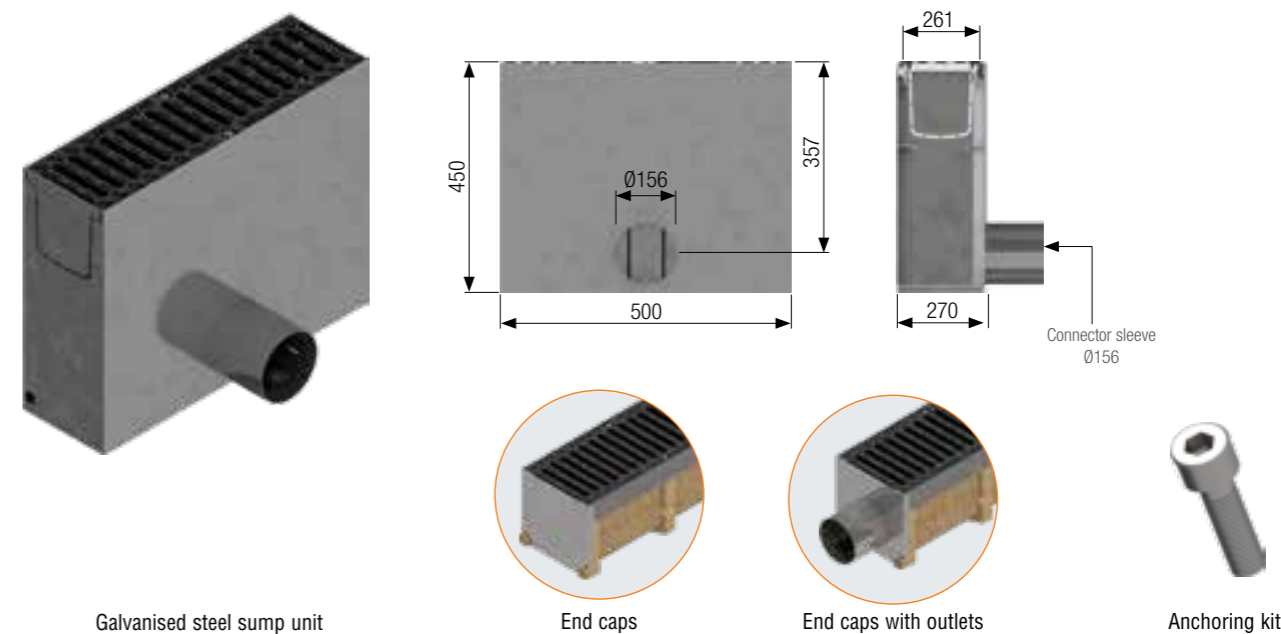

Poly Fly 200 galvanised steel sump unit complete with grating - Length 500 mm

Sump unit L mm	Code	Grating	Description of the sump unit assembled with the grating complete with accessories	Weight kg	Load class
500	4G22PZG1	①	Sump unit complete with pressure-locked grating with C-shaped edges, 25x2-10x2 33x33, hot-dip galvanised	62.55	C 250
	4G22PZG2	②	Sump unit complete with pressure-locked grating with C-shaped edges, 25x2-10x2 55x11 heelguard mesh, hot-dip galvanised	63.02	
	4G22PZG3	③	Sump unit complete with pressure-locked grating with C-shaped edges, 25x2-10x2 33x11, heelguard mesh, hot-dip galvanised	63.66	
	4G22PZGS	④	Sump unit complete with GJS500-7 ductile iron grating	70.23	D 400
	4G22PZGSA	⑤	Sump unit complete with GJS500-7 ductile iron heelguard grating	70.62	
	4G22PZP	⑥	Sump unit complete with embossed metal sheet solid plate Th. 3, reinforced and hot-dip galvanised	72.26	

Poly Fly 200 galvanised steel sump unit without grating and accessories

Code	Description	Weight kg
4G22PZ	Galvanised steel sump unit L 500 mm	61.20
4G22TI	AISI 304 stainless steel sheet end cap, thickness 20/10	1.12
4G22RI	AISI 304 stainless steel sheet end cap with outlet, thickness 20/10, Ø156 mm	1.85
4D10K	Anchoring kit for galvanised and AISI 304 stainless steel gratings (for gratings 1 - 2 - 3)	0.02
4D10V	Anchoring kit for ductile iron gratings (for gratings 4 - 5)	0.02
4D10P	Anchoring kit for galvanised and AISI 304 stainless steel plates (for plate 6)	0.02

Poly Fly 200 channel (galvanised edge rail) without grating - Length 1,000 mm

Channel L mm	Code	Description	Water passage mm	Run-off section cm ²	Weight kg	Pieces pallet
1,000	4G22S	Poly Fly 200 polymer concrete channel with galvanised protective edge rail	223	448	29.67	24

POLYMER CONCRETE CHANNELS

POLY FLY 200

(AISI 304 stainless steel edge rail)

Grating width 250 mm

Polymer concrete channel with stainless steel edge rails complying with the UNI EN 1433 standard. The channels are sold exclusively in complete pallets and together with the gratings.



AISI 304 STAINLESS STEEL
protective edge rails

Poly Fly 200 channel dimensions

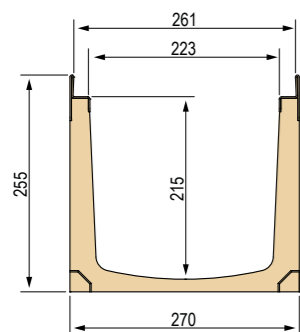

Available gratings



Poly Fly 200 channel (AISI 304 stainless steel edge rail) complete with grating - Length 1,000 mm

WITH AISI 304 STAINLESS STEEL PROTECTIVE EDGE RAIL

Channel L mm	Code	Grating	Description of the channel assembled with the grating complete with accessories	Weight kg	Load class
1,000	4G23SX1	①	Channel complete with pressure-locked grating with edging, 25x2-10x2 33x33, AISI 304 stainless steel	34.97	C 250
	4G23SX2	②	Channel complete with pressure-locked grating with edging, 25x2-10x2 55x11 heelguard mesh, AISI 304 stainless steel	35.77	
	4G23SX3	③	Channel complete with pressure-locked grating with edging, 25x2-10x2 33x11 heelguard mesh, AISI 304 stainless steel	36.97	
	4G23SX4	④	Channel complete with pressure-locked grating with edging, 25x3-10x2 25x25, AISI 304 stainless steel	38.17	D 400
	4G23SPI	⑤	Channel complete with embossed metal sheet solid plate Th. 3, AISI 304 stainless steel, reinforced	54.18	

Poly Fly 200 channel (AISI 304 edge rail) accessories

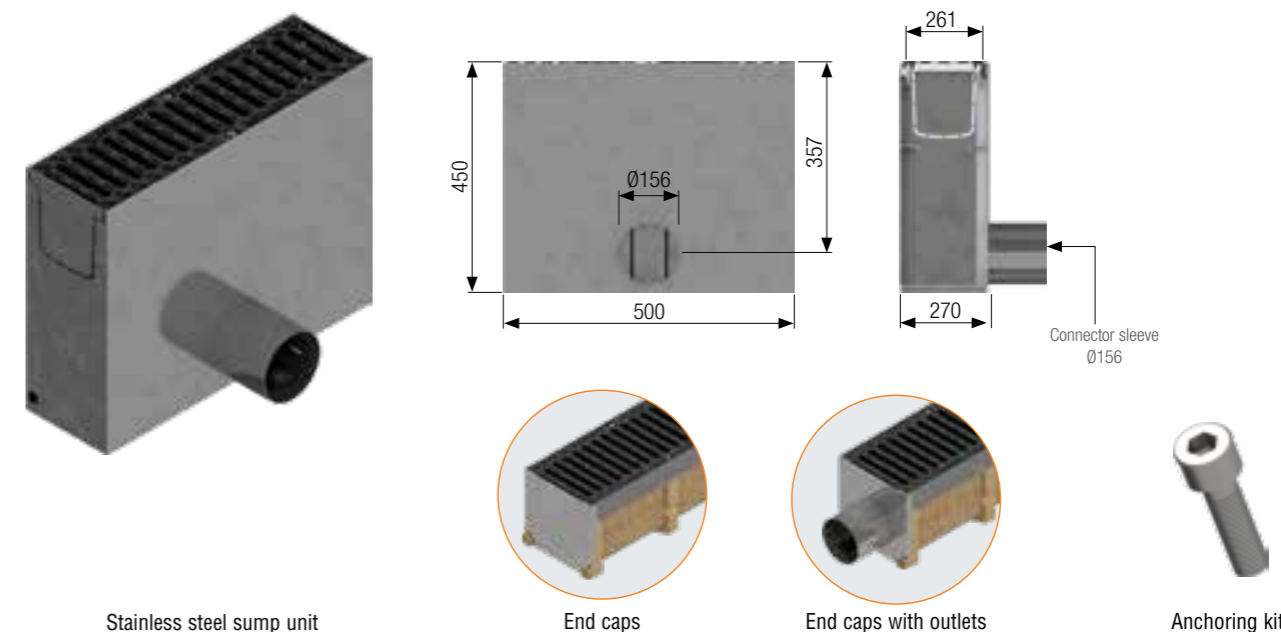

Stainless steel sump unit

End caps

End caps with outlets

Anchoring kit

Poly Fly 200 AISI 304 stainless steel sump unit complete with grating - Length 500 mm

Sump unit L mm	Code	Grating	Description of the sump unit assembled with the grating complete with accessories	Weight kg	Load class
500	4G23PIX1	①	Sump unit complete with pressure-locked grating with edging, 25x2-10x2 33x33, AISI 304 stainless steel	62.65	C 250
	4G23PIX2	②	Sump unit complete with pressure-locked grating with edging, 25x2-10x2 55x11, heelguard mesh, AISI 304 stainless steel	63.05	
	4G23PIX3	③	Sump unit complete with pressure-locked grating with edging, 25x2-10x2 33x11, heelguard mesh, AISI 304 stainless steel	63.65	
	4G23PIX4	④	Sump unit complete with pressure-locked grating with edging, 25x3-10x2 25x25, AISI 304 stainless steel	64.25	D 400
	4G23PIPI	⑤	Sump unit complete with embossed metal sheet solid plate Th. 3, AISI 304 stainless steel, reinforced	72.26	

Poly Fly 200 AISI 304 stainless steel sump unit without grating and accessories

Code	Description	Weight kg
4G23PI	AISI 304 stainless steel sump unit L 500 mm	61.20
4G22TI	AISI 304 stainless steel sheet end cap, thickness 20/10	1.12
4G22RI	AISI 304 stainless steel sheet end cap with outlet, thickness 20/10, Ø156 mm	1.85
4D10K	Anchoring kit for galvanised and AISI 304 stainless steel gratings (for gratings 1 - 4)	0.02
4D10A	Anchoring kit for AISI 304 stainless steel heelguard gratings (for gratings 2 - 3)	0.02
4D10P	Anchoring kit for AISI 304 stainless steel plates (for plate 5)	0.02

Poly Fly 200 channel (AISI 304 stainless steel edge rail) without grating - Length 1,000 mm

Channel L mm	Code	Description	Water passage mm	Run-off section cm ²	Weight kg	Pieces pallet
1,000	4G23S	Poly Fly 200 polymer concrete channel with AISI 304 stainless steel protective edge rail	223	448	30.12	24

POLYMER CONCRETE CHANNELS POLY FLY 200 Low

(galvanised edge rail)

Grating width 250 mm

Polymer concrete channel with galvanised edge rails complying with the UNI EN 1433 standard. The channels are sold exclusively in complete pallets and together with the gratings.

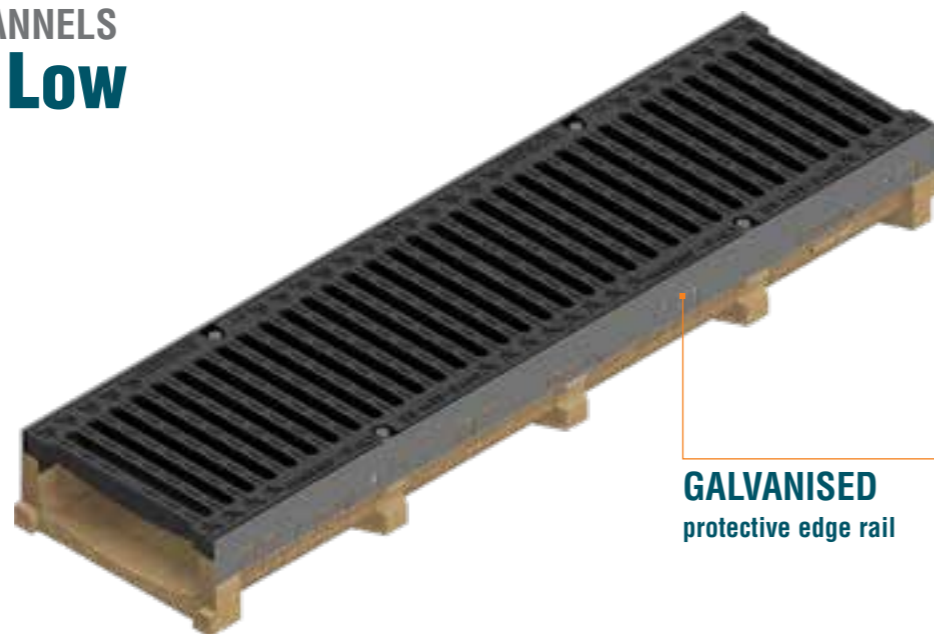

Poly Fly 200 Low channel dimensions

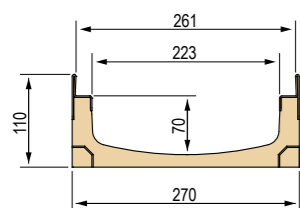

Available gratings

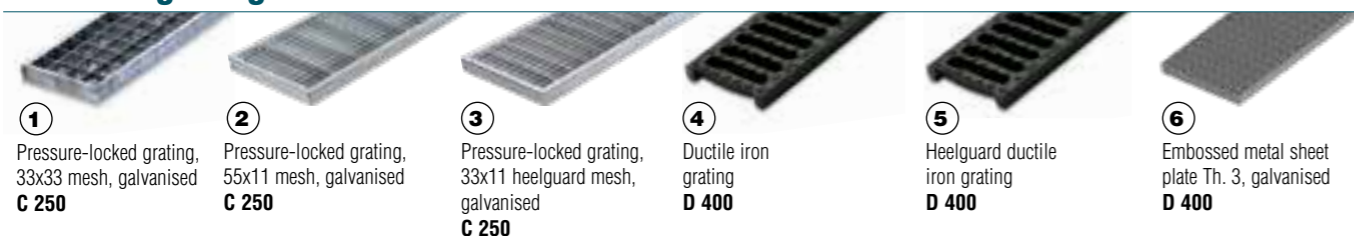

Poly Fly 200 Low channel (galvanised edge rail) complete with grating - Length 1,000 mm

WITH GALVANISED PROTECTIVE EDGE RAIL

Channel L mm	Code	Grating	Description of the channel assembled with the grating complete with accessories	Weight kg	Load class
1,000	4G2CSG1	①	Channel complete with pressure-locked grating with C-shaped edges, 25x2-10x2 33x33, hot-dip galvanised	22.15	C 250
	4G2CSG2	②	Channel complete with pressure-locked grating with C-shaped edges, 25x2-10x2 55x11 heelguard mesh, hot-dip galvanised	23.08	
	4G2CSG3	③	Channel complete with pressure-locked grating with C-shaped edges, 25x2-10x2 33x11 heelguard mesh, hot-dip galvanised	24.37	
	4G2CSGS	④	Channel complete with 2 x GJS500-7 ductile iron gratings	37.51	D 400
	4G2CSGSA	⑤	Channel complete with 2 x GJS500-7 ductile iron heelguard gratings	38.29	
	4G2CSP	⑥	Channel complete with embossed metal sheet solid plate Th. 3, reinforced and hot-dip galvanised	41.56	

Poly Fly 200 Low channel (galvanised edge rail) accessories

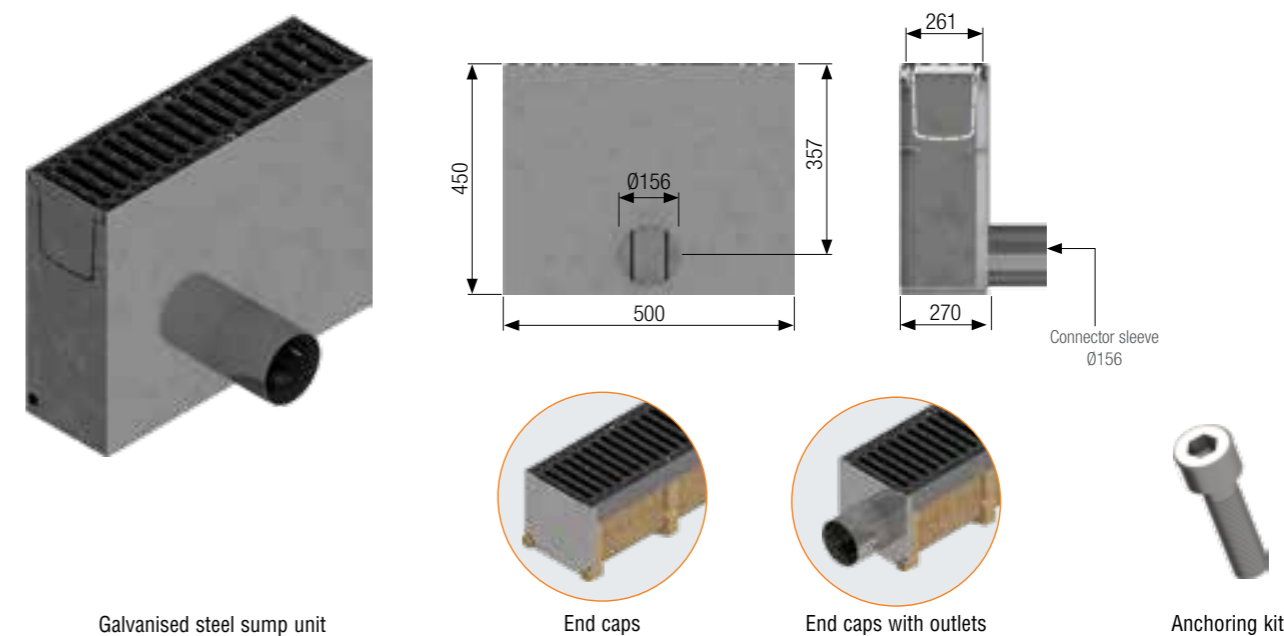

Poly Fly 200 Low galvanised steel sump unit complete with grating - Length 500 mm

Sump unit L mm	Code	Grating	Description of the channel assembled with the grating complete with accessories	Weight kg	Load class
500	4G22PZG1	①	Sump unit complete with pressure-locked grating with C-shaped edges, 25x2-10x2 33x33, hot-dip galvanised	62.55	C 250
	4G22PZG2	②	Sump unit complete with pressure-locked grating with C-shaped edges, 25x2-10x2 55x11 heelguard mesh, hot-dip galvanised	63.02	
	4G22PZG3	③	Sump unit complete with pressure-locked grating with C-shaped edges, 25x2-10x2 33x11, heelguard mesh, hot-dip galvanised	63.66	
	4G22PZGS	④	Sump unit complete with GJS500-7 ductile iron grating	70.23	D 400
	4G22PZGSA	⑤	Sump unit complete with GJS500-7 ductile iron heelguard grating	70.62	
	4G22PZP	⑥	Sump unit complete with embossed metal sheet solid plate Th. 3, reinforced and hot-dip galvanised	72.26	

Poly Fly 200 Low galvanised steel sump unit without grating and accessories

Code	Description	Weight kg
4G22PZ	Galvanised steel sump unit L 500 mm	61.20
4G2CTI	AISI 304 stainless steel sheet end cap, thickness 20/10	1.08
4G2CRI	AISI 304 stainless steel sheet end cap with outlet, thickness 20/10, Ø76 mm	1.74
4D10K	Anchoring kit for galvanised and AISI 304 stainless steel gratings (for gratings 1 - 2 - 3)	0.02
4D10V	Anchoring kit for ductile iron gratings (for gratings 4 - 5)	0.02
4D10P	Anchoring kit for galvanised and AISI 304 stainless steel plates (for plate 6)	0.02

Poly Fly 200 Low channel (galvanised edge rail) without grating - Length 1,000 mm

Channel L mm	Code	Description	Water passage mm	Run-off section cm ²	Weight kg	Pieces pallet
1,000	4G2CS	Poly Fly 200 Low polymer concrete channel with galvanised protective edge rail	223	137	17.74	32

POLYMER CONCRETE CHANNELS

POLY FLY 200 Low

(AISI 304 stainless steel edge rail)

Grating width 250 mm

Polymer concrete channel with stainless steel edge rails complying with the UNI EN 1433 standard. The channels are sold exclusively in complete pallets and together with the gratings.

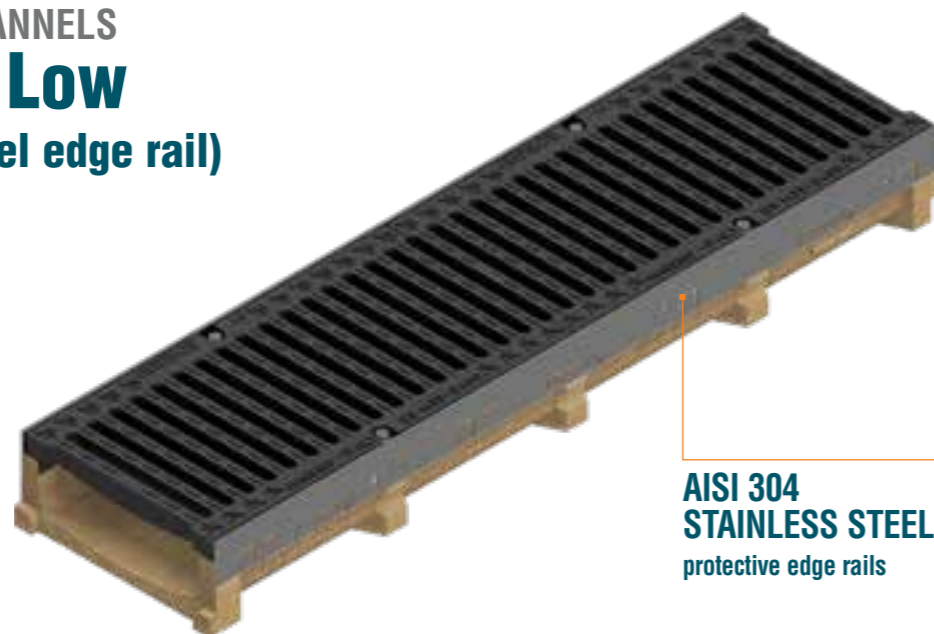

Poly Fly 200 Low channel dimensions

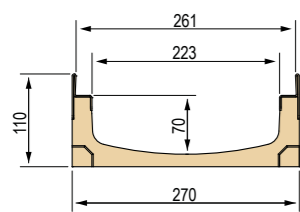

Available gratings



Poly Fly 200 Low channel (AISI 304 stainless steel edge rail) complete with grating - Length 1,000 mm

WITH AISI 304 STAINLESS STEEL PROTECTIVE EDGE RAIL

Channel L mm	Code	Grating	Description of the channel assembled with the grating complete with accessories	Weight kg	Load class
1,000	4G2DSX1	①	Channel complete with pressure-locked grating with edging, 25x2-10x2 33x33, AISI 304 stainless steel	22.35	C 250
	4G2DSX2	②	Channel complete with pressure-locked grating with edging, 25x2-10x2 55x11 heelguard mesh, AISI 304 stainless steel	23.15	
	4G2DSX3	③	Channel complete with pressure-locked grating with edging, 25x2-10x2 33x11 heelguard mesh, AISI 304 stainless steel	24.35	
	4G2DSX4	④	Channel complete with pressure-locked grating with edging, 25x3-10x2 25x25, AISI 304 stainless steel	25.55	D 400
	4G2DSPI	⑤	Channel complete with embossed metal sheet solid plate Th. 3, AISI 304 stainless steel, reinforced	41.56	

Poly Fly 200 Low channel (AISI 304 stainless steel edge rail) accessories

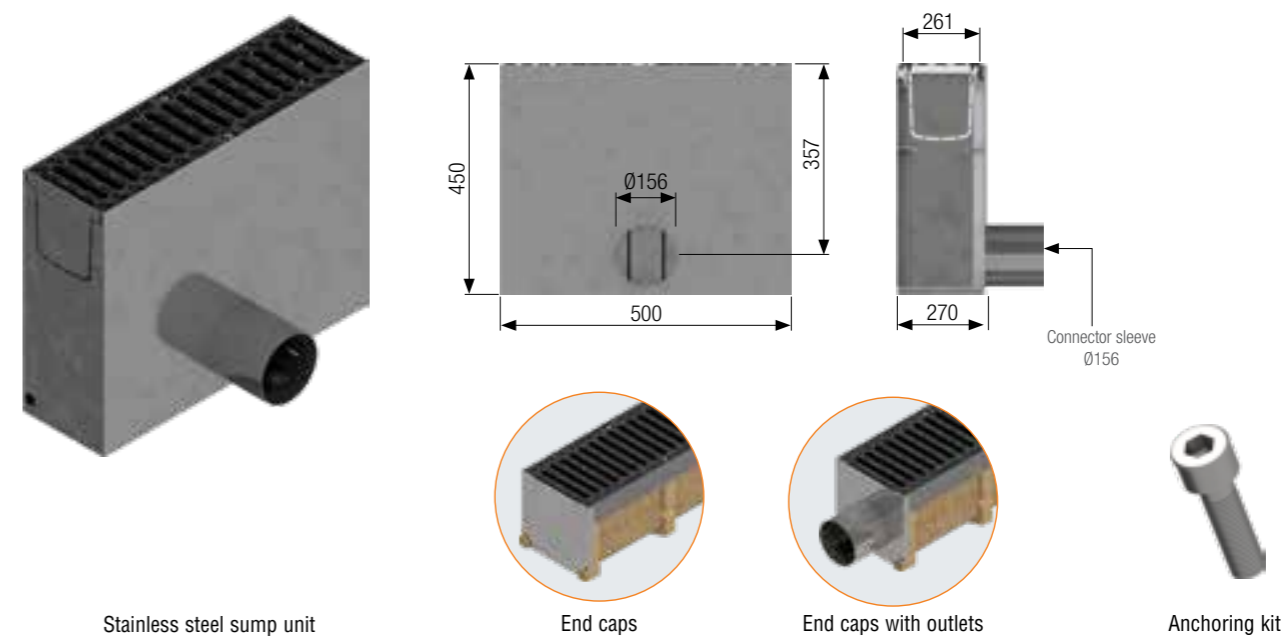

Poly Fly 200 Low AISI 304 stainless steel sump unit complete with grating - Length 500 mm

Sump unit L mm	Code	Grating	Description of the sump unit assembled with the grating complete with accessories	Weight kg	Load class
500	4G23PIX1	①	Sump unit complete with pressure-locked grating with edging, 25x2-10x2 33x33, AISI 304 stainless steel	62.65	C 250
	4G23PIX2	②	Sump unit complete with pressure-locked grating with edging, 25x2-10x2 55x11 heelguard mesh, AISI 304 stainless steel	63.05	
	4G23PIX3	③	Sump unit complete with pressure-locked grating with edging, 25x2-10x2 33x11 heelguard mesh, AISI 304 stainless steel	63.65	
	4G23PIX4	④	Sump unit complete with pressure-locked grating with edging, 25x3-10x2 25x25, AISI 304 stainless steel	64.25	D 400
	4G23PIPI	⑤	Sump unit complete with embossed metal sheet solid plate Th. 3, AISI 304 stainless steel, reinforced	72.26	

Poly Fly 200 Low AISI 304 stainless steel sump unit without grating and accessories

Code	Description	Weight kg
4G23PI	AISI 304 stainless steel sump unit L 500 mm	61.20
4G2CTI	AISI 304 stainless steel sheet end cap, thickness 20/10	1.08
4G2CRI	AISI 304 stainless steel sheet end cap with outlet, thickness 20/10, Ø76 mm	1.74
4D10K	Anchoring kit for galvanised and AISI 304 stainless steel gratings (for gratings 1 - 4)	0.02
4D10A	Anchoring kit for AISI 304 stainless steel heelguard gratings (for gratings 2 - 3)	0.02
4D10P	Anchoring kit for AISI 304 stainless steel plates (for plate 5)	0.02

Poly Fly 200 Low channel (AISI 304 stainless steel edge rail) without grating - Length 1,000 mm

Channel L mm	Code	Description	Water passage mm	Run-off section cm ²	Weight kg	Pieces pallet
1,000	4G2DS	Poly Fly 200 Low polymer concrete channel with AISI 304 stainless steel protective edge rail	223	137	18.01	32

POLYMER CONCRETE CHANNELS

POLY FLY 300 High

(galvanised edge rail)

Grating width 338 mm

Polymer concrete channel with galvanised edge rails complying with the UNI EN 1433 standard. The channels are sold exclusively in complete pallets and together with the gratings.



Poly Fly 300 High channel dimensions

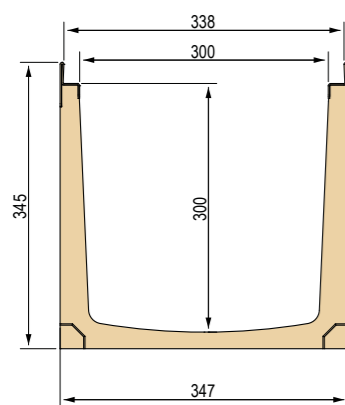

Available gratings

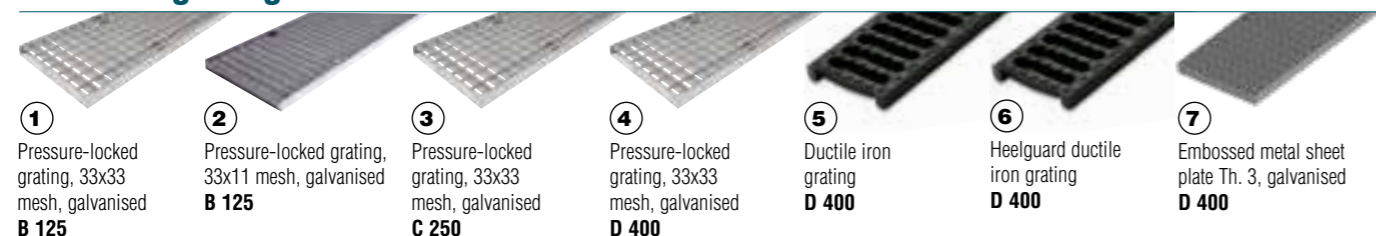

Poly Fly 300 High channel (galvanised edge rail) complete with grating - Length 1,000 mm

WITH GALVANISED PROTECTIVE EDGE RAIL

Channel L mm	Code	Grating	Description of the channel assembled with the grating complete with accessories	Weight kg	Load class
1,000	4G32SG1	①	Channel complete with pressure-locked grating 30x3-10x2 33x33, hot-dip galvanised	56.13	B 125
	4G32SG1A	②	Channel complete with pressure-locked grating 30x3-10x2 33x11 heelguard mesh, hot-dip galvanised	59.67	
	4G32SG2	③	Channel complete with pressure-locked grating 40x3-10x2 33x33, hot-dip galvanised	58.64	C 250
	4G32SG3	④	Channel complete with pressure-locked grating 50x3-10x2 33x33, hot-dip galvanised	61.14	D 400
	4G32SGS	⑤	Channel complete with 2 x GJS500-7 ductile iron gratings	75.15	
	4G32SGSA	⑥	Channel complete with 2 x GJS500-7 ductile iron heelguard gratings	79.55	
	4G32SP	⑦	Channel complete with embossed metal sheet solid plate Th. 3, reinforced and hot-dip galvanised	71.20	



Poly Fly 300 High channel (galvanised edge rail) accessories

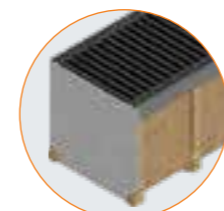

End cap for channels



End caps with outlets



Anchoring kit

Code	Description	Weight kg
4G32TI	AISI 304 stainless steel sheet end cap, Th. 20/10	1.12
4G32RI	AISI 304 stainless steel sheet end cap with outlet, Th. 20/10, Ø250 mm	2.20
4D32K	Anchoring kit for galvanised and AISI 304 stainless steel gratings (for gratings 1 - 2 - 3 - 4)	0.02
4D32V	Anchoring kit for ductile iron gratings (for gratings 5 - 6)	0.02
4D32P	Anchoring kit for galvanised and AISI 304 stainless steel plates (for plate 7)	0.02

Poly Fly 300 High channel (galvanised edge rail) without grating - Length 1,000 mm

Channel L mm	Code	Description	Water passage mm	Run-off section cm ²	Weight kg	Pieces pallet
1,000	4G32S	Poly Fly 300 High polymer concrete channel with galvanised protective edge rail	300	855	43.55	12

POLYMER CONCRETE CHANNELS

POLY FLY 300 High

(AISI 304 stainless steel edge rail)

Grating width 338 mm

Polymer concrete channel with stainless steel edge rails complying with the UNI EN 1433 standard. The channels are sold exclusively in complete pallets and together with the gratings.



Poly Fly 300 High channel dimensions

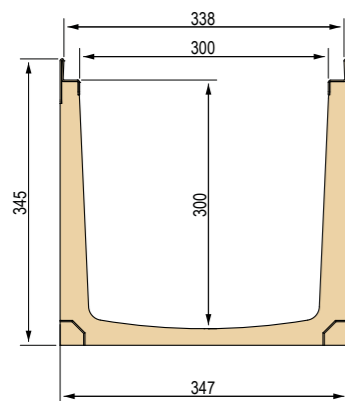

Available gratings

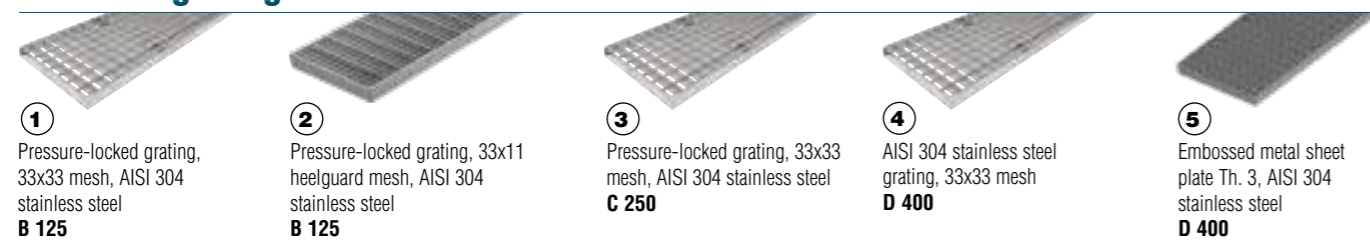

Poly Fly 300 High channel (AISI 304 stainless steel edge rail) complete with grating - Length 1,000 mm

WITH AISI 304 STAINLESS STEEL PROTECTIVE EDGE RAIL

Channel L mm	Code	Grating	Description of the channel assembled with the grating complete with accessories	Weight kg	Load class
1,000	4G33SX1	①	Channel complete with pressure-locked grating with edging, 30x3-10x2 33x33, AISI 304 stainless steel	56.13	B 125
	4G33SX2	②	Channel complete with pressure-locked grating, 30x3-10x2 33x11 heelguard mesh, AISI 304 stainless steel	59.67	
	4G33SX3	③	Channel complete with pressure-locked grating, 40x3-10x2 33x33, AISI 304 stainless steel	58.64	C 250
	4G33SX4	④	Channel complete with pressure-locked grating, 50x3-10x2 33x33, AISI 304 stainless steel	61.14	D 400
	4G33SPI	⑤	Channel complete with embossed metal sheet solid plate Th. 3, AISI 304 stainless steel	71.71	



Poly Fly 300 High channel (AISI 304 stainless steel edge rail) accessories



Code	Description	Weight kg
4G32TI	AISI 304 stainless steel sheet end cap, Th. 20/10	1.12
4G32RI	AISI 304 stainless steel sheet end cap with outlet, Th. 20/10, Ø250 mm	2.20
4D32K	Anchoring kit for galvanised and AISI 304 stainless steel gratings (for gratings 1 - 3 - 4)	0.02
4D32A	Anchoring kit for AISI 304 stainless steel heelguard gratings (for grating 2)	0.02
4D32P	Anchoring kit for AISI 304 stainless steel plate (for plate 5)	0.02

Poly Fly 300 High channel (AISI 304 stainless steel edge rail) without grating - Length 1,000 mm

Channel L mm	Code	Description	Water passage mm	Run-off section cm ²	Weight kg	Pieces pallet
1,000	4G33S	Poly Fly 300 High polymer concrete channel with AISI 304 stainless steel protective edge rail	300	855	43.55	12

POLYMER CONCRETE CHANNELS

POLY FLY 300 Medium

(galvanised edge rail)

Grating width 338 mm

Polymer concrete channel with galvanised edge rails complying with the UNI EN 1433 standard. The channels are sold exclusively in complete pallets and together with the gratings.



GALVANISED
protective edge rail



Poly Fly 300 Medium channel dimensions

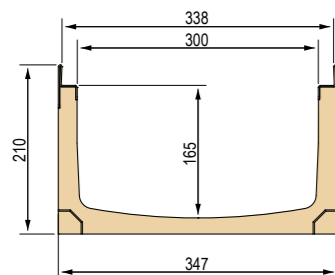

Available gratings

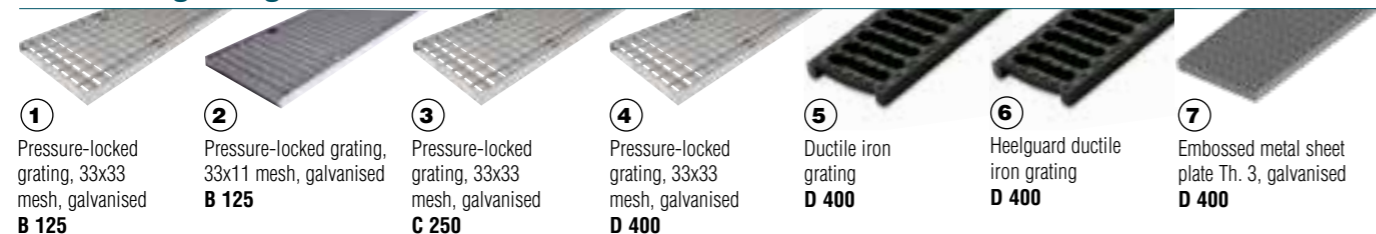

Poly Fly 300 Medium channel (galvanised edge rail) complete with grating - Length 1,000 mm

WITH GALVANISED PROTECTIVE EDGE RAIL

Channel L mm	Code	Grating	Description of the channel assembled with the grating complete with accessories	Weight kg	Load class
1,000	4G3ESG1	①	Channel complete with pressure-locked grating 30x3-10x2 33x33, hot-dip galvanised	43.78	B 125
	4G3ESG1A	②	Channel complete with pressure-locked grating 30x3-10x2 33x11 heelguard mesh, hot-dip galvanised	47.32	
	4G3ESG2	③	Channel complete with pressure-locked grating 40x3-10x2 33x33, hot-dip galvanised	46.29	C 250
	4G3ESG3	④	Channel complete with pressure-locked grating 50x3-10x2 33x33, hot-dip galvanised	48.79	D 400
	4G3ESGS	⑤	Channel complete with 2 x GJS500-7 ductile iron gratings	64.62	
	4G3ESGSA	⑥	Channel complete with 2 x GJS500-7 ductile iron heelguard gratings	65.65	
	4G3ESP	⑦	Channel complete with embossed metal sheet solid plate Th. 3, reinforced and hot-dip galvanised	58.85	

Poly Fly 300 Medium channel (galvanised edge rail) accessories

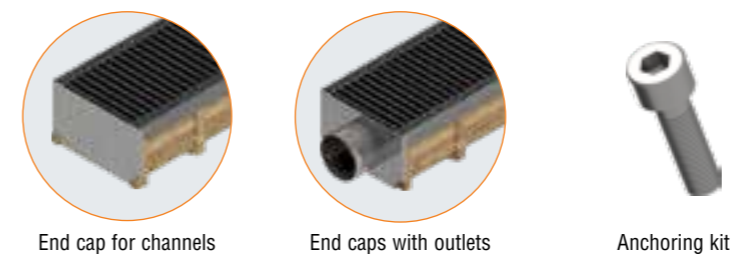

End cap for channels

End caps with outlets

Anchoring kit

Code	Description	Weight kg
4G3ETI	AISI 304 stainless steel sheet end cap, Th. 20/10	1.08
4G3ERI	AISI 304 stainless steel sheet end cap with outlet, Th. 20/10, Ø156 mm	2.15
4D32K	Anchoring kit for galvanised and AISI 304 stainless steel gratings (for gratings 1 - 2 - 3 - 4)	0.02
4D32V	Anchoring kit for ductile iron gratings (for gratings 5 - 6)	0.02
4D32P	Anchoring kit for galvanised/AISI 304 stainless steel plates (for plate 7)	0.02

Poly Fly 300 Medium channel (galvanised edge rail) without grating - Length 1,000 mm

Channel L mm	Code	Description	Water passage mm	Run-off section cm ²	Weight kg	Pieces pallet
1,000	4G3ES	Poly Fly 300 Medium polymer concrete channel with galvanised protective edge rail	300	477	31.20	18

POLYMER CONCRETE CHANNELS

POLY FLY 300 Medium

(AISI 304 stainless steel edge rail)

Grating width 338 mm

Polymer concrete channel with stainless steel edge rails complying with the UNI EN 1433 standard. The channels are sold exclusively in complete pallets and together with the gratings.

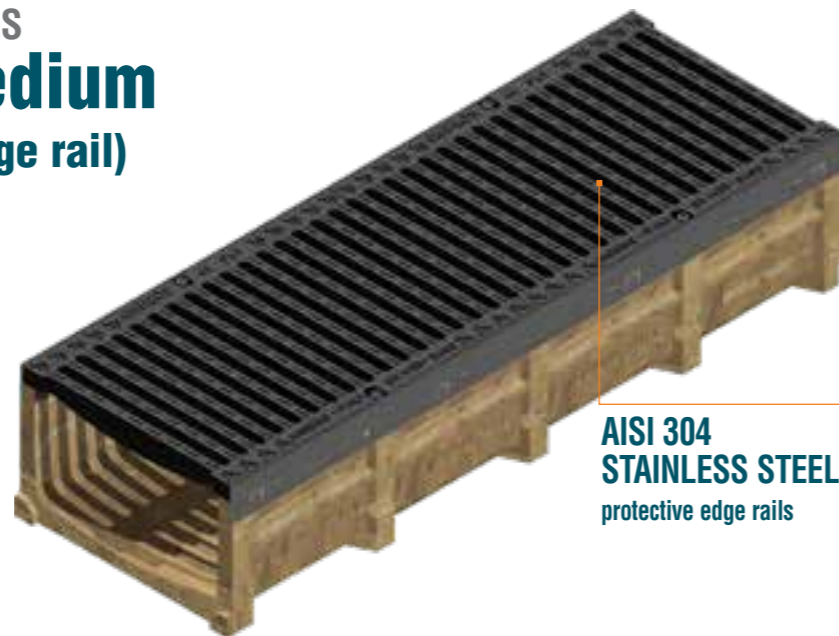

AISI 304 STAINLESS STEEL
protective edge rails



Poly Fly 300 Medium channel dimensions

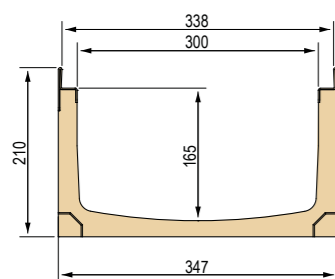

Available gratings

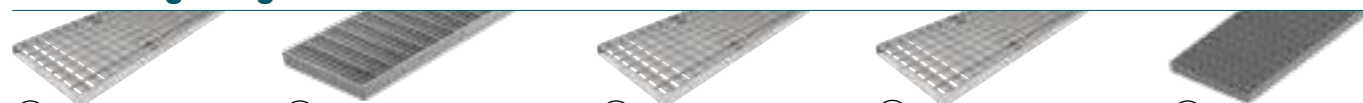

① Pressure-locked grating, 33x33 mesh, AISI 304 stainless steel
B 125

② Pressure-locked grating, 33x11 heelguard mesh, AISI 304 stainless steel
B 125

③ Pressure-locked grating, 33x33 mesh, AISI 304 stainless steel
C 250

④ AISI 304 stainless steel grating, 33x33 mesh
D 400

⑤ Embossed metal sheet plate Th. 3, AISI 304 stainless steel
D 400

Poly Fly 300 Medium channel (AISI 304 stainless steel edge rail) complete with grating - Length 1,000 mm

WITH AISI 304 STAINLESS STEEL PROTECTIVE EDGE RAIL

Channel L mm	Code	Grating	Description of the channel assembled with the grating complete with accessories	Weight kg	Load class
1,000	4G3FSX1	①	Channel complete with pressure-locked grating with edging, 30x3-10x2 33x33, AISI 3043 stainless steel	43.78	B 125
	4G3FSX2	②	Channel complete with pressure-locked grating, 30x3-10x2 33x11 heelguard mesh, AISI 304 stainless steel	47.32	
	4G3FSX3	③	Channel complete with pressure-locked grating, 40x3-10x2 33x33, AISI 304 stainless steel	46.29	C 250
	4G3FSX4	④	Channel complete with pressure-locked grating, 50x3-10x2 33x33, AISI 304 stainless steel	48.79	D 400
	4G3FSPI	⑤	Channel complete with embossed metal sheet solid plate Th. 3, AISI 304 stainless steel	59.36	

Poly Fly 300 Medium channel (AISI 304 stainless steel edge rail) accessories

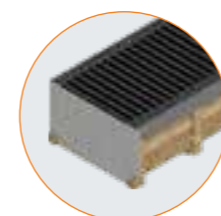

End cap for channels



End caps with outlets



Anchoring kit

Code	Description	Weight kg
4G3ETI	AISI 304 stainless steel sheet end cap, Th. 20/10	1.08
4G3ERI	AISI 304 stainless steel sheet end cap with outlet, Th. 20/10, Ø156 mm	2.15
4D32K	Anchoring kit for galvanised and AISI 304 stainless steel gratings (for gratings 1 - 3 - 4)	0.02
4D32A	Anchoring kit for AISI 304 stainless steel heelguard gratings (for grating 2)	0.02
4D32P	Anchoring kit for AISI 304 stainless steel plate (for plate 5)	0.02

Poly Fly 300 Medium channel (AISI 304 stainless steel edge rail) without grating - Length 1,000 mm

Channel L mm	Code	Description	Water passage mm	Run-off section cm ²	Weight kg	Pieces pallet
1,000	4G3FS	Poly Fly 300 Medium polymer concrete channel with AISI 304 stainless steel protective edge rail	300	477	31.20	18

POLYMER CONCRETE CHANNELS

POLY FLY 300 Low

(galvanised edge rail)

Grating width 338 mm

Polymer concrete channel with galvanised edge rails complying with the UNI EN 1433 standard. The channels are sold exclusively in complete pallets and together with the gratings.



GALVANISED
protective edge rail



Poly Fly 300 Low channel dimensions

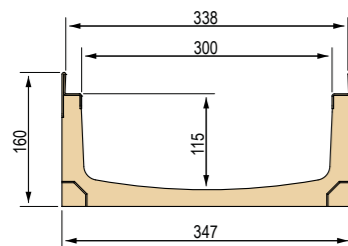

Available gratings

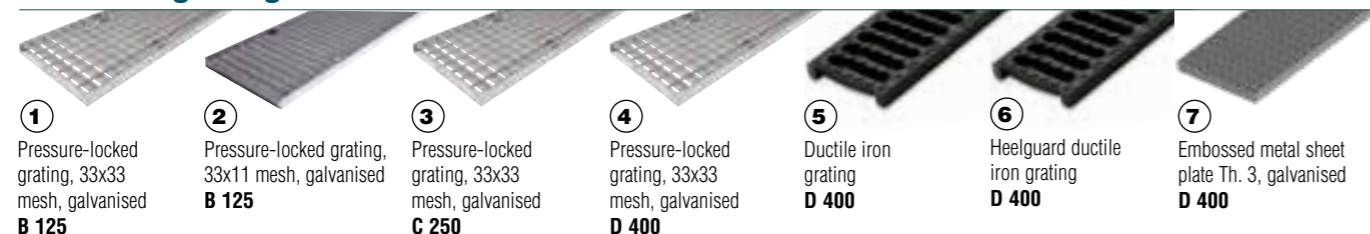

Poly Fly 300 Low channel (galvanised edge rail) complete with grating - Length 1,000 mm

WITH GALVANISED PROTECTIVE EDGE RAIL

Channel L mm	Code	Grating	Description of the channel assembled with the grating complete with accessories	Weight kg	Load class
1,000	4G3CSG1	①	Channel complete with pressure-locked grating 30x3-10x2 33x33, hot-dip galvanised	39.53	B 125
	4G3CSG1A	②	Channel complete with pressure-locked grating 30x3-10x2 33x11 heelguard mesh, hot-dip galvanised	43.07	
	4G3CSG2	③	Channel complete with pressure-locked grating 40x3-10x2 33x33, hot-dip galvanised	42.04	C 250
	4G3CSG3	④	Channel complete with pressure-locked grating 50x3-10x2 33x33, hot-dip galvanised	44.54	D 400
	4G3CSGS	⑤	Channel complete with 2 x GJS500-7 ductile iron gratings	58.55	
	4G3CSGSA	⑥	Channel complete with 2 x GJS500-7 ductile iron heelguard gratings	60.75	
	4G3CSP	⑦	Channel complete with embossed metal sheet solid plate Th. 3, reinforced and hot-dip galvanised	54.60	

Poly Fly 300 Low channel (galvanised edge rail) accessories

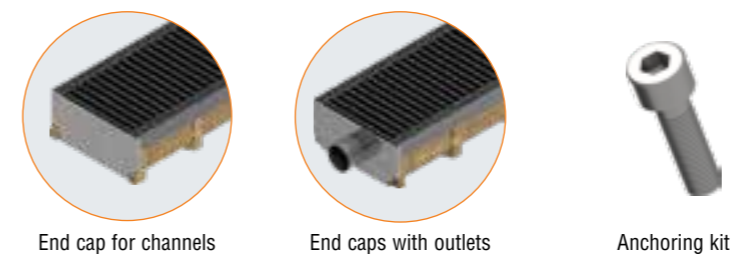

End cap for channels

End caps with outlets

Anchoring kit

Code	Description	Weight kg
4G3CTI	AISI 304 stainless steel sheet end cap, Th. 20/10	1.05
4G3CRI	AISI 304 stainless steel sheet end cap with outlet, Th. 20/10, Ø89 mm	2.06
4D32K	Anchoring kit for galvanised and AISI 304 stainless steel gratings (for gratings 1 - 2 - 3 - 4)	0.02
4D32V	Anchoring kit for ductile iron gratings (for gratings 5 - 6)	0.02
4D32P	Anchoring kit for galvanised/AISI 304 stainless steel plates (for plate 7)	0.02

Poly Fly 300 Low channel (galvanised edge rail) without grating - Length 1,000 mm

Channel L mm	Code	Description	Water passage mm	Run-off section cm ²	Weight kg	Pieces pallet
1,000	4G3CS	Poly Fly 300 Low polymer concrete channel with galvanised protective edge rail	300	327	26.95	21

POLYMER CONCRETE CHANNELS

POLY FLY 300 Low

(AISI 304 stainless steel edge rail)

Grating width 338 mm

Polymer concrete channel with AISI 304 stainless steel edge rails complying with the UNI EN 1433 standard. The channels are sold exclusively in complete pallets and together with the gratings.

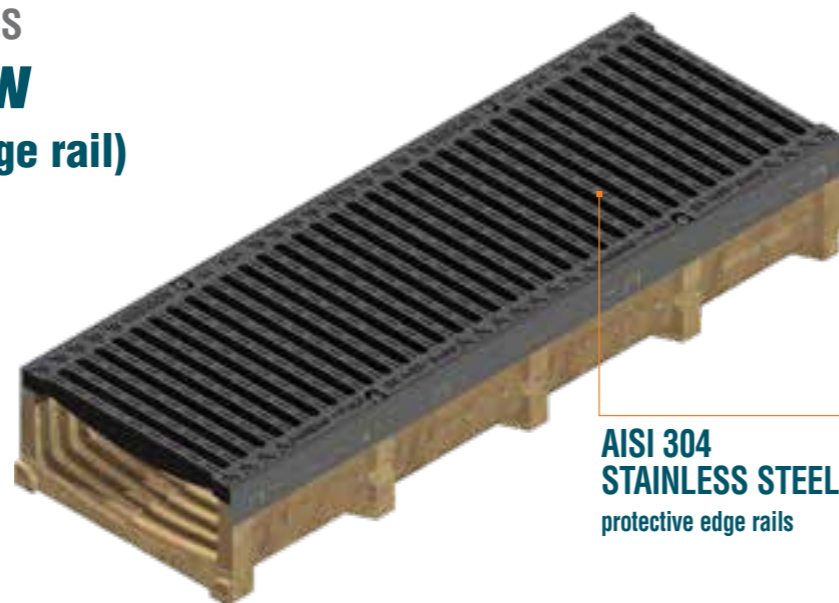

AISI 304 STAINLESS STEEL
protective edge rails



Poly Fly 300 Low channel dimensions

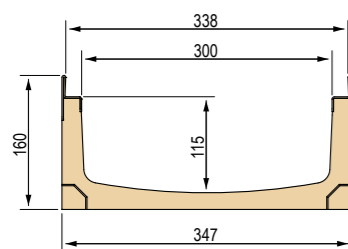

Available gratings



Poly Fly 300 Low channel (AISI 304 stainless steel edge rail) complete with grating - Length 1,000 mm

WITH AISI 304 STAINLESS STEEL PROTECTIVE EDGE RAIL

Channel L mm	Code	Grating	Description of the channel assembled with the grating complete with accessories	Weight kg	Load class
1,000	4G3DSX1	①	Channel complete with pressure-locked grating with edging, 30x3-10x2 33x33, AISI 304 stainless steel	39.53	B 125
	4G3DSX2	②	Channel complete with pressure-locked grating, 30x3-10x2 33x11 heelguard mesh, AISI 304 stainless steel	43.07	
	4G3DSX3	③	Channel complete with pressure-locked grating, 40x3-10x2 33x33, AISI 304 stainless steel	42.04	C 250
	4G3DSX4	④	Channel complete with pressure-locked grating, 50x3-10x2 33x33, AISI 304 stainless steel	44.54	D 400
	4G3DSPI	⑤	Channel complete with embossed metal sheet solid plate Th. 3, AISI 304 stainless steel	55.11	

Poly Fly 300 Low channel (AISI 304 stainless steel edge rail) accessories

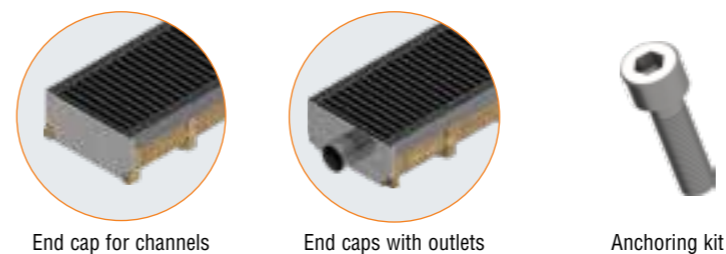

End cap for channels End caps with outlets Anchoring kit

Code	Description	Weight kg
4G3CTI	AISI 304 stainless steel sheet end cap, Th. 20/10	1.05
4G3CRI	AISI 304 stainless steel sheet end cap with outlet, Th. 20/10, Ø89 mm	2.06
4D32K	Anchoring kit for galvanised and AISI 304 stainless steel gratings (for gratings 1 - 3 - 4)	0.02
4D32A	Anchoring kit for AISI 304 stainless steel heelguard gratings (for grating 2)	0.02
4D32P	Anchoring kit for galvanised/AISI 304 stainless steel plates (for plate 5)	0.02

Poly Fly 300 Low channel (AISI 304 stainless steel edge rail) without grating - Length 1,000 mm

Channel L mm	Code	Description	Water passage mm	Run-off section cm ²	Weight kg	Pieces pallet
1,000	4G3DS	Poly Fly 300 Low polymer concrete channel with AISI 304 stainless steel protective edge rail	300	327	26.95	21

ABS CHANNELS

GRIDIRON®



PAGE
242
PLASTIC FLY SERIES

GRIDIRON®
BUILD YOUR CHANGES

ABS CHANNELS

ABS CHANNELS

PLASTIC FLY SERIES

ABS is an acronym identifying a family of thermoplastic materials. The acronym derives from the three monomers used in producing ABS, namely acrylonitrile, butadiene and styrene. The Plastic Fly Series ABS drainage channels manufactured by Gridiron are renowned for their excellent mechanical resistance to shocks and impact and their ease of installation.

The manifold engineering advantages offered by ABS derive from the properties contributed by the individual components. Acrylonitrile enhances thermal and chemical resistance and tenacity, butadiene increases resistance to shocks and maintains the low modulus properties, while styrene provides surface gloss, rigidity and workability.

ADVANTAGES AND FEATURES

Recyclability: product made of 100% recycled plastic which can in turn be recycled.

Lightness: large quantities can be transported in tight spaces.

Roughness: its smooth and impermeable surface enables water to flow with less friction.

Installation: its lightness facilitates installation by eliminating the need for working machines.

Geometrical structure: the channel guarantees maximum stability and easy connection, thanks to the lateral reinforcement ribbing, the male/female configuration (for joining purposes) and the drain connection.

Durability: the chemical composition is specially formulated for improving reliability and durability, by countering typical degrading agents such as micro-organisms, light, petroleum products and waste water.

Hazardous ingredients: This product does not correspond to the definition of dangerous preparations pursuant to Directive 1999/45/EC and subsequent amendments.



- PLASTIC FLY 100
- PLASTIC FLY 100 LOW
- PLASTIC FLY 150
- PLASTIC FLY 150 LOW
- PLASTIC FLY 200
- PLASTIC FLY 200 LOW

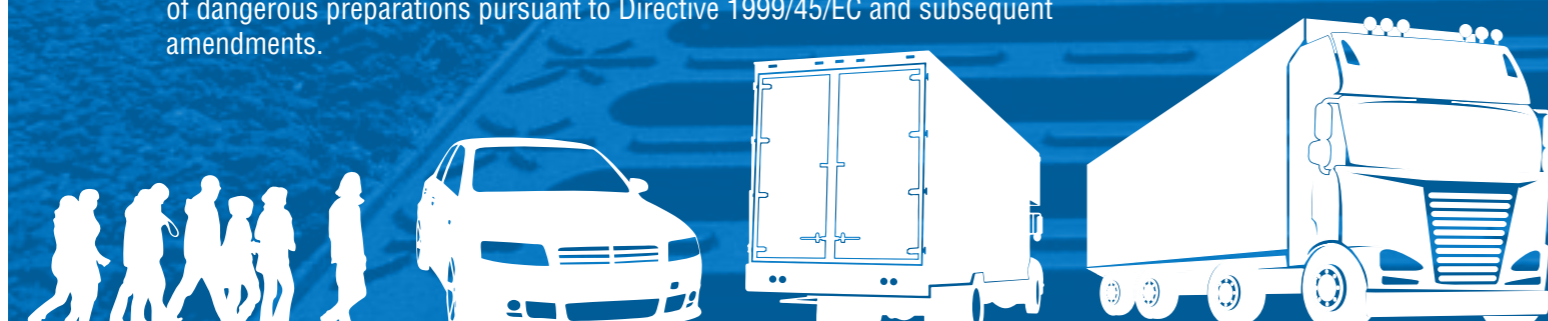

LOAD CLASSES

In accordance with the UNI EN 1433 standard



A 15 • C 250 • D 400

ABS CHANNELS PLASTIC FLY SERIES SYSTEM AND TECHNICAL CHARACTERISTICS

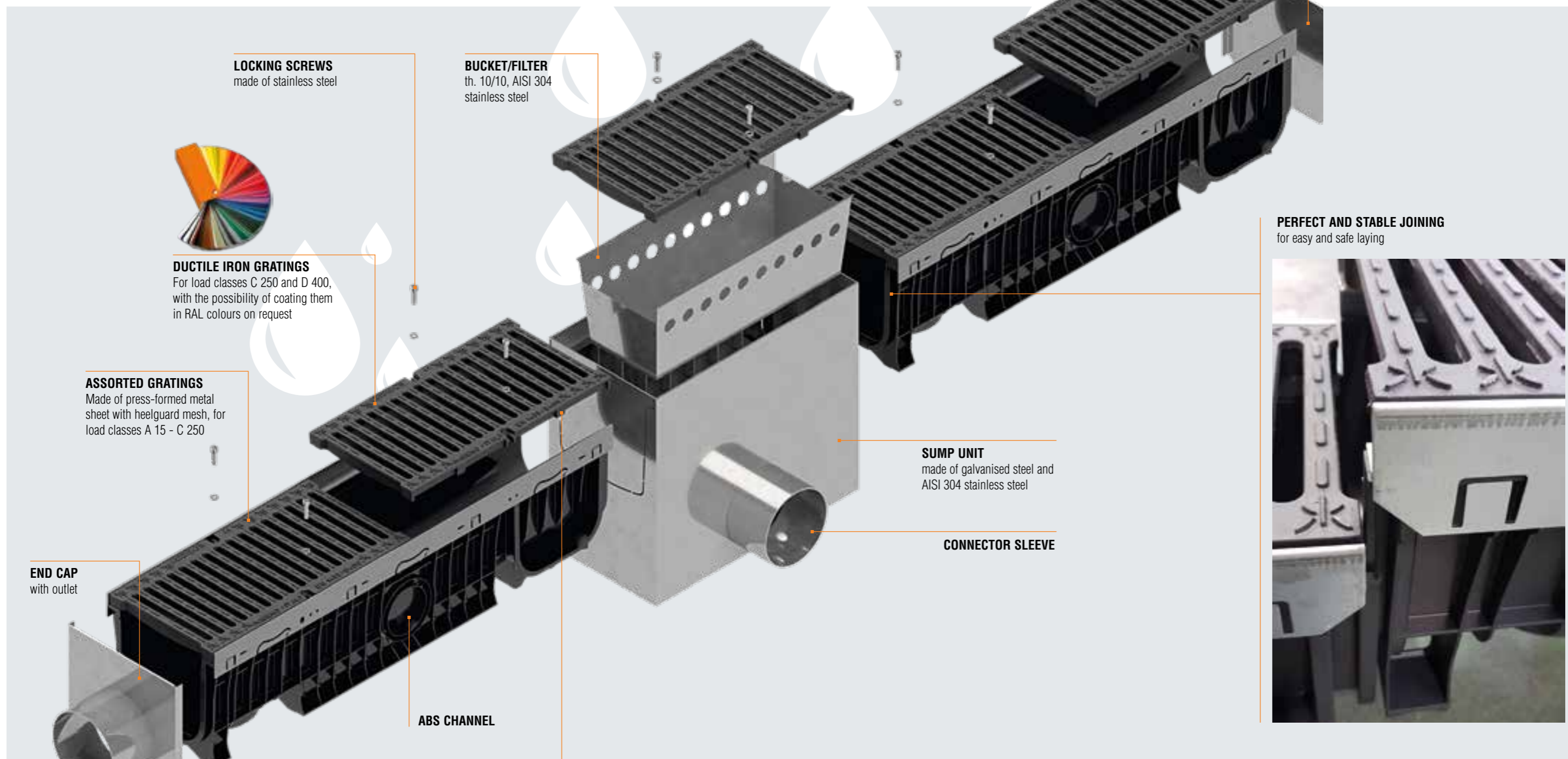

LOCKING SCREWS
made of stainless steel

BUCKET/FILTER
th. 10/10, AISI 304
stainless steel



DUCTILE IRON GRATINGS
For load classes C 250 and D 400,
with the possibility of coating them
in RAL colours on request

ASSORTED GRATINGS
Made of press-formed metal
sheet with heelguard mesh, for
load classes A 15 - C 250

END CAP
with outlet

ABS CHANNEL

SUMP UNIT
made of galvanised steel and
AISI 304 stainless steel

CONNECTOR SLEEVE

END CAP
for channel

PERFECT AND STABLE JOINING
for easy and safe laying



DUCTILE IRON GRATINGS SECURED TO THE CHANNEL
The ductile iron gratings secured to the channel have four relief notches along their lower section which slot into the relative housings on the protective edge rail of the channel to prevent their longitudinal movement.



ABS CHANNELS PLASTIC FLY 100

Grating width 150 mm

ABS channel available in various versions for housing the grating: without edge rails, with ABS edge rails or with metal edge rails, complying with the UNI EN 1433 standard. The channels are sold exclusively in complete pallets and together with the gratings.



Dimensions of the Plastic Fly 100 channel based on the type of edge rail used

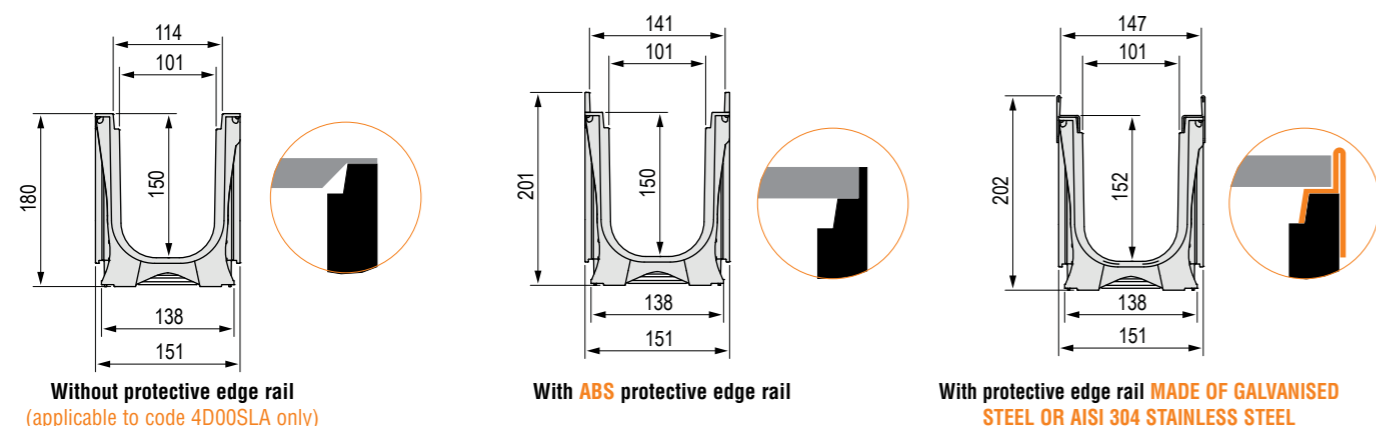

Available gratings

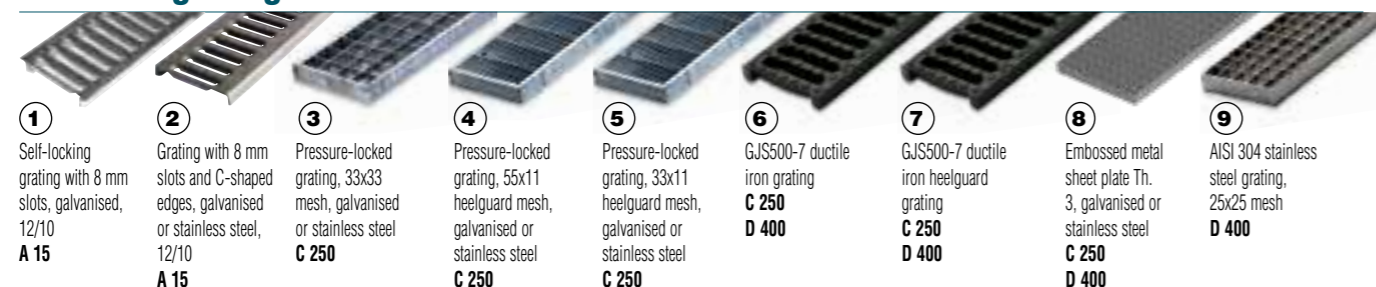

Plastic Fly 100 channel complete with grating - Length 1,000 mm

WITHOUT PROTECTIVE EDGE RAIL

Channel L mm	Code	Grating	Description of the channel assembled with the grating complete with accessories	Weight kg	Load class
1,000	4D00SLA	①	Channel complete with self-locking press-formed metal sheet inlay grating 12/10, galvanised	4.19	A 15

WITH ABS PROTECTIVE EDGE RAIL

Channel L mm	Code	Grating	Description of the channel assembled with the grating complete with accessories	Weight kg	Load class
1,000	4D01SLC	②	Channel complete with galvanised press-formed metal sheet grating 12/10 with C-shaped edges	4.28	A 15
	4D01SG1	③	Channel complete with pressure-locked grating with C-shaped edges, 20x2-10x2 33x33, hot-dip galvanised	5.00	
	4D01SG2	④	Channel complete with pressure-locked grating with C-shaped edges, 20x2-10x2 55x11 heelguard mesh, hot-dip galvanised	5.70	C 250
	4D01SG3	⑤	Channel complete with pressure-locked grating with C-shaped edges, 20x2-10x2 33x11 heelguard mesh, hot-dip galvanised	6.27	
	4D01SGS	⑥	Channel complete with 2 x GJS500-7 ductile iron gratings	10.36	
	4D01SGSA	⑦	Channel complete with 2 x GJS500-7 ductile iron heelguard gratings	12.42	
	4D01SP	⑧	Channel complete with embossed metal sheet solid plate Th. 3, reinforced and hot-dip galvanised	12.71	

WITH GALVANISED PROTECTIVE EDGE RAIL

Channel L mm	Code	Grating	Description of the channel assembled with the grating complete with accessories	Weight kg	Load class
1,000	4D02SLC	②	Channel complete with galvanised press-formed metal sheet grating 12/10 with C-shaped edges	6.85	A 15
	4D02SG1	③	Channel complete with pressure-locked grating with C-shaped edges, 20x2-10x2 33x33, hot-dip galvanised	7.57	
	4D02SG2	④	Channel complete with pressure-locked grating with C-shaped edges, 20x2-10x2 55x11 heelguard mesh, hot-dip galvanised	8.27	C 250
	4D02SG3	⑤	Channel complete with pressure-locked grating with C-shaped edges, 20x2-10x2 33x11 heelguard mesh, hot-dip galvanised	8.84	
	4D02SGS	⑥	Channel complete with 2 x GJS500-7 ductile iron gratings	12.93	D 400
	4D02SGSA	⑦	Channel complete with 2 x GJS500-7 ductile iron heelguard gratings	14.99	
	4D02SP	⑧	Channel complete with embossed metal sheet solid plate Th. 3, reinforced and hot-dip galvanised	15.28	

WITH AISI 304 STAINLESS STEEL PROTECTIVE EDGE RAIL

Channel L mm	Code	Grating	Description of the channel assembled with the grating complete with accessories	Weight kg	Load class
1,000	4D03SLCI	②	Channel complete with AISI 304 stainless steel press-formed metal sheet grating 12/10 with C-shaped edges	6.91	A 15
	4D03SX1	③	Channel complete with pressure-locked grating with edging, 20x2-10x2 33x33, AISI 304 stainless steel	8.58	
	4D03SX2	④	Channel complete with pressure-locked grating with edging, 20x2-10x2 55x11 heelguard mesh, AISI 304 stainless steel	8.83	C 250
	4D03SX3	⑤	Channel complete with pressure-locked grating with edging, 20x2-10x2 33x11 heelguard mesh, AISI 304 stainless steel	8.63	
	4D03SPI	⑧	Channel complete with embossed metal sheet solid plate Th. 3, AISI 304 stainless steel, reinforced	15.28	D 400
	4D03SX4	⑨	Channel complete with pressure-locked grating with edging, 20x3-10x2 25x25, AISI 304 stainless steel	9.39	

Plastic Fly 100 channel accessories



Code	Description	Weight kg
4D00TI	End cap made of AISI 304 stainless steel sheet Th. 15/10 for Plastic Fly 100 channel without edge rail	0.48
4D01TI	End cap made of AISI 304 stainless steel sheet Th. 15/10 for Plastic Fly 100 channel with edge rail	0.52
4D00RI	End cap with outlet made of AISI 304 stainless steel sheet Th. 15/10 for Plastic Fly 100 channel without edge rail, Ø89 mm	1.15
4D01RI	End cap with outlet made of AISI 304 stainless steel sheet thickness 15/10 for Plastic Fly 100 channel with edge rail, Ø89 mm	1.23
4D00K	Anchoring kit for galvanised gratings	0.02
4D00V	Anchoring kit for stainless steel and ductile iron gratings, and for galvanised and stainless steel plates	0.02

Plastic Fly 100 channel without grating - Length 1,000 mm

Channel L mm	Code	Description	Water passage mm	Run-off section cm ²	Weight kg	Pieces pallet
1,000	4D00S	Plastic Fly 100 ABS channel	100	142	2.21	42
	4D01S	Plastic Fly 100 ABS channel with ABS protective edge rail	100	142	2.46	42
	4D02S	Plastic Fly 100 ABS channel with galvanised protective edge rail	100	142	5.03	42
	4D03S	Plastic Fly 100 ABS channel with AISI 304 stainless steel edge rail	100	142	5.03	42

ABS CHANNELS PLASTIC FLY 100 WITH THIN COVER

(for channels with ABS, galvanised and stainless steel edge rail)

CENTRAL SLOT

ABS channel with ABS, galvanised and stainless steel edge rails complying with the UNI EN 1433 standard. The channels are sold exclusively in complete pallets and together with the gratings.

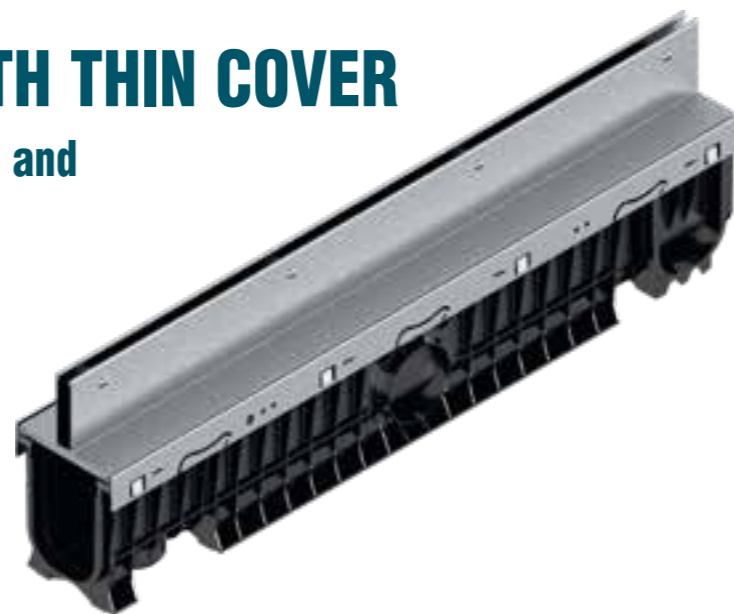

Plastic Fly 100 channel dimensions

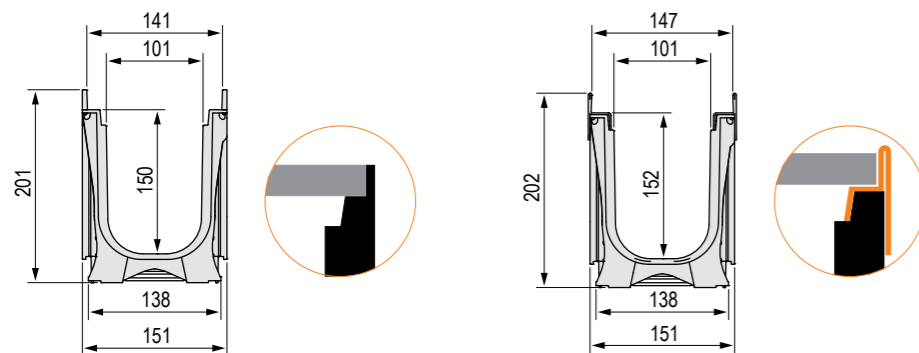

With **ABS** protective edge rail

With protective edge rail **MADE OF GALVANISED STEEL OR AISI 304 STAINLESS STEEL**

Available Thin covers

N.B.: available on request with 10 mm heelguard slot and in AISI 316 stainless steel

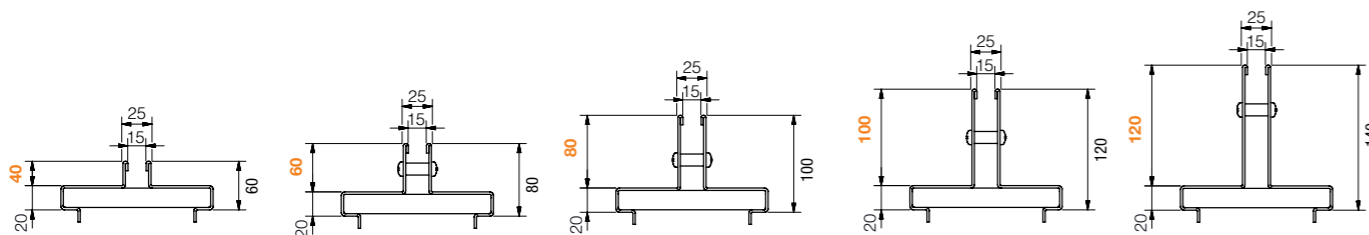

Plastic Fly 100 channel without grating - Length 1,000

Channel L mm	Code	Description	Water passage mm	Run-off section cm ²	Weight kg	Pieces pallet
1,000	4D01S	Plastic Fly 100 ABS channel with ABS protective edge rail	100	142	2.46	loose
	4D02S	Plastic Fly 100 ABS channel with galvanised protective edge rail	100	142	5.03	loose
	4D03S	Plastic Fly 100 ABS channel with AISI 304 stainless steel edge rail	100	142	5.03	loose



Thin covers with central slot - Slot width 15 mm

GALVANISED

Cover L mm	Code	Description	Slot height mm	Weight kg	Load class
1,000	4G02T0	Thin central cover, hot-dip galvanised, Th. 20/10	40	5.28	C 250
	4G02T	Thin central cover, hot-dip galvanised, Th. 20/10	60	5.91	
	4G02T1	Thin central cover, hot-dip galvanised, Th. 20/10	80	6.54	D 400
	4G02T2	Thin central cover, hot-dip galvanised, Th. 20/10	100	7.17	
	4G02T3	Thin central cover, hot-dip galvanised, Th. 20/10	120	7.29	
500	4G05T0	Thin central cover, hot-dip galvanised, Th. 20/10	40	2.63	C 250
	4G05T	Thin central cover, hot-dip galvanised, Th. 20/10	60	2.95	
	4G05T1	Thin central cover, hot-dip galvanised, Th. 20/10	80	3.27	D 400
	4G05T2	Thin central cover, hot-dip galvanised, Th. 20/10	100	3.58	
	4G05T3	Thin central cover, hot-dip galvanised, Th. 20/10	120	3.90	

N.B.: the Thin cover is supplied loose

AISI 304 STAINLESS STEEL

Cover L mm	Code	Description	Slot height mm	Weight kg	Load class
1,000	4G03I0	Thin central cover made of AISI 304 stainless steel Th. 20/10	40	5.28	C 250
	4G03I	Thin central cover made of AISI 304 stainless steel Th. 20/10	60	5.91	
	4G03I1	Thin central cover made of AISI 304 stainless steel Th. 20/10	80	6.54	D 400
	4G03I2	Thin central cover made of AISI 304 stainless steel Th. 20/10	100	7.17	
	4G03I3	Thin central cover made of AISI 304 stainless steel Th. 20/10	120	7.29	
500	4G05I0	Thin central cover made of AISI 304 stainless steel Th. 20/10	40	2.63	C 250
	4G05I	Thin central cover made of AISI 304 stainless steel Th. 20/10	60	2.95	
	4G05I1	Thin central cover made of AISI 304 stainless steel Th. 20/10	80	3.27	D 400
	4G05I2	Thin central cover made of AISI 304 stainless steel Th. 20/10	100	3.58	
	4G05I3	Thin central cover made of AISI 304 stainless steel Th. 20/10	120	3.90	

N.B.: the Thin cover is supplied loose



Inspection buckets for Thin covers with central slot - Slot width 15 mm

GALVANISED

Bucket L mm	Code	Description	Slot height mm	Weight kg	Load class
500	4G02V0	Inspection bucket for galvanised Thin central cover	40	3.97	C 250
	4G02V	Inspection bucket for galvanised Thin central cover	60	4.72	
	4G02V1	Inspection bucket for galvanised Thin central cover	80	5.46	D 400
	4G02V2	Inspection bucket for galvanised Thin central cover	100	6.20	
	4G02V3	Inspection bucket for galvanised Thin central cover	120	6.94	

N.B.: the Thin bucket is supplied loose

AISI 304 STAINLESS STEEL

Bucket L mm	Code	Description	Slot height mm	Weight kg	Load class
500	4G03V0	Inspection bucket for Thin central cover made of AISI 304 stainless steel	40	3.97	C 250
	4G03V	Inspection bucket for Thin central cover made of AISI 304 stainless steel	60	4.72	
	4G03V1	Inspection bucket for Thin central cover made of AISI 304 stainless steel	80	5.46	D 400
	4G03V2	Inspection bucket for Thin central cover made of AISI 304 stainless steel	100	6.20	
	4G03V3	Inspection bucket for Thin central cover made of AISI 304 stainless steel	120	6.94	

N.B.: the Thin bucket is supplied loose

ABS CHANNELS PLASTIC FLY 100 WITH THIN COVER

(for channels with ABS, galvanised and stainless steel edge rail)

SIDE SLOT

ABS channel with ABS, galvanised and stainless steel edge rails complying with the UNI EN 1433 standard. The channels are sold exclusively in complete pallets and together with the gratings.



Plastic Fly 100 channel dimensions

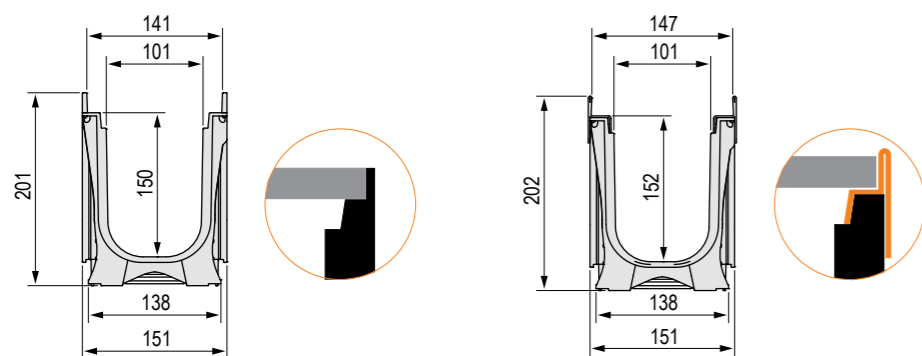

With **ABS** protective edge rail

With protective edge rail **MADE OF GALVANISED STEEL OR AISI 304 STAINLESS STEEL**

Available Thin covers

N.B.: available on request with 10 mm heelguard slot and in AISI 316 stainless steel

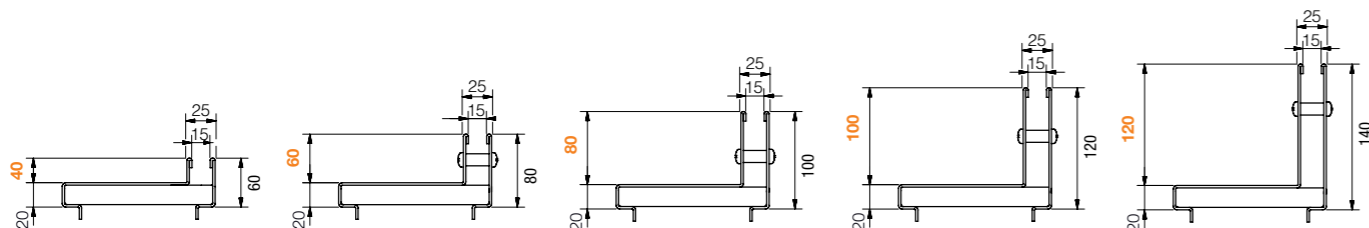

Plastic Fly 100 channel without grating - Length 1,000

Channel L mm	Code	Description	Water passage mm	Run-off section cm ²	Weight kg	Pieces pallet
1,000	4D01S	Plastic Fly 100 ABS channel with ABS protective edge rail	100	142	2.46	loose
	4D02S	Plastic Fly 100 ABS channel with galvanised protective edge rail	100	142	5.03	loose
	4D03S	Plastic Fly 100 ABS channel with AISI 304 stainless steel edge rail	100	142	5.03	loose



Thin covers with side slot - Slot width 15 mm

GALVANISED

Cover L mm	Code	Description	Slot height mm	Weight kg	Load class
1,000	4G02L0	Thin side cover, hot-dip galvanised, Th. 20/10	40	5.28	C 250
	4G02L	Thin side cover, hot-dip galvanised, Th. 20/10	60	5.91	
	4G02L1	Thin side cover, hot-dip galvanised, Th. 20/10	80	6.54	D 400
	4G02L2	Thin side cover, hot-dip galvanised, Th. 20/10	100	7.17	
	4G02L3	Thin side cover, hot-dip galvanised, Th. 20/10	120	7.29	
500	4G05L0	Thin side cover, hot-dip galvanised, Th. 20/10	40	2.63	C 250
	4G05L	Thin side cover, hot-dip galvanised, Th. 20/10	60	2.95	
	4G05L1	Thin side cover, hot-dip galvanised, Th. 20/10	80	3.27	D 400
	4G05L2	Thin side cover, hot-dip galvanised, Th. 20/10	100	3.58	
	4G05L3	Thin side cover, hot-dip galvanised, Th. 20/10	120	3.90	

N.B.: the Thin cover is supplied loose

AISI 304 STAINLESS STEEL

Cover L mm	Code	Description	Slot height mm	Weight kg	Load class
1,000	4G03IL0	Thin side cover made of AISI 304 stainless steel Th. 20/10	40	5.28	C 250
	4G03IL	Thin side cover made of AISI 304 stainless steel Th. 20/10	60	5.91	
	4G03IL1	Thin side cover made of AISI 304 stainless steel Th. 20/10	80	6.54	D 400
	4G03IL2	Thin side cover made of AISI 304 stainless steel Th. 20/10	100	7.17	
	4G03IL3	Thin side cover made of AISI 304 stainless steel Th. 20/10	120	7.29	
500	4G05IL0	Thin side cover made of AISI 304 stainless steel Th. 20/10	40	2.63	C 250
	4G05IL	Thin side cover made of AISI 304 stainless steel Th. 20/10	60	2.95	
	4G05IL1	Thin side cover made of AISI 304 stainless steel Th. 20/10	80	3.27	D 400
	4G05IL2	Thin side cover made of AISI 304 stainless steel Th. 20/10	100	3.58	
	4G05IL3	Thin side cover made of AISI 304 stainless steel Th. 20/10	120	3.90	

N.B.: the Thin cover is supplied loose



Inspection buckets for Thin covers with side slot - Slot width 15 mm

GALVANISED

Bucket L mm	Code	Description	Slot height mm	Weight kg	Load class
500	4G02VL0	Inspection bucket for galvanised Thin side cover	40	3.97	C 250
	4G02VL	Inspection bucket for galvanised Thin side cover	60	4.72	
	4G02VL1	Inspection bucket for galvanised Thin side cover	80	5.46	D 400
	4G02VL2	Inspection bucket for galvanised Thin side cover	100	6.20	
	4G02VL3	Inspection bucket for galvanised Thin side cover	120	6.94	

N.B.: the Thin bucket is supplied loose

AISI 304 STAINLESS STEEL

Bucket L mm	Code	Description	Slot height mm	Weight kg	Load class
500	4G05VL10	Inspection bucket for Thin side cover made of AISI 304 stainless steel	40	3.97	C 250
	4G05VLI	Inspection bucket for Thin side cover made of AISI 304 stainless steel	60	4.72	
	4G05VL11	Inspection bucket for Thin side cover made of AISI 304 stainless steel	80	5.46	D 400
	4G05VL12	Inspection bucket for Thin side cover made of AISI 304 stainless steel	100	6.20	
	4G05VL13	Inspection bucket for Thin side cover made of AISI 304 stainless steel	120	6.94	

N.B.: the Thin bucket is supplied loose

ABS CHANNELS PLASTIC FLY 100 Low

Grating width 150 mm

ABS channel available in various versions for housing the grating: without edge rails, with ABS edge rails or with metal edge rails, complying with the UNI EN 1433 standard. The channels are sold exclusively in complete pallets and together with the gratings.



Dimensions of the Plastic Fly 100 Low channel based on the type of edge rail used

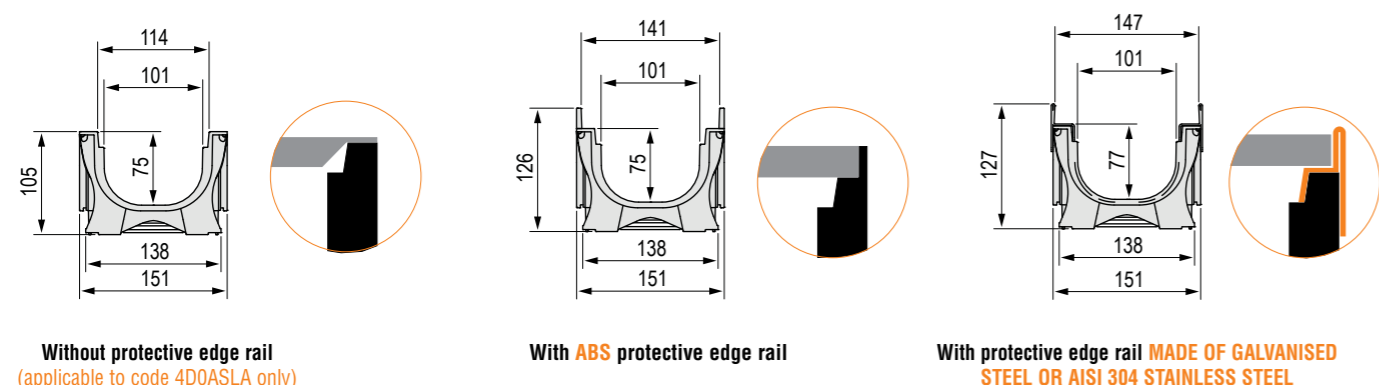

Available gratings

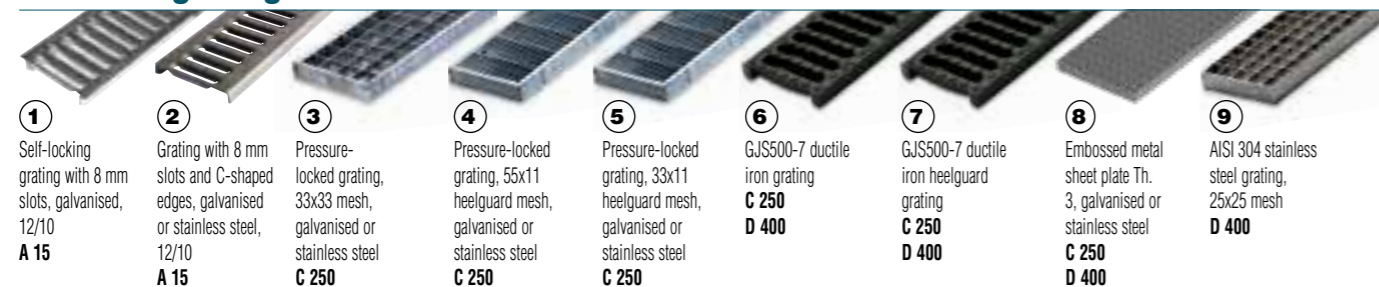

Plastic Fly 100 Low channel complete with grating - Length 1,000 mm

WITHOUT PROTECTIVE EDGE RAIL

Channel L mm	Code	Grating	Description of the channel assembled with the grating complete with accessories	Weight kg	Load class
1,000	4D0ASLA	①	Channel complete with self-locking press-formed metal sheet inlay grating 12/10, galvanised	3.58	A 15

WITH ABS PROTECTIVE EDGE RAIL

Channel L mm	Code	Grating	Description of the channel assembled with the grating complete with accessories	Weight kg	Load class
1,000	4D0BSLC	②	Channel complete with galvanised press-formed metal sheet grating 12/10 with C-shaped edges	3.58	A 15
	4D0BSG1	③	Channel complete with pressure-locked grating with C-shaped edges, 20x2-10x2 33x33, hot-dip galvanised	4.30	
	4D0BSG2	④	Channel complete with pressure-locked grating with C-shaped edges, 20x2-10x2 55x11 heelguard mesh, hot-dip galvanised	5.02	C 250
	4D0BSG3	⑤	Channel complete with pressure-locked grating with C-shaped edges, 20x2-10x2 33x11 heelguard mesh, hot-dip galvanised	5.58	
	4D0BSGS	⑥	Channel complete with 2 x GJS500-7 ductile iron gratings	9.66	
	4D0BSGSA	⑦	Channel complete with 2 x GJS500-7 ductile iron heelguard gratings	11.72	
4D0BSP	⑧	Channel complete with embossed metal sheet solid plate Th. 3, reinforced and hot-dip galvanised	12.01		

WITH GALVANISED PROTECTIVE EDGE RAIL

Channel L mm	Code	Grating	Description of the channel assembled with the grating complete with accessories	Weight kg	Load class
1,000	4D0CSLC	②	Channel complete with galvanised press-formed metal sheet grating 12/10 with C-shaped edges	6.24	A 15
	4D0CSG1	③	Channel complete with pressure-locked grating with C-shaped edges, 20x2-10x2 33x33, hot-dip galvanised	6.96	
	4D0CSG2	④	Channel complete with pressure-locked grating with C-shaped edges, 20x2-10x2 55x11 heelguard mesh, hot-dip galvanised	7.66	C 250
	4D0CSG3	⑤	Channel complete with pressure-locked grating with C-shaped edges, 20x2-10x2 33x11 heelguard mesh, hot-dip galvanised	8.23	
	4D0CSGS	⑥	Channel complete with 2 x GJS500-7 ductile iron gratings	12.32	D 400
	4D0CSGSA	⑦	Channel complete with 2 x GJS500-7 ductile iron heelguard gratings	14.38	
	4D0CSP	⑧	Channel complete with embossed metal sheet solid plate Th. 3, reinforced and hot-dip galvanised	14.67	

WITH AISI 304 STAINLESS STEEL PROTECTIVE EDGE RAIL

Channel L mm	Code	Grating	Description of the channel assembled with the grating complete with accessories	Weight kg	Load class
1,000	4D0DSLCL	②	Channel complete with AISI 304 stainless steel press-formed metal sheet grating 12/10 with C-shaped edges	6.3	A 15
	4D0DSX1	③	Channel complete with pressure-locked grating with edging, 20x2-10x2 33x33, AISI 304 stainless steel	7.97	
	4D0DSX2	④	Channel complete with pressure-locked grating with edging, 20x2-10x2 55x11 heelguard mesh, AISI 304 stainless steel	8.22	C 250
	4D0DSX3	⑤	Channel complete with pressure-locked grating with edging, 20x2-10x2 33x11 heelguard mesh, AISI 304 stainless steel	8.02	
	4D0DSP1	⑧	Channel complete with embossed metal sheet solid plate Th. 3, AISI 304 stainless steel, reinforced	14.67	D 400
	4D0DSX4	⑨	Channel complete with pressure-locked grating with edging, 20x3-10x2 25x25, AISI 304 stainless steel	8.78	

Plastic Fly 100 Low channel accessories

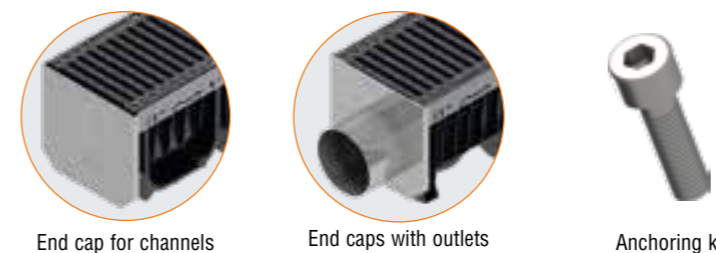

Code	Description	Weight kg
4D0ATI	End cap made of AISI 304 stainless steel sheet Th. 15/10 for Plastic Fly 100 Low channel without edge rail	0.20
4D0BTI	End cap made of AISI 304 stainless steel sheet Th. 15/10 for Plastic Fly 100 Low channel with edge rail	0.32
4D0ARI	End cap with outlet made of AISI 304 stainless steel sheet Th. 15/10 for Plastic Fly 100 Low channel without edge rail, Ø60 mm	0.48
4D0BRI	End cap with outlet made of AISI 304 stainless steel sheet thickness 15/10 for Plastic Fly 100 Low channel with edge rail, Ø89 mm	0.48
4D00K	Anchoring kit for galvanised gratings	0.02
4D00V	Anchoring kit for stainless steel and ductile iron gratings, and for galvanised and stainless steel plates	0.02

Plastic Fly 100 Low channel without grating - Length 1,000 mm

Channel L mm	Code	Description	Water passage mm	Run-off section cm ²	Weight kg	Pieces pallet
1,000	4D0AS	Plastic Fly 100 Low ABS channel	100	69	1.6	78
	4D0BS	Plastic Fly 100 Low ABS channel with ABS protective edge rail	100	69	1.76	78
	4D0CS	Plastic Fly 100 Low ABS channel with galvanised protective edge rail	100	69	4.42	78
	4D0DS	Plastic Fly 100 Low ABS channel with AISI 304 stainless steel edge rail	100	69	4.42	78

ABS CHANNELS PLASTIC FLY 100 Low WITH THIN COVER

(for channels with ABS, galvanised and stainless steel edge rail)

CENTRAL SLOT

ABS channel with ABS, galvanised and stainless steel edge rails complying with the UNI EN 1433 standard. The channels are sold exclusively in complete pallets and together with the gratings.



Plastic Fly 100 Low channel dimensions

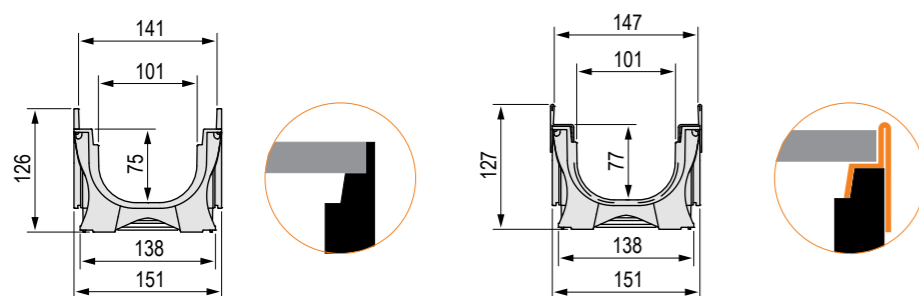

With ABS protective edge rail

With protective edge rail **MADE OF GALVANISED STEEL OR AISI 304 STAINLESS STEEL**

Available Thin covers

N.B.: available on request with 10 mm heelguard slot and in AISI 316 stainless steel

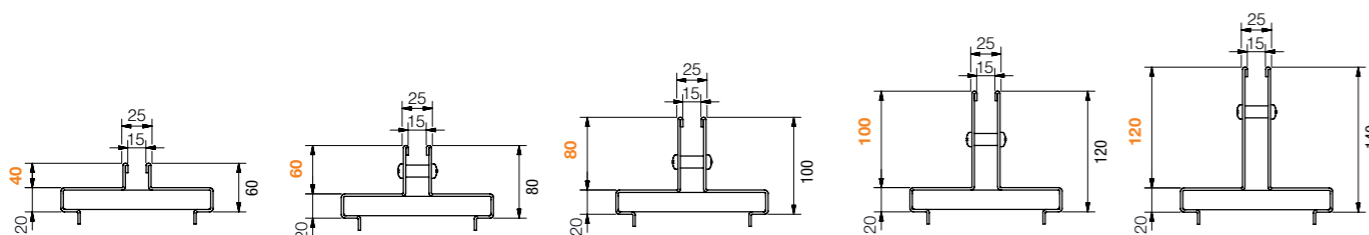

Plastic Fly 100 Low channel without grating - Length 1,000

Channel L mm	Code	Description	Water passage mm	Run-off section cm ²	Weight kg	Pieces pallet
1,000	4D0BS	Plastic Fly 100 Low ABS channel with ABS protective edge rail	100	69	1.76	loose
	4D0CS	Plastic Fly 100 Low ABS channel with galvanised protective edge rail	100	69	4.42	loose
	4D0DS	Plastic Fly 100 Low ABS channel with AISI 304 stainless steel edge rail	100	69	4.42	loose



Thin covers with central slot - Slot width 15 mm

GALVANISED

Cover L mm	Code	Description	Slot height mm	Weight kg	Load class
1,000	4G02T0	Thin central cover, hot-dip galvanised, Th. 20/10	40	5.28	C 250
	4G02T	Thin central cover, hot-dip galvanised, Th. 20/10	60	5.91	
	4G02T1	Thin central cover, hot-dip galvanised, Th. 20/10	80	6.54	D 400
	4G02T2	Thin central cover, hot-dip galvanised, Th. 20/10	100	7.17	
	4G02T3	Thin central cover, hot-dip galvanised, Th. 20/10	120	7.29	
500	4G05T0	Thin central cover, hot-dip galvanised, Th. 20/10	40	2.63	C 250
	4G05T	Thin central cover, hot-dip galvanised, Th. 20/10	60	2.95	
	4G05T1	Thin central cover, hot-dip galvanised, Th. 20/10	80	3.27	D 400
	4G05T2	Thin central cover, hot-dip galvanised, Th. 20/10	100	3.58	
	4G05T3	Thin central cover, hot-dip galvanised, Th. 20/10	120	3.90	

N.B.: the Thin cover is supplied loose

AISI 304 STAINLESS STEEL

Cover L mm	Code	Description	Slot height mm	Weight kg	Load class
1,000	4G03I0	Thin central cover made of AISI 304 stainless steel Th. 20/10	40	5.28	C 250
	4G03I	Thin central cover made of AISI 304 stainless steel Th. 20/10	60	5.91	
	4G03I1	Thin central cover made of AISI 304 stainless steel Th. 20/10	80	6.54	D 400
	4G03I2	Thin central cover made of AISI 304 stainless steel Th. 20/10	100	7.17	
	4G03I3	Thin central cover made of AISI 304 stainless steel Th. 20/10	120	7.29	
500	4G05I0	Thin central cover made of AISI 304 stainless steel Th. 20/10	40	2.63	C 250
	4G05I	Thin central cover made of AISI 304 stainless steel Th. 20/10	60	2.95	
	4G05I1	Thin central cover made of AISI 304 stainless steel Th. 20/10	80	3.27	D 400
	4G05I2	Thin central cover made of AISI 304 stainless steel Th. 20/10	100	3.58	
	4G05I3	Thin central cover made of AISI 304 stainless steel Th. 20/10	120	3.90	

N.B.: the Thin cover is supplied loose



Inspection buckets for Thin covers with central slot - Slot width 15 mm

GALVANISED

Bucket L mm	Code	Description	Slot height mm	Weight kg	Load class
500	4G02V0	Inspection bucket for galvanised Thin central cover	40	3.97	C 250
	4G02V	Inspection bucket for galvanised Thin central cover	60	4.72	
	4G02V1	Inspection bucket for galvanised Thin central cover	80	5.46	D 400
	4G02V2	Inspection bucket for galvanised Thin central cover	100	6.20	
	4G02V3	Inspection bucket for galvanised Thin central cover	120	6.94	

N.B.: the Thin bucket is supplied loose

AISI 304 STAINLESS STEEL

Bucket L mm	Code	Description	Slot height mm	Weight kg	Load class
500	4G03V0	Inspection bucket for Thin central cover made of AISI 304 stainless steel	40	3.97	C 250
	4G03V	Inspection bucket for Thin central cover made of AISI 304 stainless steel	60	4.72	
	4G03V1	Inspection bucket for Thin central cover made of AISI 304 stainless steel	80	5.46	D 400
	4G03V2	Inspection bucket for Thin central cover made of AISI 304 stainless steel	100	6.20	
	4G03V3	Inspection bucket for Thin central cover made of AISI 304 stainless steel	120	6.94	

N.B.: the Thin bucket is supplied loose

ABS CHANNELS PLASTIC FLY 100 Low WITH THIN COVER

(for channels with ABS, galvanised and stainless steel edge rail)

SIDE SLOT

ABS channel with ABS, galvanised and stainless steel edge rails complying with the UNI EN 1433 standard. The channels are sold exclusively in complete pallets and together with the gratings.



Plastic Fly 100 Low channel dimensions

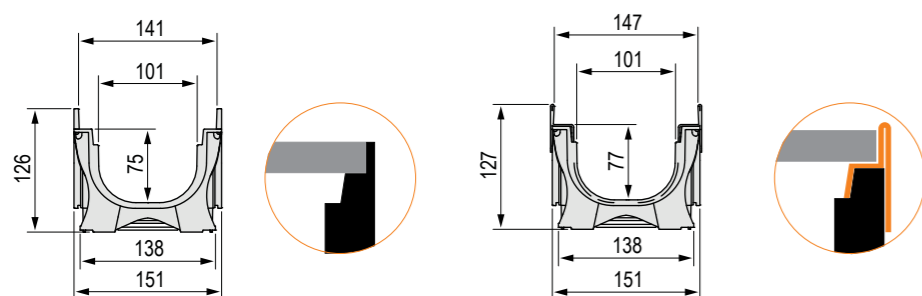

With **ABS** protective edge rail

With protective edge rail **MADE OF GALVANISED STEEL OR AISI 304 STAINLESS STEEL**

Available Thin covers

N.B.: available on request with 10 mm heelguard slot and in AISI 316 stainless steel

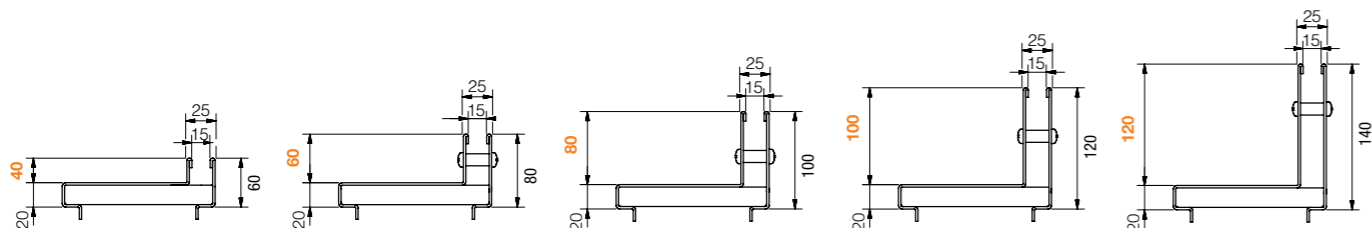

Plastic Fly 100 Low channel without grating - Length 1,000

Channel L mm	Code	Description	Water passage mm	Run-off section cm ²	Weight kg	Pieces pallet
1,000	4D0BS	Plastic Fly 100 Low ABS channel with ABS protective edge rail	100	69	2.46	loose
	4D0CS	Plastic Fly 100 Low ABS channel with galvanised protective edge rail	100	69	5.03	loose
	4D0DS	Plastic Fly 100 Low ABS channel with AISI 304 stainless steel edge rail	100	69	5.03	loose



Thin covers with side slot - Slot width 15 mm

GALVANISED

Cover L mm	Code	Description	Slot height mm	Weight kg	Load class
1,000	4G02L0	Thin side cover, hot-dip galvanised, Th. 20/10	40	5.28	C 250
	4G02L	Thin side cover, hot-dip galvanised, Th. 20/10	60	5.91	
	4G02L1	Thin side cover, hot-dip galvanised, Th. 20/10	80	6.54	D 400
	4G02L2	Thin side cover, hot-dip galvanised, Th. 20/10	100	7.17	
	4G02L3	Thin side cover, hot-dip galvanised, Th. 20/10	120	7.29	
500	4G05L0	Thin side cover, hot-dip galvanised, Th. 20/10	40	2.63	C 250
	4G05L	Thin side cover, hot-dip galvanised, Th. 20/10	60	2.95	
	4G05L1	Thin side cover, hot-dip galvanised, Th. 20/10	80	3.27	D 400
	4G05L2	Thin side cover, hot-dip galvanised, Th. 20/10	100	3.58	
	4G05L3	Thin side cover, hot-dip galvanised, Th. 20/10	120	3.90	

N.B.: the Thin cover is supplied loose

AISI 304 STAINLESS STEEL

Cover L mm	Code	Description	Slot height mm	Weight kg	Load class
1,000	4G03L0	Thin side cover made of AISI 304 stainless steel Th. 20/10	40	5.28	C 250
	4G03L	Thin side cover made of AISI 304 stainless steel Th. 20/10	60	5.91	
	4G03L1	Thin side cover made of AISI 304 stainless steel Th. 20/10	80	6.54	D 400
	4G03L2	Thin side cover made of AISI 304 stainless steel Th. 20/10	100	7.17	
	4G03L3	Thin side cover made of AISI 304 stainless steel Th. 20/10	120	7.29	
500	4G05L0	Thin side cover made of AISI 304 stainless steel Th. 20/10	40	2.63	C 250
	4G05L	Thin side cover made of AISI 304 stainless steel Th. 20/10	60	2.95	
	4G05L1	Thin side cover made of AISI 304 stainless steel Th. 20/10	80	3.27	D 400
	4G05L2	Thin side cover made of AISI 304 stainless steel Th. 20/10	100	3.58	
	4G05L3	Thin side cover made of AISI 304 stainless steel Th. 20/10	120	3.90	

N.B.: the Thin cover is supplied loose



Inspection buckets for Thin covers with side slot - Slot width 15 mm

GALVANISED

Bucket L mm	Code	Description	Slot height mm	Weight kg	Load class
500	4G02VL0	Inspection bucket for galvanised Thin side cover	40	3.97	C 250
	4G02VL	Inspection bucket for galvanised Thin side cover	60	4.72	
	4G02VL1	Inspection bucket for galvanised Thin side cover	80	5.46	D 400
	4G02VL2	Inspection bucket for galvanised Thin side cover	100	6.20	
	4G02VL3	Inspection bucket for galvanised Thin side cover	120	6.94	

N.B.: the Thin bucket is supplied loose

AISI 304 STAINLESS STEEL

Bucket L mm	Code	Description	Slot height mm	Weight kg	Load class
500	4G05VL0	Inspection bucket for Thin side cover made of AISI 304 stainless steel	40	3.97	C 250
	4G05VLI	Inspection bucket for Thin side cover made of AISI 304 stainless steel	60	4.72	
	4G05VL1	Inspection bucket for Thin side cover made of AISI 304 stainless steel	80	5.46	D 400
	4G05VL2	Inspection bucket for Thin side cover made of AISI 304 stainless steel	100	6.20	
	4G05VL3	Inspection bucket for Thin side cover made of AISI 304 stainless steel	120	6.94	

N.B.: the Thin bucket is supplied loose

ABS CHANNELS PLASTIC FLY 150

Grating width 200 mm

ABS channel available in various versions for housing the grating: without edge rails, with ABS edge rails or with metal edge rails, complying with the UNI EN 1433 standard. The channels are sold exclusively in complete pallets and together with the gratings.



Dimensions of the Plastic Fly 150 channel based on the type of edge rail used

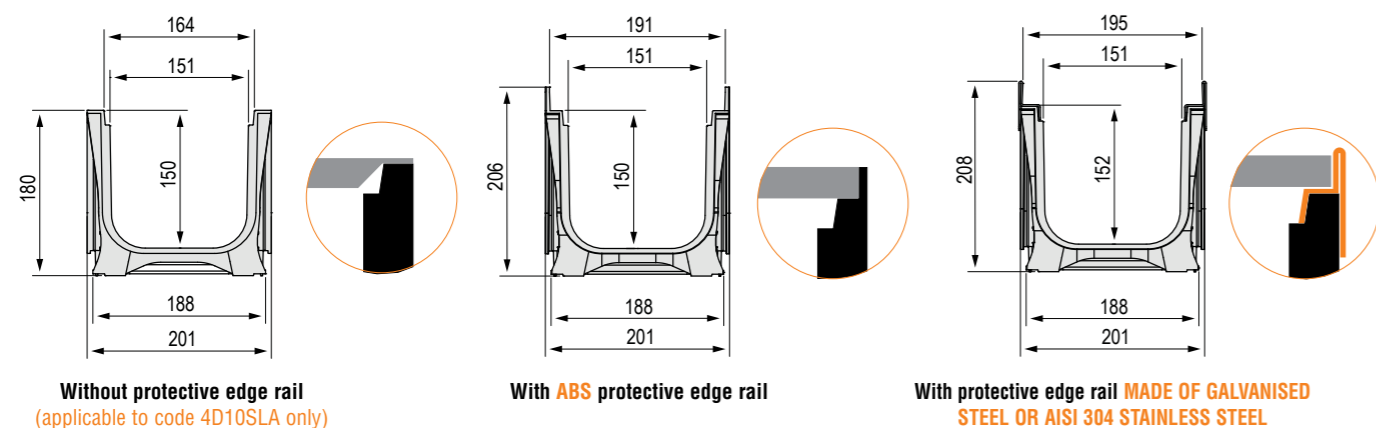

Available gratings

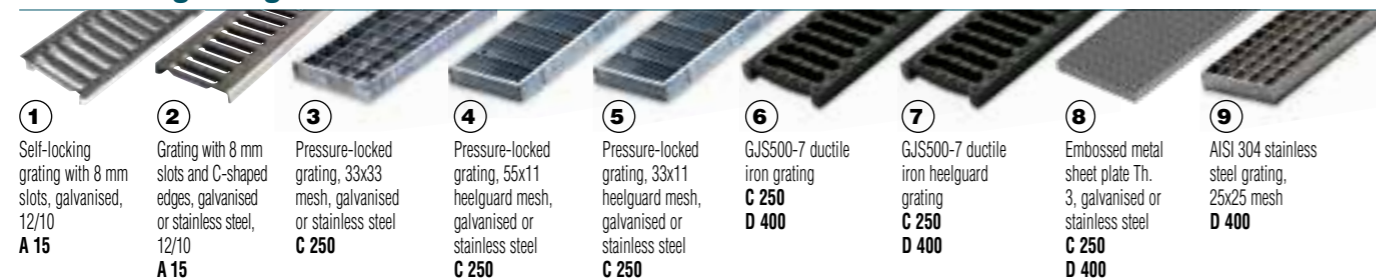

Plastic Fly 150 channel complete with grating - Length 1,000 mm

WITHOUT PROTECTIVE EDGE RAIL

Channel L mm	Code	Grating	Description of the channel assembled with the grating complete with accessories	Weight kg	Load class
1,000	4D10SLA	①	Channel complete with self-locking press-formed metal sheet inlay grating 12/10, galvanised	4.88	A 15

WITH ABS PROTECTIVE EDGE RAIL

Channel L mm	Code	Grating	Description of the channel assembled with the grating complete with accessories	Weight kg	Load class
1,000	4D11SLC	②	Channel complete with galvanised press-formed metal sheet grating 12/10 with C-shaped edges	5.00	A 15
	4D11SG1	③	Channel complete with pressure-locked grating with C-shaped edges, 25x2-10x2 33x33, hot-dip galvanised	6.55	
	4D11SG2	④	Channel complete with pressure-locked grating with C-shaped edges, 25x2-10x2 55x11 heelguard mesh, hot-dip galvanised	7.18	C 250
	4D11SG3	⑤	Channel complete with pressure-locked grating with C-shaped edges, 25x2-10x2 33x11 heelguard mesh, hot-dip galvanised	8.14	
	4D11SGS	⑥	Channel complete with 2 x GJS500-7 ductile iron gratings	18.52	
	4D11SGSA	⑦	Channel complete with 2 x GJS500-7 ductile iron heelguard gratings	20.98	
	4D11SP	⑧	Channel complete with embossed metal sheet solid plate Th. 3, reinforced and hot-dip galvanised	19.39	

WITH GALVANISED PROTECTIVE EDGE RAIL

Channel L mm	Code	Grating	Description of the channel assembled with the grating complete with accessories	Weight kg	Load class
1,000	4D12SLC	②	Channel complete with galvanised press-formed metal sheet grating 12/10 with C-shaped edges	7.64	A 15
	4D12SG1	③	Channel complete with pressure-locked grating with C-shaped edges, 25x2-10x2 33x33, hot-dip galvanised	9.19	
	4D12SG2	④	Channel complete with pressure-locked grating with C-shaped edges, 25x2-10x2 55x11 heelguard mesh, hot-dip galvanised	9.82	C 250
	4D12SG3	⑤	Channel complete with pressure-locked grating with C-shaped edges, 25x2-10x2 33x11 heelguard mesh, hot-dip galvanised	10.78	
	4D12SGS	⑥	Channel complete with 2 x GJS500-7 ductile iron gratings	21.16	
	4D12SGSA	⑦	Channel complete with 2 x GJS500-7 ductile iron heelguard gratings	23.62	D 400
	4D12SP	⑧	Channel complete with embossed metal sheet solid plate Th. 3, reinforced and hot-dip galvanised	22.03	

WITH AISI 304 STAINLESS STEEL PROTECTIVE EDGE RAIL

Channel L mm	Code	Grating	Description of the channel assembled with the grating complete with accessories	Weight kg	Load class
1,000	4D13SLC1	②	Channel complete with AISI 304 stainless steel press-formed metal sheet grating 12/10 with C-shaped edges	7.64	A 15
	4D13SX1	③	Channel complete with pressure-locked grating with edging, 25x2-10x2 33x33, AISI 304 stainless steel	9.46	
	4D13SX2	④	Channel complete with pressure-locked grating with edging, 25x2-10x2 55x11 heelguard mesh, AISI 304 stainless steel	10.06	C 250
	4D13SX3	⑤	Channel complete with pressure-locked grating with edging, 25x2-10x2 33x11 heelguard mesh, AISI 304 stainless steel	10.96	
	4D13SPI	⑧	Channel complete with embossed metal sheet solid plate Th. 3, AISI 304 stainless steel, reinforced	22.03	
	4D13SX4	⑨	Channel complete with pressure-locked grating with edging, 25x3-10x2 25x25, AISI 304 stainless steel	11.86	D 400

Plastic Fly 150 channel accessories



Code	Description	Weight kg
4D10TI	End cap made of AISI 304 stainless steel sheet Th. 15/10 for Plastic Fly 150 channel without edge rail	1.12
4D11TI	End cap made of AISI 304 stainless steel sheet Th. 15/10 for Plastic Fly 150 channel with edge rail	1.18
4D10RI	End cap with outlet made of AISI 304 stainless steel sheet Th. 15/10 for Plastic Fly 150 channel without edge rail, Ø108 mm	1.85
4D11RI	End cap with outlet made of AISI 304 stainless steel sheet thickness 15/10 for Plastic Fly 150 channel with edge rail, Ø147 mm	1.93
4D10K	Anchoring kit for galvanised gratings	0.02
4D10V	Anchoring kit for stainless steel and ductile iron gratings, and for galvanised and stainless steel plates	0.02

Plastic Fly 150 channel without grating - Length 1,000 mm

Channel L mm	Code	Description	Water passage mm	Run-off section cm ²	Weight kg	Pieces pallet
1,000	4D10S	Plastic Fly 150 ABS channel	150	216	2.44	35
	4D11S	Plastic Fly 150 ABS channel with ABS protective edge rail	150	216	2.62	35
	4D12S	Plastic Fly 150 ABS channel with galvanised protective edge rail	150	216	5.26	35
	4D13S	Plastic Fly 150 ABS channel with AISI 304 stainless steel edge rail	150	216	5.26	35

ABS CHANNELS PLASTIC FLY 150 Low

Grating width 200 mm

ABS channel available in various versions for housing the grating: without edge rails, with ABS edge rails or with metal edge rails, complying with the UNI EN 1433 standard. The channels are sold exclusively in complete pallets and together with the gratings.



Dimensions of the Plastic Fly 150 Low channel based on the type of edge rail used

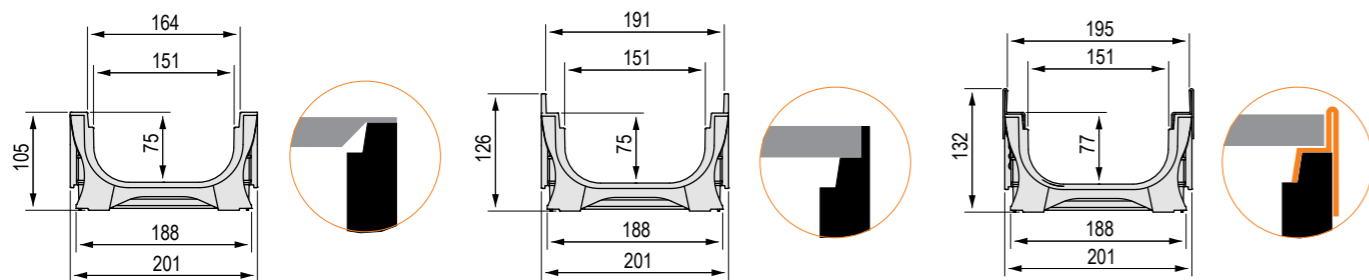

Without protective edge rail
(applicable to code 4D1ASLA only)

With ABS protective edge rail

With protective edge rail **MADE OF GALVANISED STEEL OR AISI 304 STAINLESS STEEL**

Available gratings

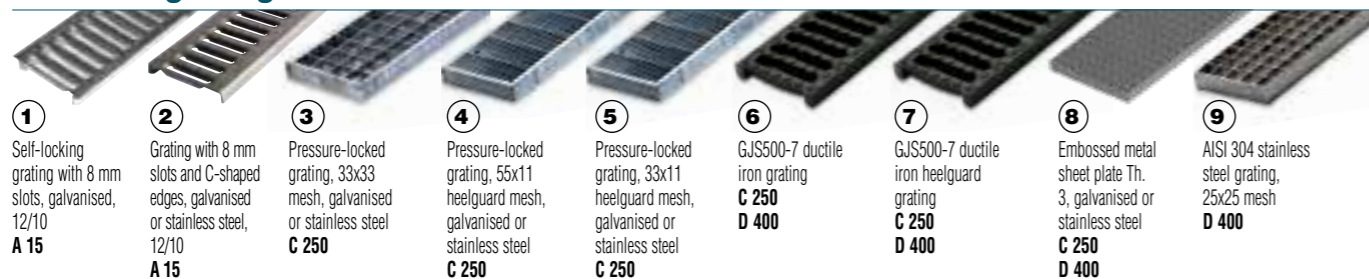

Plastic Fly 150 Low channel complete with grating - Length 1,000 mm

WITHOUT PROTECTIVE EDGE RAIL

Channel L mm	Code	Grating	Description of the channel assembled with the grating complete with accessories	Weight kg	Load class
1,000	4D1ASLA	①	Channel complete with self-locking press-formed metal sheet inlay grating 12/10, galvanised	4.21	A 15

WITH ABS PROTECTIVE EDGE RAIL

Channel L mm	Code	Grating	Description of the channel assembled with the grating complete with accessories	Weight kg	Load class
1,000	4D1BSLC	②	Channel complete with galvanised press-formed metal sheet grating 12/10 with C-shaped edges	4.31	C 250
	4D1BSG1	③	Channel complete with pressure-locked grating with C-shaped edges, 25x2-10x2 33x33, hot-dip galvanised	5.86	
	4D1BSG2	④	Channel complete with pressure-locked grating with C-shaped edges, 25x2-10x2 55x11 heelguard mesh, hot-dip galvanised	6.49	
	4D1BSG3	⑤	Channel complete with pressure-locked grating with C-shaped edges, 25x2-10x2 33x11 heelguard mesh, hot-dip galvanised	7.45	
	4D1BSGS	⑥	Channel complete with 2 x GJS500-7 ductile iron gratings	17.83	
	4D1BSGSA	⑦	Channel complete with 2 x GJS500-7 ductile iron heelguard gratings	20.29	
	4D1BSP	⑧	Channel complete with embossed metal sheet solid plate Th. 3, reinforced and hot-dip galvanised	18.7	

WITH GALVANISED PROTECTIVE EDGE RAIL

Channel L mm	Code	Grating	Description of the channel assembled with the grating complete with accessories	Weight kg	Load class
1,000	4D1CSLC	②	Channel complete with galvanised press-formed metal sheet grating 12/10 with C-shaped edges	6.97	A 15
	4D1CSG1	③	Channel complete with pressure-locked grating with C-shaped edges, 25x2-10x2 33x33, hot-dip galvanised	8.52	
	4D1CSG2	④	Channel complete with pressure-locked grating with C-shaped edges, 25x2-10x2 55x11 heelguard mesh, hot-dip galvanised	9.15	C 250
	4D1CSG3	⑤	Channel complete with pressure-locked grating with C-shaped edges, 25x2-10x2 33x11 heelguard mesh, hot-dip galvanised	10.11	
	4D1CSGS	⑥	Channel complete with 2 x GJS500-7 ductile iron gratings	20.49	D 400
	4D1CSGSA	⑦	Channel complete with 2 x GJS500-7 ductile iron heelguard gratings	22.95	
	4D1CSP	⑧	Channel complete with embossed metal sheet solid plate Th. 3, AISI 304 stainless steel, reinforced	21.36	

WITH AISI 304 STAINLESS STEEL PROTECTIVE EDGE RAIL

Channel L mm	Code	Grating	Description of the channel assembled with the grating complete with accessories	Weight kg	Load class
1,000	4D1DSLCL	②	Channel complete with AISI 304 stainless steel press-formed metal sheet grating 12/10 with C-shaped edges	6.97	A 15
	4D1DSX1	③	Channel complete with pressure-locked grating with edging, 25x2-10x2 33x33, AISI 304 stainless steel	8.79	
	4D1DSX2	④	Channel complete with pressure-locked grating with edging, 25x2-10x2 55x11 heelguard mesh, AISI 304 stainless steel	9.39	C 250
	4D1DSX3	⑤	Channel complete with pressure-locked grating with edging, 25x2-10x2 33x11 heelguard mesh, AISI 304 stainless steel	10.29	
	4D1DSP1	⑧	Channel complete with embossed metal sheet solid plate Th. 3, AISI 304 stainless steel, reinforced	21.36	D 400
	4D1DSX4	⑨	Channel complete with pressure-locked grating with edging, 25x3-10x2 25x25, AISI 304 stainless steel	21.36	

Plastic Fly 150 Low channel accessories

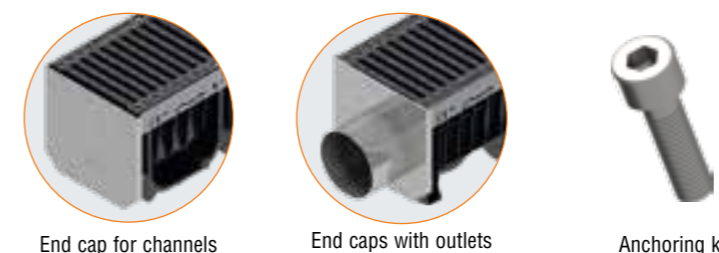

Code	Description	Weight kg
4D1ATI	End cap made of AISI 304 stainless steel sheet Th. 15/10 for Plastic Fly 150 Low channel without edge rail	1.08
4D1BTI	End cap made of AISI 304 stainless steel sheet Th. 15/10 for Plastic Fly 150 Low channel with edge rail	1.15
4D1ARI	End cap with outlet made of AISI 304 stainless steel sheet Th. 15/10 for Plastic Fly 150 Low channel without edge rail, Ø60 mm	1.74
4D1BRI	End cap with outlet made of AISI 304 stainless steel sheet thickness 15/10 for Plastic Fly 150 Low channel with edge rail, Ø89 mm	1.83
4D10K	Anchoring kit for galvanised gratings	0.02
4D10V	Anchoring kit for stainless steel and ductile iron gratings, and for galvanised and stainless steel plates	0.02

Plastic Fly 150 Low channel without grating - Length 1,000 mm

Channel L mm	Code	Description	Water passage mm	Run-off section cm ²	Weight kg	Pieces pallet
1,000	4D1AS	Plastic Fly 150 Low ABS channel	150	106	1.77	55
	4D1BS	Plastic Fly 150 Low ABS channel with ABS protective edge rail	150	106	1.93	55
	4D1CS	Plastic Fly 150 Low ABS channel with galvanised protective edge rail	150	106	4.59	55
	4D1DS	Plastic Fly 150 Low ABS channel with AISI 304 stainless steel edge rail	150	106	4.59	55

ABS CHANNELS PLASTIC FLY 200

Grating width 250 mm

ABS channel available in various versions for housing the grating: without edge rails, with ABS edge rails or with metal edge rails, complying with the UNI EN 1433 standard. The channels are sold exclusively in complete pallets and together with the gratings.



Dimensions of the Plastic Fly 200 channel based on the type of edge rail used

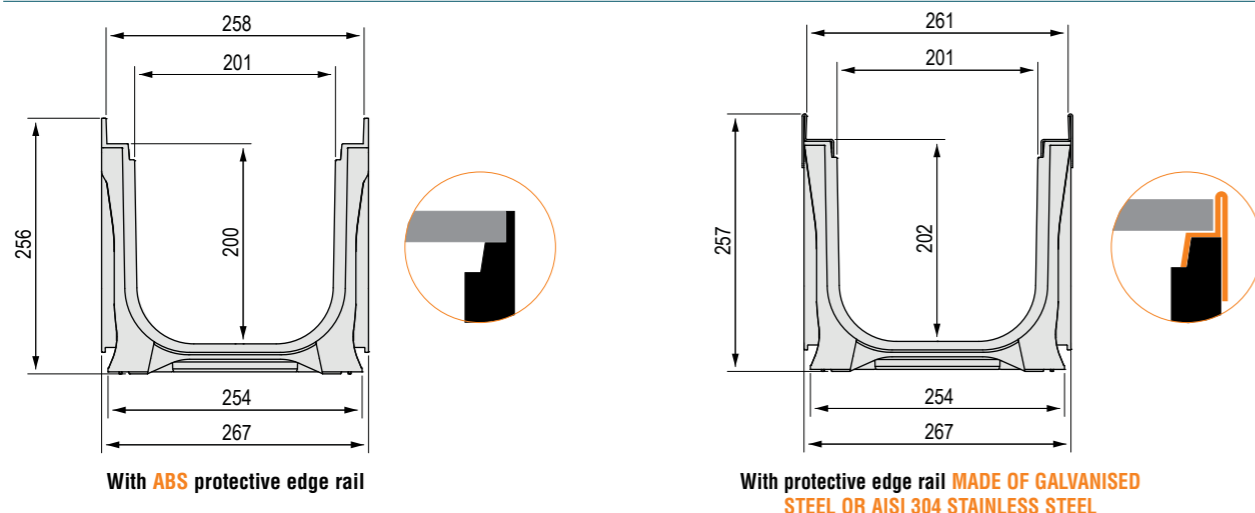

Available gratings

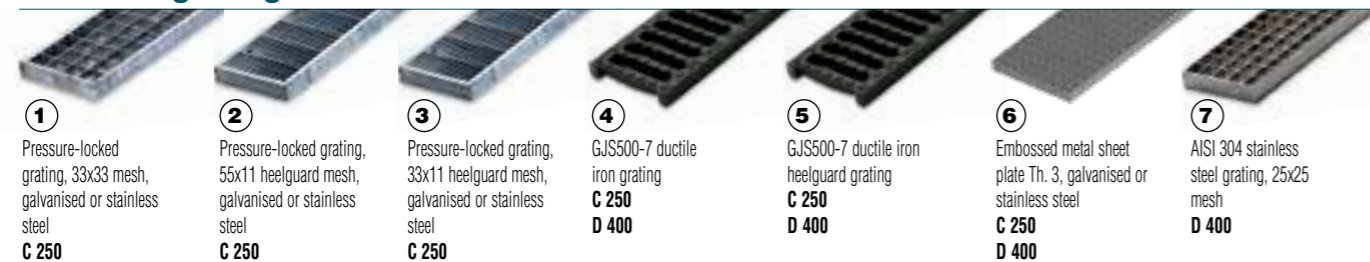

Plastic Fly 200 channel complete with grating - Length 1,000 mm

WITH ABS PROTECTIVE EDGE RAIL

Channel L mm	Code	Grating	Description of the channel assembled with the grating complete with accessories	Weight kg	Load class
1,000	4D21SG1	①	Channel complete with pressure-locked grating with C-shaped edges, 25x2-10x2 33x33, hot-dip galvanised	10.12	C 250
	4D21SG2	②	Channel complete with pressure-locked grating with C-shaped edges, 25x2-10x2 55x11 heelguard mesh, hot-dip galvanised	11.05	
	4D21SG3	③	Channel complete with pressure-locked grating with C-shaped edges, 25x2-10x2 33x11 heelguard mesh, hot-dip galvanised	12.34	
	4D21SGS	④	Channel complete with 2 x GJS500-7 ductile iron gratings	27.86	
	4D21SGSA	⑤	Channel complete with 2 x GJS500-7 ductile iron heelguard gratings	29.74	
	4D21SP	⑥	Channel complete with embossed metal sheet solid plate Th. 3, reinforced and hot-dip galvanised	29.53	

WITH GALVANISED PROTECTIVE EDGE RAIL

Channel L mm	Code	Grating	Description of the channel assembled with the grating complete with accessories	Weight kg	Load class
1,000	4D22SG1	①	Channel complete with pressure-locked grating with C-shaped edges, 25x2-10x2 33x33, hot-dip galvanised	12.75	C 250
	4D22SG2	②	Channel complete with pressure-locked grating with C-shaped edges, 25x2-10x2 55x11 heelguard mesh, hot-dip galvanised	13.68	
	4D22SG3	③	Channel complete with pressure-locked grating with C-shaped edges, 25x2-10x2 33x11 heelguard mesh, hot-dip galvanised	14.97	
	4D22SGS	④	Channel complete with GJS500-7 ductile iron gratings	30.49	D 400
	4D22SGSA	⑤	Channel complete with GJS500-7 ductile iron heelguard gratings	32.37	
	4D22SP	⑥	Channel complete with embossed metal sheet solid plate Th. 3, reinforced and hot-dip galvanised	32.16	

WITH AISI 304 STAINLESS STEEL PROTECTIVE EDGE RAIL

Channel L mm	Code	Grating	Description of the channel assembled with the grating complete with accessories	Weight kg	Load class
1,000	4D23SX1	①	Channel complete with pressure-locked grating with edging, 25x2-10x2 33x33, AISI 304 stainless steel	12.99	C 250
	4D23SX2	②	Channel complete with pressure-locked grating with edging, 25x2-10x2 55x11 heelguard mesh, AISI 304 stainless steel	13.79	
	4D23SX3	③	Channel complete with pressure-locked grating with edging, 25x2-10x2 33x11 heelguard mesh, AISI 304 stainless steel	14.99	
	4D23SPI	⑥	Channel complete with embossed metal sheet solid plate Th. 3, AISI 304 stainless steel, reinforced	33.32	D 400
	4D23SX4	⑦	Channel complete with pressure-locked grating with edging, 25x3-10x2 25x25, AISI 304 stainless steel	16.19	

Plastic Fly 200 channel accessories



Code	Description	Weight kg
4D21TI	End cap made of AISI 304 stainless steel sheet Th. 15/10 for Plastic Fly 200 channel with edge rail	1.08
4D21RI	End cap with outlet made of AISI 304 stainless steel sheet thickness 15/10 for Plastic Fly 200 channel with edge rail, Ø168 mm	2.15
4D20K	Anchoring kit for galvanised gratings	0.02
4D20V	Anchoring kit for stainless steel and ductile iron gratings, and for galvanised and stainless steel plates	0.02

Plastic Fly 200 channel without grating - Length 1,000 mm

Channel L mm	Code	Description	Water passage mm	Run-off section cm ²	Weight kg	Pieces pallet
1,000	4D21S	Plastic Fly 200 ABS channel with ABS protective edge rail	200	381	5.02	24
	4D22S	Plastic Fly 200 ABS channel with galvanised protective edge rail	200	381	7.65	24
	4D23S	Plastic Fly 200 ABS channel with AISI 304 stainless steel edge rail	200	381	7.69	24

ABS CHANNELS PLASTIC FLY 200 Low

Grating width 250 mm

ABS channel available in various versions for housing the grating: without edge rails, with ABS edge rails or with metal edge rails, complying with the UNI EN 1433 standard. The channels are sold exclusively in complete pallets and together with the gratings.



Dimensions of the Plastic Fly 200 Low channel based on the type of edge rail used

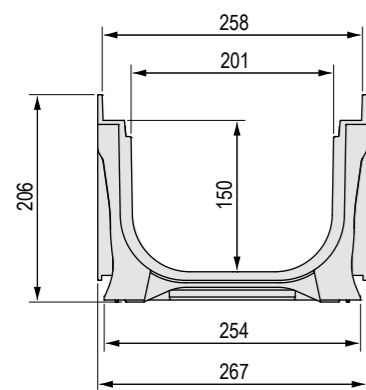

With ABS protective edge rail

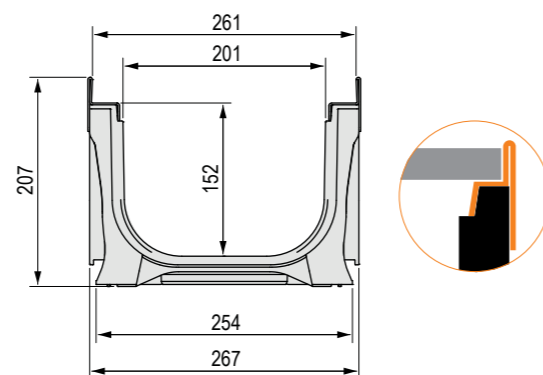

With protective edge rail MADE OF GALVANISED STEEL OR STAINLESS STEEL

Available gratings

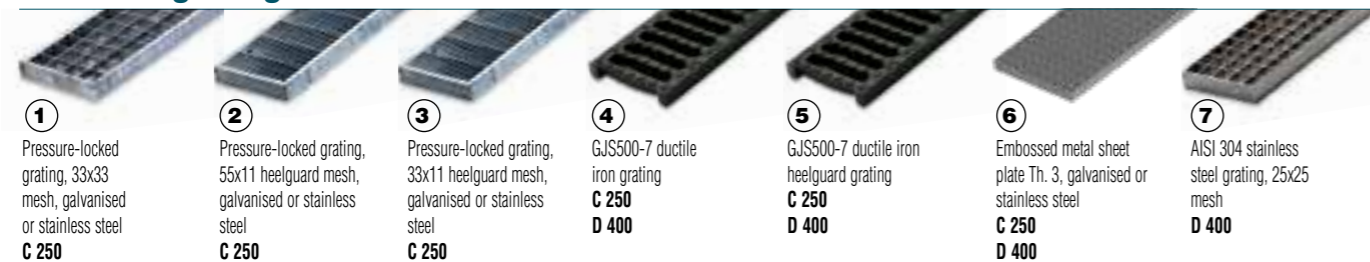

Plastic Fly 200 Low channel complete with grating - Length 1,000 mm

WITH ABS PROTECTIVE EDGE RAIL

Channel L mm	Code	Grating	Description of the channel assembled with the grating complete with accessories	Weight kg	Load class
1,000	4D2BSG1	①	Channel complete with pressure-locked grating with C-shaped edges, 25x2-10x2 33x33, hot-dip galvanised	8.77	C 250
	4D2BSG2	②	Channel complete with pressure-locked grating with C-shaped edges, 25x2-10x2 55x11 heelguard mesh, hot-dip galvanised	9.70	
	4D2BSG3	③	Channel complete with pressure-locked grating with C-shaped edges, 25x2-10x2 33x11 heelguard mesh, hot-dip galvanised	10.99	
	4D2BSGS	④	Channel complete with 2 x GJS500-7 ductile iron gratings	26.51	
	4D2BSGSA	⑤	Channel complete with 2 x GJS500-7 ductile iron heelguard gratings	28.39	
	4D2BSP	⑥	Channel complete with embossed metal sheet solid plate Th. 3, reinforced and hot-dip galvanised	28.18	

WITH GALVANISED PROTECTIVE EDGE RAIL

Channel L mm	Code	Grating	Description of the channel assembled with the grating complete with accessories	Weight kg	Load class
1,000	4D2CSG1	①	Channel complete with pressure-locked grating with C-shaped edges, 25x2-10x2 33x33, hot-dip galvanised	11.43	C 250
	4D2CSG2	②	Channel complete with pressure-locked grating with C-shaped edges, 25x2-10x2 55x11 heelguard mesh, hot-dip galvanised	12.63	
	4D2CSG3	③	Channel complete with pressure-locked grating with C-shaped edges, 25x2-10x2 33x11 heelguard mesh, hot-dip galvanised	13.65	
	4D2CSGS	④	Channel complete with 2 x GJS500-7 ductile iron gratings	29.17	D 400
	4D2CSGSA	⑤	Channel complete with 2 x GJS500-7 ductile iron heelguard gratings	31.06	
	4D2CSP	⑥	Channel complete with embossed metal sheet solid plate Th. 3, reinforced and hot-dip galvanised	30.84	

WITH AISI 304 STAINLESS STEEL PROTECTIVE EDGE RAIL

Channel L mm	Code	Grating	Description of the channel assembled with the grating complete with accessories	Weight kg	Load class
1,000	4D2DSX1	①	Channel complete with pressure-locked grating with edging, 25x2-10x2 33x33, AISI 304 stainless steel	11.63	C 250
	4D2DSX2	②	Channel complete with pressure-locked grating with edging, 25x2-10x2 55x11 heelguard mesh, AISI 304 stainless steel	12.43	
	4D2DSX3	③	Channel complete with pressure-locked grating with edging, 25x2-10x2 33x11 heelguard mesh, AISI 304 stainless steel	13.63	
	4D2DSP1	⑥	Channel complete with embossed metal sheet solid plate Th. 3, AISI 304 stainless steel, reinforced	30.84	D 400
	4D2DSX4	⑦	Channel complete with pressure-locked grating with edging, 25x3-10x2 25x25, AISI 304 stainless steel	14.83	

Plastic Fly 200 Low channel accessories

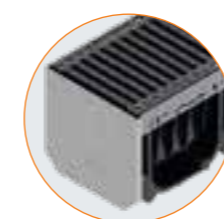

End cap for channels



End caps with outlets



Anchoring kit

Code	Description	Weight kg
4D2BTI	End cap made of AISI 304 stainless steel sheet Th. 15/10 for Plastic Fly 200 Low channel with edge rail	1.08
4D2BRI	End cap with outlet made of AISI 304 stainless steel sheet thickness 15/10 for Plastic Fly 200 Low channel with edge rail, Ø147 mm	1.74
4D20K	Anchoring kit for galvanised gratings	0.02
4D20V	Anchoring kit for stainless steel and ductile iron gratings, and for galvanised and stainless steel plates	0.02

Plastic Fly 200 Low channel without grating - Length 1,000 mm

Channel L mm	Code	Description	Water passage mm	Run-off section cm ²	Weight kg	Pieces pallet
1,000	4D2BS	Plastic Fly 200 Low ABS channel with ABS protective edge rail	200	283	3.67	32
	4D2CS	Plastic Fly 200 Low ABS channel with galvanised protective edge rail	200	283	6.34	32
	4D2DS	Plastic Fly 200 Low ABS channel with AISI 304 stainless steel edge rail	200	283	6.34	32

GRIDIRON®

ALTERNATIVE DRAINAGE SYSTEMS

PAGE
268

WATERTRAP SUMP UNITS FOR BRIDGES

PAGE
272

**DRAINAGE SYSTEMS FOR ROOF GARDENS
SOFT DRAIN SHEET METAL CHANNELS**

ALTERNATIVE DRAINAGE SYSTEMS

GRIDIRON®
BUILD YOUR CHANGES

ALTERNATIVE DRAINAGE SYSTEMS

SUMP UNITS FOR BRIDGES WATERTRAP

In draining bridges, it is crucial to let the water on the surface run-off as quickly as possible to prevent the aquaplaning effect, which could endanger the safety of drivers.

The Watertrap sump unit was designed in order to recover water running off bridges.

Composed of a Bucket Lith galvanized steel or AISI 304 stainless steel run-off pipe and Class D 400 ductile iron grating secured to the drainage body by steel screws, it is a safe, functional and easy-to-use product.



LOAD CLASSES

In accordance with the UNI EN 124:2015 standard



D 400

ALTERNATIVE DRAINAGE SYSTEMS

WATERTRAP SUMP UNITS FOR BRIDGES

TECHNICAL CHARACTERISTICS

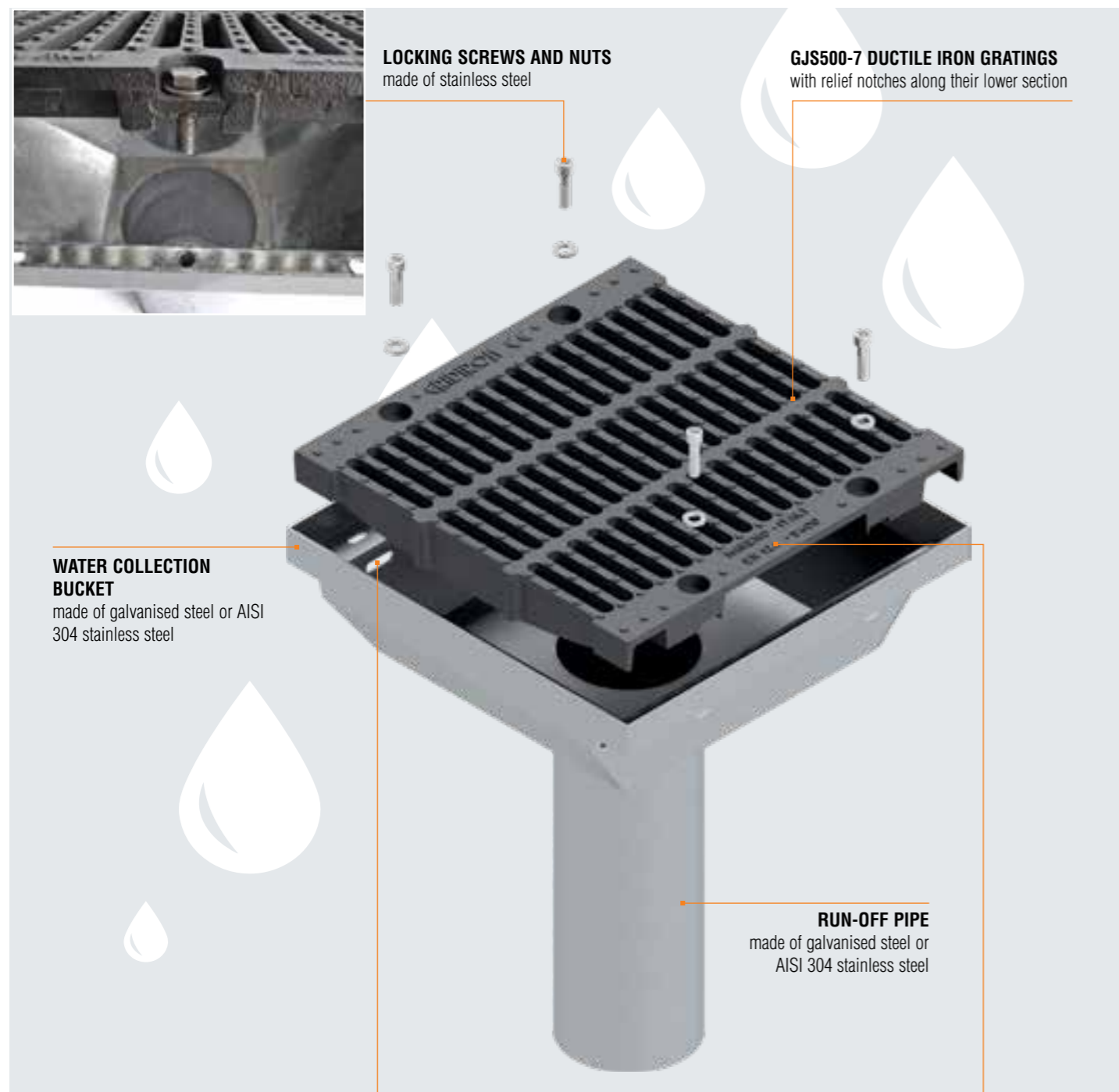

WATER DRAINAGE SLOTS

The sump unit's bucket is slotted on both sides for enhanced water run-off deriving from the use of draining asphalt.



MARKING

The Watertrap model road sump unit is marked according to the provisions of the EN 124:2015 standard

ALTERNATIVE DRAINAGE SYSTEMS

WATERTRAP SUMP UNITS FOR BRIDGES



506 x 510 Watertrap sump units

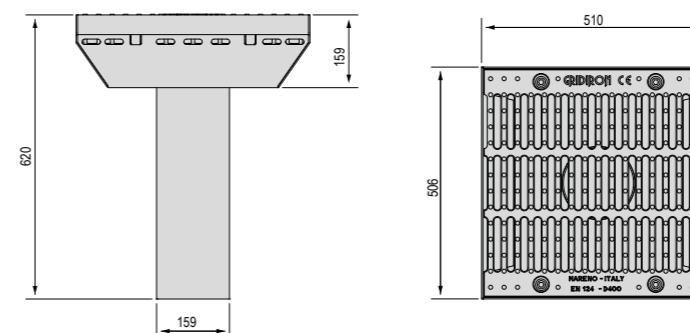

Dimensions mm	Code	Description	Water passage free surface cm ²	Weight kg	Load class
506 x 510	4R10PGS	Galvanised sump unit complete with GJS500-7 ductile iron grating secured to direct vertical trap ø159 mm	826	60.00	D 400

276 x 510 Watertrap sump units

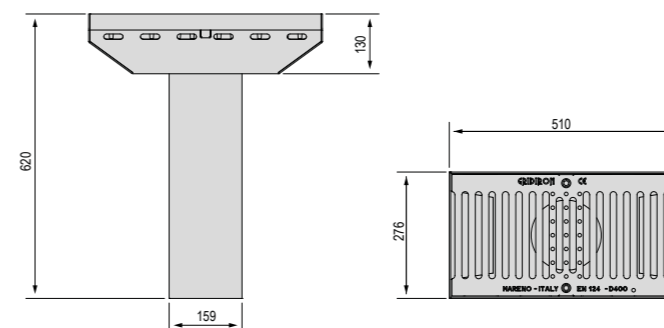

Dimensions mm	Code	Description	Water passage free surface cm ²	Weight kg	Load class
276 x 510	4R03PGS	Galvanised sump unit complete with GJS500-7 ductile iron grating secured to direct vertical trap ø159 mm	451	30.00	D 400
276 x 510	4R03PIGS	Sump unit made of AISI 304 stainless steel complete with GJS500-7 ductile iron grating secured to direct vertical trap ø159 mm	451	30.00	D 400

DRAINAGE SYSTEMS FOR ROOF GARDENS

SOFT DRAIN

SHEET METAL CHANNELS

The Soft Drain channel is designed for draining rainwater from sensitive areas such as roof gardens, through specially designed slots on the walls of the channel itself. The system is equipped with a height adjustment mechanism and can be adapted to the installation needs.

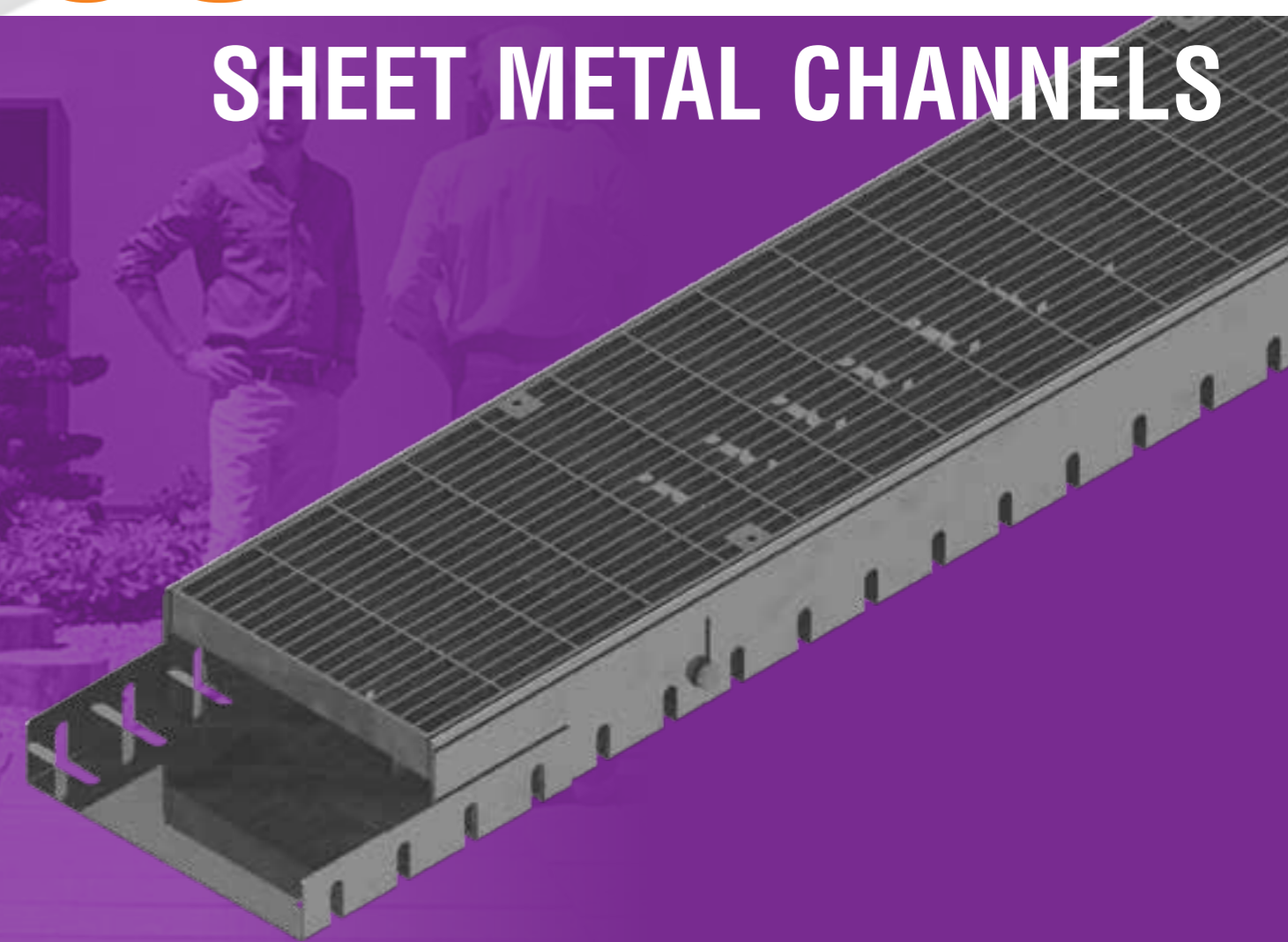

- SOFT DRAIN 100
- SOFT DRAIN 150
- SOFT DRAIN 200

ALTERNATIVE DRAINAGE SYSTEMS

LOAD CLASSES

In accordance with the UNI EN 1433 standard



A 15



SHEET METAL CHANNELS
SOFT DRAIN



SYSTEM AND TECHNICAL CHARACTERISTICS

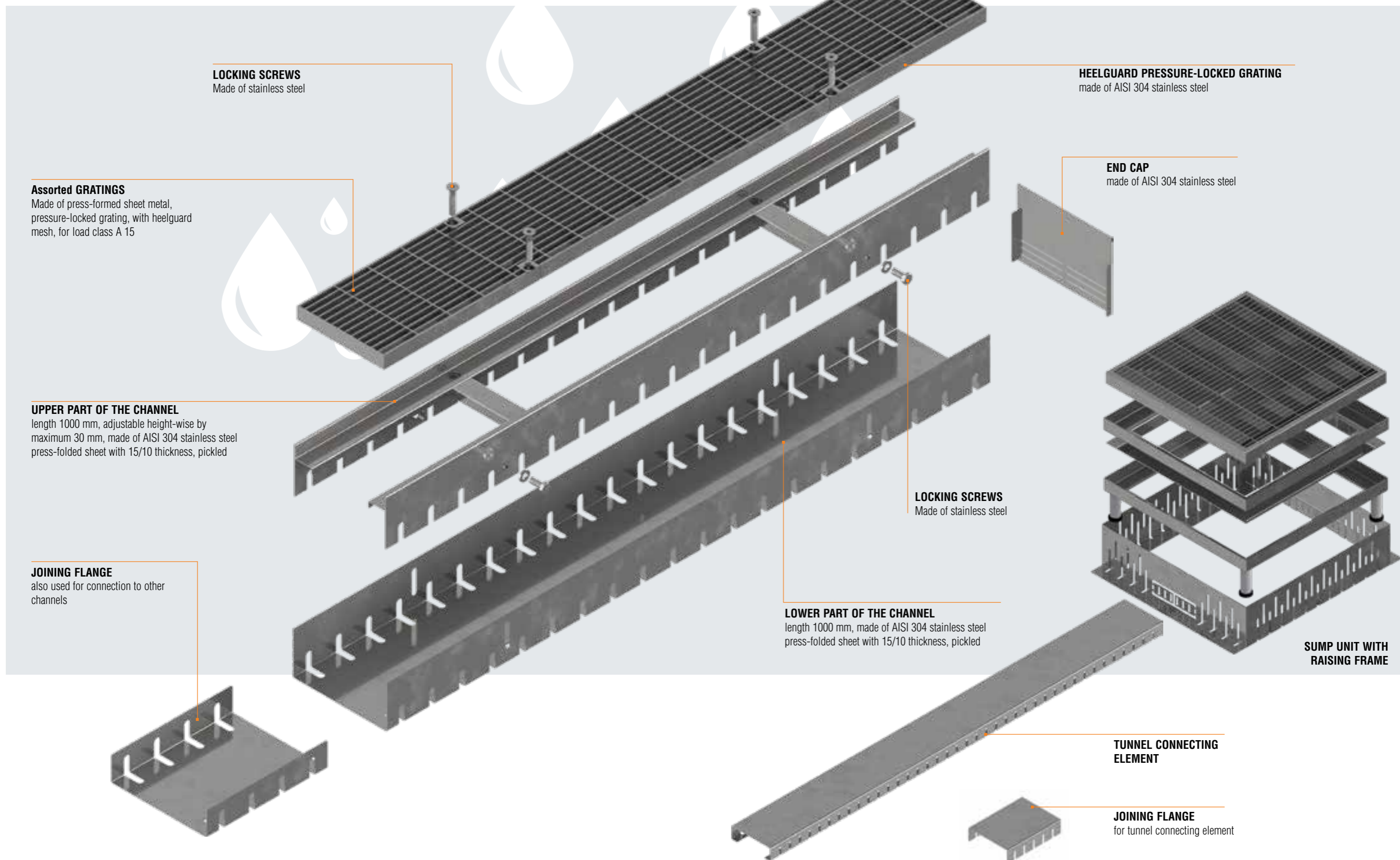

SHEET METAL CHANNELS

SOFT DRAIN 100

Grating width 150 mm

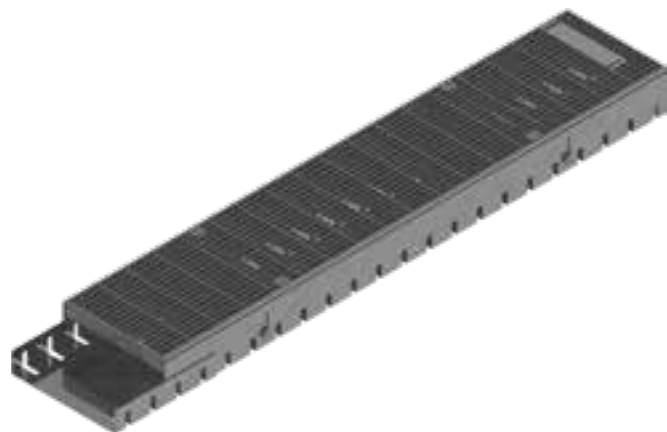

Dimensions of Soft Drain 100 Channel

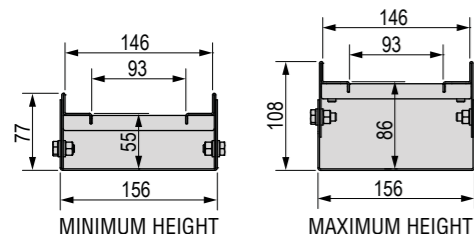

Available gratings

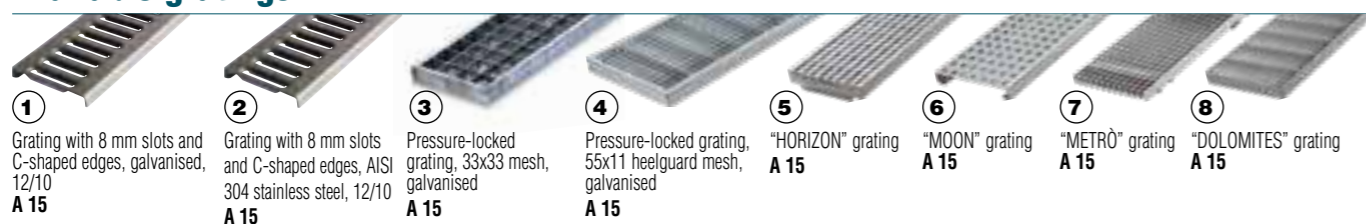

Soft Drain 100 channel with grating - Length 1000 / 500 mm

Channel L mm	Code	Grating	Description of the channel assembled with the grating complete with accessories	Weight kg	Load class
1000	6S00SLC	①	Channel with galvanised press-formed sheet metal grating with 8 mm slots, Th. 12/10, with C-shaped edges, self-locking	8.42	A 15
	6S00SLCI	②	Channel with press-formed AISI 304 stainless steel sheet grating with 8 mm slots, Th. 12/10, with C-shaped edges, self-locking	8.42	
	6S00SG1	③	Channel with pressure-locked grating with C-shaped edges, 20x2-10x2 33x33, hot-dip galvanised	9.14	
	6S00SG2	④	Channel with pressure-locked grating with C-shaped edges, 20x2-10x2 55x11 heelguard mesh, hot-dip galvanised	9.84	
	6S00SD1	⑤	Channel with "HORIZON" model AISI 304 stainless steel grating with U-shaped longitudinal profiles, 6 mm heelguard slots, self-locking	10.17	
	6S00SD2	⑥	Channel with "MOON" model AISI 304 stainless steel sheet grating, Th. 12/10, Ø10 holes, self-locking	9.45	
	6S00SD3	⑦	Channel with "METRÒ" model AISI 304 stainless steel grating, with 15x3 longitudinal plates, self-locking	11.57	
	6S00SD4	⑧	Channel with "DOLOMITES" model AISI 304 stainless steel grating, with triangular-shaped profiles, self-locking	10.26	
500	6S00MSLC	①	Channel with galvanised press-formed sheet metal grating with 8 mm slots, Th. 12/10, with C-shaped edges, self-locking	4.21	A 15
	6S00MSLCI	②	Channel with press-formed AISI 304 stainless steel sheet grating with 8 mm slots, Th. 12/10, with C-shaped edges, self-locking	4.21	
	6S00MSG1	③	Channel with pressure-locked grating with C-shaped edges, 20x2-10x2 33x33, hot-dip galvanised	4.57	
	6S00MSG2	④	Channel with pressure-locked grating with C-shaped edges, 20x2-10x2 55x11 heelguard mesh, hot-dip galvanised	4.92	
	6S00MSD1	⑤	Channel with "HORIZON" model AISI 304 stainless steel grating with U-shaped longitudinal profiles, 6 mm heelguard slots, self-locking	5.09	
	6S00MSD2	⑥	Channel with "MOON" model AISI 304 stainless steel sheet grating, Th. 12/10, Ø10 holes, self-locking	4.73	
	6S00MSD3	⑦	Channel with "METRÒ" model AISI 304 stainless steel grating, with 15x3 longitudinal plates, self-locking	5.79	
	6S00MSD4	⑧	Channel with "DOLOMITES" model AISI 304 stainless steel grating, with triangular-shaped profiles, self-locking	5.13	

Soft Drain 100 sheet metal channel without grating - Length 1000 / 500 mm

Channel L mm	Code	Description	Water passage mm	Runoff section minimum H cm ²	Runoff section maximum H cm ²	Weight kg
1000	6S00S	AISI 304 stainless steel Soft Drain 100 channel	93	80	126	6.60
500	6S00MS	AISI 304 stainless steel Soft Drain 100 channel	93	80	126	3.30

SHEET METAL CHANNELS

SOFT DRAIN 150

Grating width 200 mm



Dimensions of Soft Drain 150 Channel

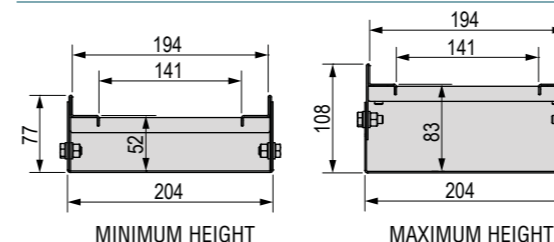

Available gratings



Soft Drain 150 channel with grating - Length 1000 / 500 mm

Channel L mm	Code	Grating	Description of the channel assembled with the grating complete with accessories	Weight kg	Load class
1000	6S05SLC	①	Channel with galvanised press-formed sheet metal grating with 8 mm slots, Th. 12/10, with C-shaped edges, self-locking	9.68	A 15
	6S05SLCI	②	Channel with press-formed AISI 304 stainless steel sheet grating with 8 mm slots, Th. 12/10, with C-shaped edges, self-locking	9.68	
	6S05SG1	③	Channel with pressure-locked grating with C-shaped edges, 25x2-10x2 33x33, hot-dip galvanised	11.23	
	6S05SG2	④	Channel with pressure-locked grating with C-shaped edges, 25x2-10x2 55x11 heelguard mesh, hot-dip galvanised	11.86	
	6S05SD1	⑤	Channel with "HORIZON" model AISI 304 stainless steel grating with U-shaped longitudinal profiles, 6 mm heelguard slots, self-locking	12.11	
	6S05SD2	⑥	Channel with "MOON" model AISI 304 stainless steel sheet grating, Th. 12/10, Ø10 holes, self-locking	11.15	
	6S05SD3	⑦	Channel with "METRÒ" model AISI 304 stainless steel grating, with 15x3 longitudinal plates, self-locking	14.00	
	6S05SD4	⑧	Channel with "DOLOMITES" model AISI 304 stainless steel grating, with triangular-shaped profiles, self-locking	12.24	
500	6S05MSLC	①	Channel with galvanised press-formed sheet metal grating with 8 mm slots, Th. 12/10, with C-shaped edges, self-locking	4.79	A 15
	6S05MSLCI	②	Channel with press-formed AISI 304 stainless steel sheet grating with 8 mm slots, Th. 12/10, with C-shaped edges, self-locking	4.79	
	6S05MSG1	③	Channel with pressure-locked grating with C-shaped edges, 25x2-10x2 33x33, hot-dip galvanised	5.57	
	6S05MSG2	④	Channel with pressure-locked grating with C-shaped edges, 25x2-10x2 55x11 heelguard mesh, hot-dip galvanised	5.88	
	6S05MSD1	⑤	Channel with "HORIZON" model AISI 304 stainless steel grating with U-shaped longitudinal profiles, 6 mm heelguard slots, self-locking	6.01	
	6S05MSD2	⑥	Channel with "MOON" model AISI 304 stainless steel sheet grating, Th. 12/10, Ø10 holes, self-locking	5.53	
	6S05MSD3	⑦	Channel with "METRÒ" model AISI 304 stainless steel grating, with 15x3 longitudinal plates, self-locking	6.95	
	6S05MSD4	⑧	Channel with "DOLOMITES" model AISI 304 stainless steel grating, with triangular-shaped profiles, self-locking	6.07	

Soft Drain 150 sheet metal channel without grating - Length 1000 / 500 mm

Channel L mm	Code	Description	Water passage mm	Runoff section minimum H cm ²	Runoff section maximum H cm ²	Weight kg
1000	6S05S	AISI 304 stainless steel Soft Drain 150 channel	141	104	167	7.30
500	6S05MS	AISI 304 stainless steel Soft Drain 150 channel	141	104	167	3.60

SHEET METAL CHANNELS

SOFT DRAIN 200

Grating width 250 mm



Dimensions of Soft Drain 200 Channel

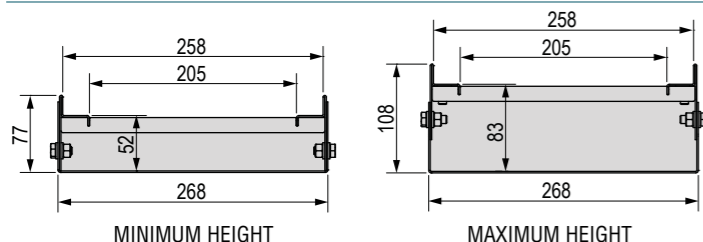

Available gratings

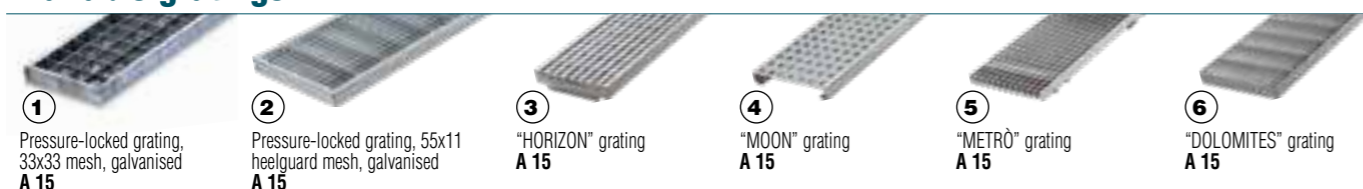

Soft Drain 200 channel with grating - Length 1000 / 500 mm

Channel L mm	Code	Grating	Description of the channel assembled with the grating complete with accessories	Weight kg	Load class
1000	6S10SG1	①	Channel with pressure-locked grating with C-shaped edges, 25x2-10x2 33x33, hot-dip galvanised	13.70	A 15
	6S10SG2	②	Channel with pressure-locked grating with C-shaped edges, 25x2-10x2 55x11 heelguard mesh, hot-dip galvanised	14.63	
	6S10SD1	③	Channel with "HORIZON" model AISI 304 stainless steel grating with U-shaped longitudinal profiles, 6 mm heelguard slots, self-locking	15.04	
	6S10SD2	④	Channel with "MOON" model AISI 304 stainless steel sheet grating, Th. 12/10, Ø10 holes, self-locking	13.74	
	6S10SD3	⑤	Channel with "METRÒ" model AISI 304 stainless steel grating, with 15x3 longitudinal plates, self-locking	17.56	
	6S10SD4	⑥	Channel with "DOLOMITES" model AISI 304 stainless steel grating, with triangular-shaped profiles, self-locking	15.20	
500	6S10MSG1	①	Channel with pressure-locked grating with C-shaped edges, 25x2-10x2 33x33, hot-dip galvanised	6.85	A 15
	6S10MSG2	②	Channel with pressure-locked grating with C-shaped edges, 25x2-10x2 55x11 heelguard mesh, hot-dip galvanised	7.32	
	6S10MSD1	③	Channel with "HORIZON" model AISI 304 stainless steel grating with U-shaped longitudinal profiles, 6 mm heelguard slots, self-locking	7.52	
	6S10MSD2	④	Channel with "MOON" model AISI 304 stainless steel sheet grating, Th. 12/10, Ø10 holes, self-locking	6.87	
	6S10MSD3	⑤	Channel with "METRÒ" model AISI 304 stainless steel grating, with 15x3 longitudinal plates, self-locking	8.78	
	6S10MSD4	⑥	Channel with "DOLOMITES" model AISI 304 stainless steel grating, with triangular-shaped profiles, self-locking	7.60	

Soft Drain 200 sheet metal channel without grating - Length 1000 / 500 mm

Channel L mm	Code	Description	Water passage mm	Runoff section minimum H cm ²	Runoff section maximum H cm ²	Weight kg
1000	6S10S	AISI 304 stainless steel Soft Drain 200 channel	205	138	221	8.60
500	6S10MS	AISI 304 stainless steel Soft Drain 200 channel	205	138	221	4.30

Accessories for Soft Drain 100 - 150 - 200 sheet metal channels

Sump unit-tunnel assembly

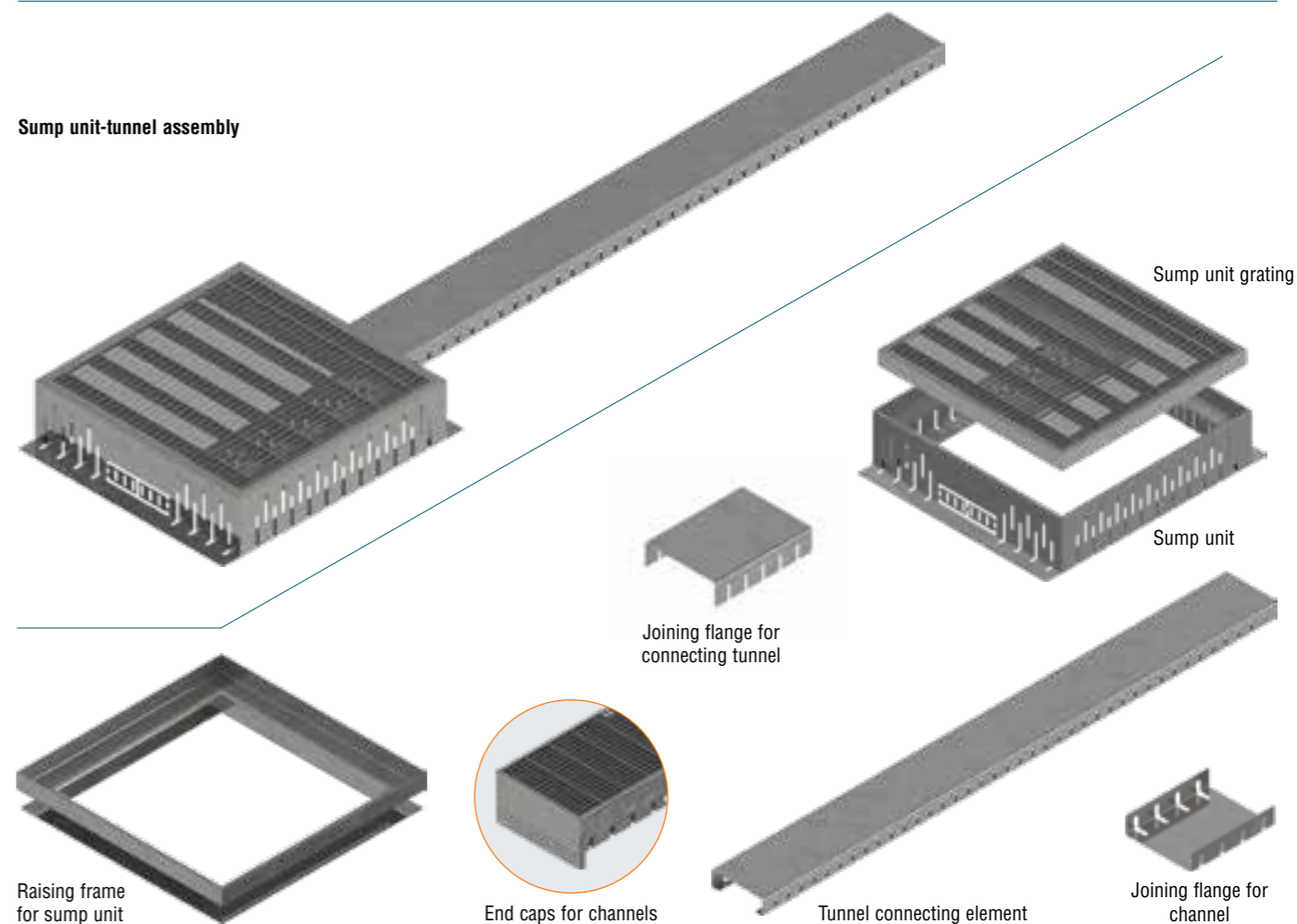

Code	Description	Weight kg
6S30P	Soft Drain 100-150-200 sump unit dimensions 350x350 mm	3.00
6S40P	Soft Drain 100-150-200 sump unit dimensions 450x450 mm	3.80
6S50P	Soft Drain 100-150-200 sump unit dimensions 550x550 mm	4.70
6S33RP	Raising frame for sump unit size 350x350 H 30	2.30
6S36RP	Raising frame for sump unit size 350x350 H 60	3.40
6S312RP	Raising frame for sump unit size 350x350 H 120	4.50
6S43RP	Raising frame for sump unit size 450x450 H 30	2.90
6S46RP	Raising frame for sump unit size 450x450 H 60	4.30
6S412RP	Raising frame for sump unit size 450x450 H 120	3.70
6S53RP	Raising frame for sump unit size 550x550 H 30	3.60
6S56RP	Raising frame for sump unit size 550x550 H 60	5.30
6S512RP	Raising frame for sump unit size 550x550 H 120	4.50
5312G	Pressure-locked grating for Soft Drain sump unit size 350x350 with C-shaped edges, 25x2-10x2 55x11 heelguard mesh, hot-dip galvanised	2.80
5313G	Pressure-locked grating for Soft Drain sump unit size 450x450 with C-shaped edges, 25x2-10x2 55x11 heelguard mesh, hot-dip galvanised	4.70
5314G	Pressure-locked grating for Soft Drain sump unit size 550x550 with C-shaped edges, 25x2-10x2 55x11 heelguard mesh, hot-dip galvanised	7.10
6S00T	End cap for Soft Drain 100 channel	0.21
6S05T	End cap for Soft Drain 150 channel	0.28
6S10T	End cap for Soft Drain 200 channel	0.36
6S00F	Joining flange for Soft Drain 100 channel	0.50
6S05F	Joining flange for Soft Drain 150 channel	0.60
6S10F	Joining flange for Soft Drain 200 channel	0.80
6S00RT	Tunnel connecting element L=1000	2.00
6S00RT2	Tunnel connecting element L=2000	4.00
6S00RTF	Joining flange for connecting tunnel	0.30

GRIDIRON®

ECOLOGICALLY SUSTAINABLE DRAINAGE SYSTEMS

PAGE
286

ENVIRO SERIES CHANNELS

PAGE
288

ENVIRO SERIES DECKS

PAGE
294

ENVIRO SERIES KERBS



GRIDIRON®
BUILD YOUR CHANGES

ECOLOGICALLY SUSTAINABLE
DRAINAGE SYSTEMS

ECOLOGICALLY SUSTAINABLE DRAINAGE SYSTEMS

ENVIRO SERIES

Expressions such as ENVIRONMENTAL SUSTAINABILITY and, SAFEGUARDING OF THE ECOLOGY and TERRITORY are heard with growing frequency, even in work contexts involving recovery and run off of meteoric or induced water. GRIDIRON, a leader in the sector and a company acutely sensitive to the water/ecology problem, has introduced a new ecologically sustainable drainage range: the ENVIRO SERIES.



- ENVIRO CHANNELS
- ENVIRO DECKS
- ENVIRO KERBS
- IT - KERBS

LOAD CLASSES

In accordance with the UNI EN 1433 standard



D 400



ECOLOGICALLY SUSTAINABLE DRAINAGE SYSTEMS

ENVIRO SERIES

SYSTEM AND TECHNICAL CHARACTERISTICS

Enviro channels and kerbs are manufactured with plastic and natural rock crushed into powder. The two components are then combined in the production cycle to create a 100% RECYCLED product, therefore their use guarantees the following ENVIRONMENTAL ADVANTAGES:

ENVIRONMENTAL ADVANTAGES

Concrete/polymer concrete products	Enviro
All raw materials are extracted with the aid of large machinery.	The raw materials were originally created for other products. The production of our units, therefore, does not imply any additional harmful emissions.
The products comprise concrete or resin, all used in the process.	The kerbs and channels are manufactured using furnaces and moulds. This represents the greatest factor of harmful emissions.
Traditional products are handled within the production facility and on-site using stackers with a greater frequency than for the Enviro series.	The products are handled using stackers within production facilities and on-site, but their light weight allows for loading a greater quantity on each stacker.
The TRANSPORT COST is one of the major problems. An articulated lorry can carry 26 tons of raw materials or finished products. Thanks to the light weight of our products, transport costs are substantially lower.	TRANSPORT – We are able to transport 1,320 units per load (660 mts), compared to the 320 units (160 mts) of concrete kerbs that can be transported. This is certainly the major aspect to be taken into account.
Most concrete products must be installed with the aid of machinery due to their excessive weight and, therefore, involve considerable costs related to fuel emissions.	All products of the Enviro range are installed manually. As a result, the cost related to fuel emissions is significantly reduced compared to concrete products.



IMPROVED HYDRAULIC PERFORMANCE

Products of the Enviro Series are constructed with composite material, which guarantees improved hydraulic performance compared to traditional materials.

DESIGN AND HYDRAULIC SYSTEMS

The projects developed by GRIDIRON include the possibility of providing schematic programming and CAD drawings that comprise the preferred product. The proposed solutions range from straightforward diagrams to complex computer-generated drawings.

Diagramme de flux hydraulique de EnviroKerb 125 mm avec pente légère



Diagramme de flux hydraulique de Enviro 125 mm avec pente légère



We design custom-made solutions for specific problems concerning the tender.

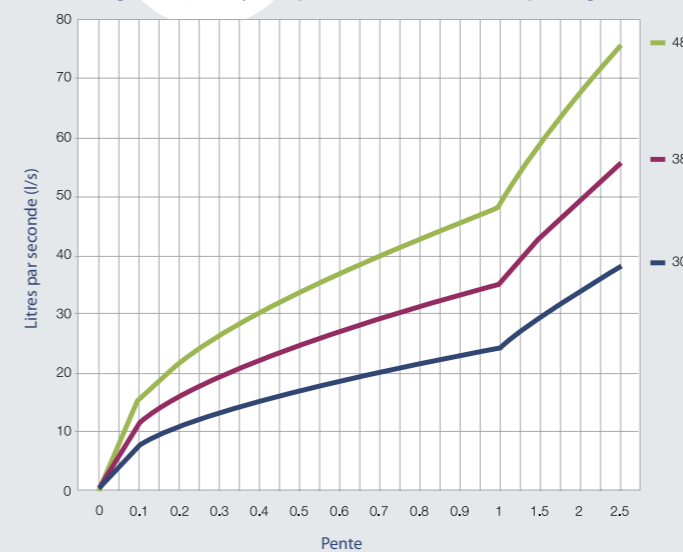
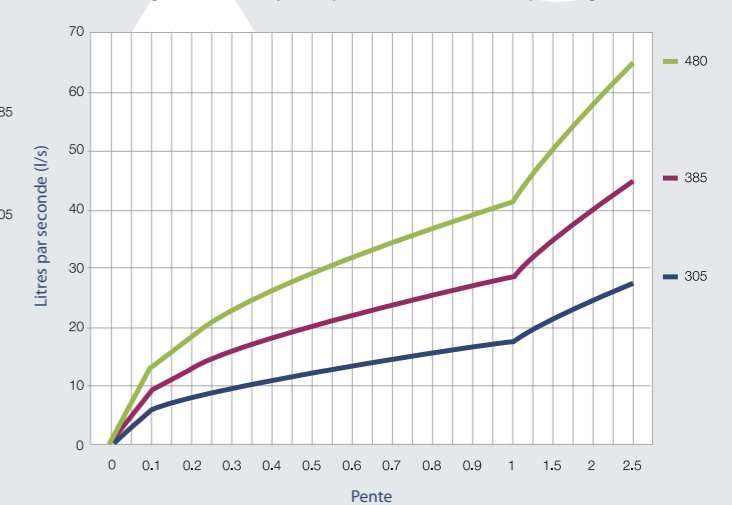
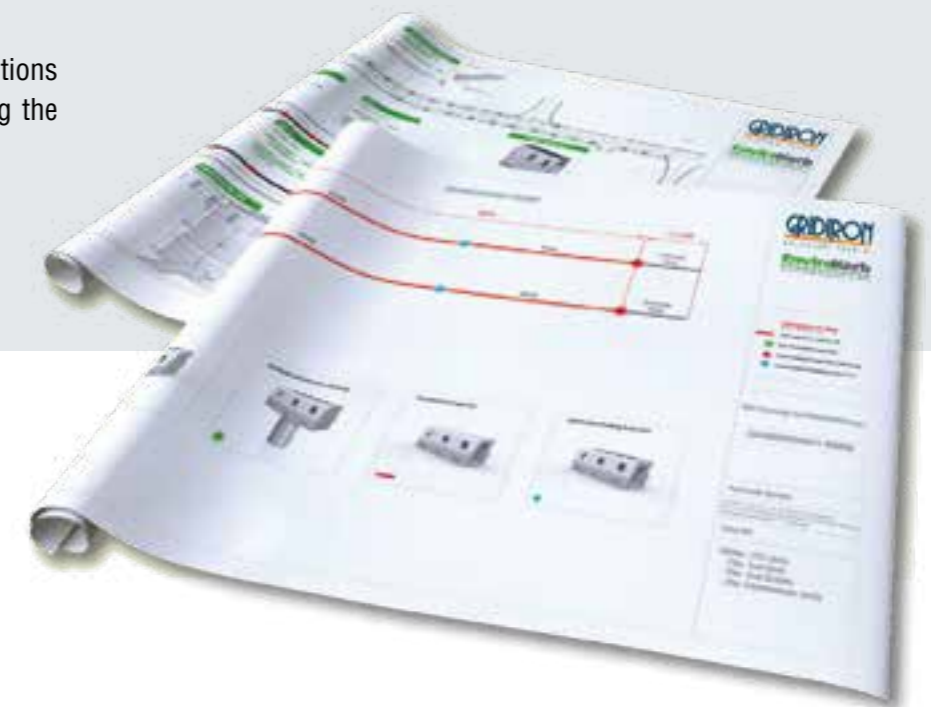

ENVIRO SERIES CHANNELS **Envirochannel**



H 180 H 205 H 260 H 285 H 355 H 380

N.B.: AVAILABLE ALSO WITH 200 mm OPENING

Enviro Channel dimensions

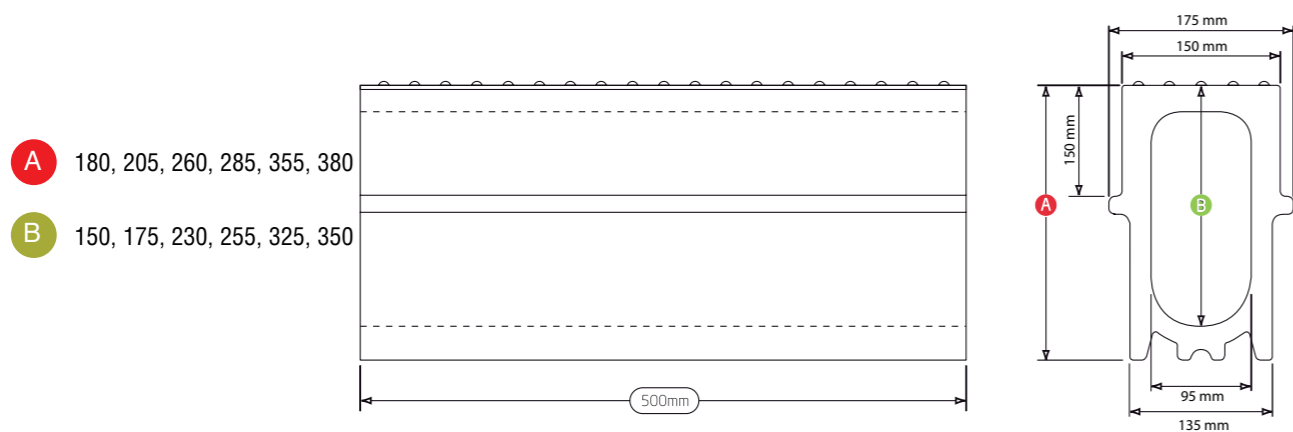

- A** 180, 205, 260, 285, 355, 380
- B** 150, 175, 230, 255, 325, 350

Enviro Channels - length 500 mm

Channel L mm	Code	Description	Water passage mm	Internal height mm	Total height mm	Weight kg	Pieces pallet	Load class
500	4EC1S	Monobloc ENVIRO CHANNEL with 10 mm slots, conforming to UNI EN 1433	95	150	180	11.00	108	D 400
	4EC2S	Monobloc ENVIRO CHANNEL with 10 mm slots, conforming to UNI EN 1433	95	175	205	12.00	96	
	4EC3S	Monobloc ENVIRO CHANNEL with 10 mm slots, conforming to UNI EN 1433	95	230	260	15.50	72	
	4EC4S	Monobloc ENVIRO CHANNEL with 10 mm slots, conforming to UNI EN 1433	95	255	285	16.50	60	
	4EC5S	Monobloc ENVIRO CHANNEL with 10 mm slots, conforming to UNI EN 1433	95	325	355	17.50	48	
	4EC6S	Monobloc ENVIRO CHANNEL with 10 mm slots, conforming to UNI EN 1433	95	350	380	18.50	48	



- 1 INSPECTION UNITS**
Positioned every 20–30 m, the inspection units have a solid cover fixed to the channel with screws.
- 2 SUMP UNIT**
Inspectable sump unit with either front or side drainage that can be positioned at the beginning or the end of the section.

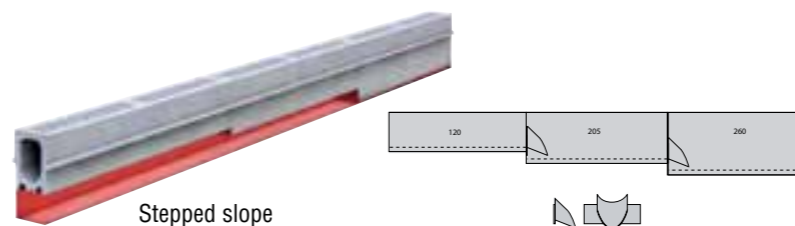
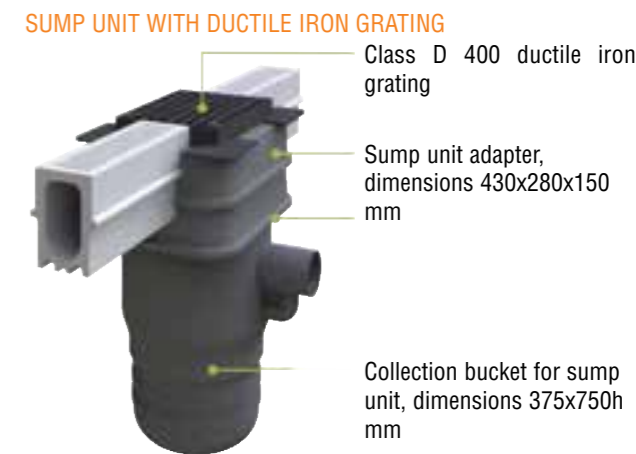

STEPPED SLOPE
Envirochannel offers an extensive range of heights suitable for installation on surfaces with stepped slope. The Envirochannel system is equipped with a chute that enables the water to run off continuously along the various channel heights.

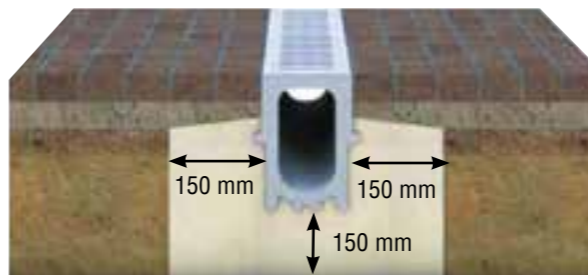

INSTALLATION EXAMPLES
Envirochannel can be incorporated in multiple paving finishes, such as; pave', asphalt or finished concrete. (For specifications, or other installation details, refer to the technical sheets).

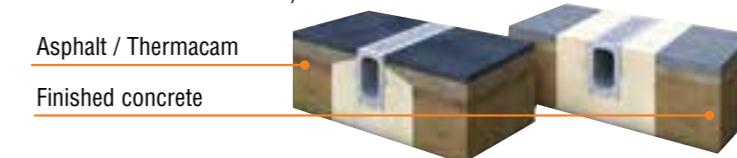

Code	Description	Weight kg
4EC1C	Inspection unit for ENVIRO CHANNEL H 180 with solid cover made of composite resin secured with screws	11.00
4EC2C	Inspection unit for ENVIRO CHANNEL H 205 with solid cover made of composite resin secured with screws	12.00
4EC3C	Inspection unit for ENVIRO CHANNEL H 260 with solid cover made of composite resin secured with screws	15.50
4EC4C	Inspection unit for ENVIRO CHANNEL H 285 with solid cover made of composite resin secured with screws	16.50
4EC5C	Inspection unit for ENVIRO CHANNEL H 355 with solid cover made of composite resin secured with screws	17.50
4EC6C	Inspection unit for ENVIRO CHANNEL H 380 with solid cover made of composite resin secured with screws	18.50
4EC1P	Sump unit for ENVIRO CHANNEL with solid cover made of composite resin secured with screws	34.00
4EC1PG	Inspectable sump unit for ENVIRO CHANNEL with ductile iron grating and adapters that can be adjusted height-wise	44.00
4EC1PP	Sump unit adapter (for code 4EC1PG only)	11.00
4EC1T	End cap for ENVIRO CHANNEL H 180	0.92
4EC2T	End cap for ENVIRO CHANNEL H 205	0.94
4EC3T	End cap for ENVIRO CHANNEL H 260	0.96
4EC4T	End cap for ENVIRO CHANNEL H 285	0.98
4EC5T	End cap for ENVIRO CHANNEL H 355	1.00
4EC6T	End cap for ENVIRO CHANNEL H 380	1.20
4EC1R	End cap with outlet for ENVIRO CHANNEL H 180, diameter 110 mm	1.08
4EC2R	End cap with outlet for ENVIRO CHANNEL H 205, diameter 110 mm	1.10
4EC3R	End cap with outlet for ENVIRO CHANNEL H 260, diameter 110 mm	1.12
4EC4R	End cap with outlet for ENVIRO CHANNEL H 285, diameter 110 mm	1.14
4EC5R	End cap with outlet for ENVIRO CHANNEL H 355, diameter 110 mm	1.16
4EC6R	End cap with outlet for ENVIRO CHANNEL H 380, diameter 110 mm	1.18
4EC1SV	Chute	10.5

ECOLOGICALLY SUSTAINABLE DRAINAGE SYSTEMS

ENVIRO SERIES DECKS



Width 175/275/335 mm

Combined and compact drainage system with kerbs, suitable for bridges or sites featuring limited construction depth. Available with slightly sloping or inclined profile and variable depth. Thanks to the nature of the material and the production process, we are able to produce kerbs with different depths and profiles that are not included in the following table.



ADVANTAGES

- Constructed as a highly resistant monolithic unit.
- Ideal for areas featuring limited construction depth: concrete floor slabs, bridges, paved roads or structures, underpasses and crossover bridges.
- Three different widths available depending on the water out-flow.
- Easy sub-surface drainage for facilitating drying of the asphalt matrix.
- Conforming to the EN 1433 D400KN standard for the drainage kerb system.
- Lightweight, for easier installation (the heaviest product weighs 19 kg).
- Non-metallic and therefore not subject to oxidation.

DRAINAGE FOR BRIDGES AND LOW DEPTHS

Following the widespread success of Enviro road drainage products, GRIDIRON has introduced the NEW EnviroDeck system for structures and constructions with limited depth.

The product possesses all the advantages of the Enviro range, including excellent impact resistance, light weight for easier handling, concrete-like appearance and, of course, the advantage of a product made with 100% of recycled material. The product is available with

150 mm, 220 mm and 310 mm width and various depths, depending on the requested profile of the kerb (75 mm, 100 mm or 125 mm).

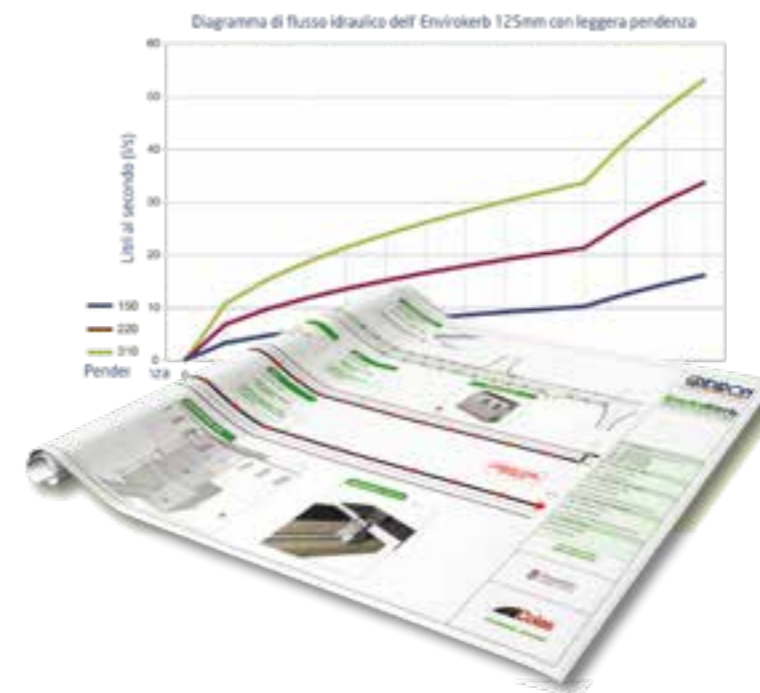

DRAINAGE FOR BRIDGES AND LOW DEPTHS

The NEW Enviro Deck unit was designed to replace the heavy ductile iron units. Various elements must be verified to assess the necessary width and depth.

The depth depends on the kerb profile and adapter; the available depths are 75 mm, 100 mm or 125 mm, with the total final depth being determined by the road construction depth.

The width is based solely on the expected water flow, coupled with the longitudinal slope of the road surface. Gridiron can easily determine this parameter based on the project drawing, which shows the levels and a section of the road.

We can determine the size of the unit (see adjacent graph for quick reference), in order to offer the most convenient width from a hydraulic and economic perspective. Contact our technical department: we will be pleased to make the relative calculations for your project.

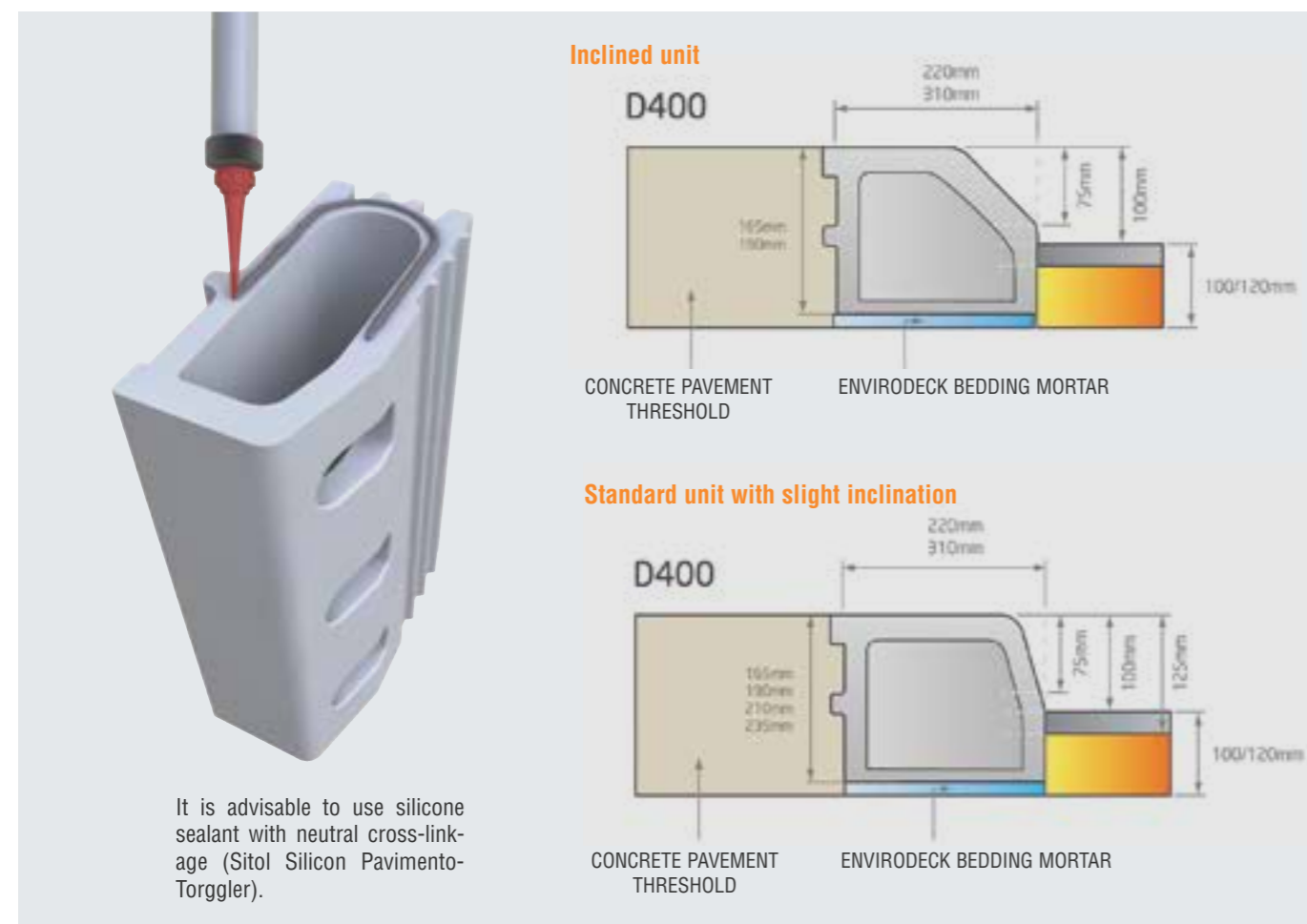

INSTALLATION INSTRUCTIONS

DRAINAGE FOR BRIDGES AND LOW DEPTHS.

The drainage system for ENVIRO DECK bridges is normally installed on a concrete bridge or paving, which acts as a base. If the system must be installed on soft ground or compacted rock, consult the installation instructions for the standard ENVIRODECK system. The units are secured with bedding mortar for drainage systems or with a similar product.

- 1) Position the units prior to installation to make sure that all the inspection units, sump units and assembled expansion joints are positioned correctly.
- 2) We suggest first installing the assembled expansion joints, as their length cannot be modified.
- 3) Install the system in line and level. We recommend finding the highest point of the bridge/structure and using it to determine the various levels, so as to reduce the thickness of the bedding mortar.
- 4) The sealant must be applied to the unit before it is positioned; subsequently, join the units together keeping the joints clean of any residual bedding mortar.
- 5) The units can be cut.
- 6) Please note that, pursuant to the EN 1433 standard, all types of kerbs must be tested to verify their water-tightness; the units must then be sealed to guarantee compliance.

ECOLOGICALLY SUSTAINABLE DRAINAGE SYSTEMS

ENVIRO SERIES DECKS



INSPECTION UNIT FOR ENVIRO DECK KERB

STANDARD UNIT



ENVIRO DECK kerb dimensions

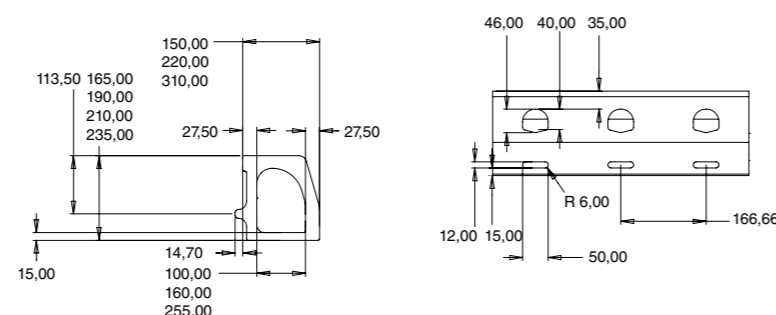

Enviro Deck kerbs - length 500 mm

Code	Description	Water passage mm	External height mm	Total width mm	Kerb profile height mm	Weight kg	Pieces pallet	Load class
4ED11S	ENVIRO DECK 150 standard draining kerb	100	165	150	75	9.20	120	D 400
4ED51S	ENVIRO DECK 150 draining kerb with inclined front	100	165	150	75	9.20	120	
4ED12S	ENVIRO DECK 150 standard draining kerb	100	190	150	100	9.60	108	
4ED52S	ENVIRO DECK 150 draining kerb with inclined front	100	190	150	100	9.60	108	
4ED13S	ENVIRO DECK 150 standard draining kerb	100	210	150	125	10.00	84	
4ED53S	ENVIRO DECK 150 draining kerb with inclined front	100	210	150	125	10.00	84	
4ED21S	ENVIRO DECK 220 standard draining kerb	160	165	220	75	12.00	100	
4ED61S	ENVIRO DECK 220 draining kerb with inclined front	160	165	220	75	12.00	100	
4ED22S	ENVIRO DECK 220 standard draining kerb	160	190	220	100	12.50	80	
4ED62S	ENVIRO DECK 220 draining kerb with inclined front	160	190	220	100	12.50	80	
4ED23S	ENVIRO DECK 220 standard draining kerb	160	210	220	125	13.50	80	
4ED63S	ENVIRO DECK 220 draining kerb with inclined front	160	210	220	125	13.50	80	
4ED24S	ENVIRO DECK 220 standard draining kerb	160	235	220	125	14.50	80	
4ED64S	ENVIRO DECK 220 draining kerb with inclined front	160	235	220	125	14.50	80	
4ED31S	ENVIRO DECK 310 standard draining kerb	255	165	310	75	21.00	56	
4ED71S	ENVIRO DECK 310 draining kerb with inclined front	255	165	310	75	21.00	56	
4ED32S	ENVIRO DECK 310 standard draining kerb	255	190	310	100	22.00	56	
4ED72S	ENVIRO DECK 310 draining kerb with inclined front	255	190	310	100	22.00	56	
4ED33S	ENVIRO DECK 310 standard draining kerb	255	210	310	125	23.00	49	
4ED73S	ENVIRO DECK 310 draining kerb with inclined front	255	210	310	125	23.00	49	
4ED34S	ENVIRO DECK 310 standard draining kerb	255	235	310	125	24.00	49	
4ED74S	ENVIRO DECK 310 draining kerb with inclined front	255	235	310	125	24.00	49	

Inspection unit for Enviro Deck kerbs - length 500 mm

Code	Description	Water passage mm	External height mm	Total width mm	Kerb profile height mm	Weight kg	Load class
4ED11C	Inspection unit for ENVIRO DECK 150 standard kerb with solid cover made of composite resin secured with screws	100	165	150	75	9.20	D 400
4ED51C	Inspection unit for ENVIRO DECK 150 kerb with inclined front and solid cover made of composite resin secured with screws	100	165	150	75	9.20	
4ED12C	Inspection unit for ENVIRO DECK 150 standard kerb with solid cover made of composite resin secured with screws	100	190	150	100	9.60	
4ED52C	Inspection unit for ENVIRO DECK 150 kerb with inclined front and solid cover made of composite resin secured with screws	100	190	150	100	9.60	
4ED13C	Inspection unit for ENVIRO DECK 150 standard kerb with solid cover made of composite resin secured with screws	100	210	150	125	10.00	
4ED53C	Inspection unit for ENVIRO DECK 150 kerb with inclined front and solid cover made of composite resin secured with screws	100	210	150	125	10.00	
4ED21C	Inspection unit for ENVIRO DECK 220 standard kerb with solid cover made of composite resin secured with screws	160	165	220	75	12.00	
4ED61C	Inspection unit for ENVIRO DECK 220 kerb with inclined front and solid cover made of composite resin secured with screws	160	165	220	75	12.00	
4ED22C	Inspection unit for ENVIRO DECK 220 standard kerb with solid cover made of composite resin secured with screws	160	190	220	100	12.50	
4ED62C	Inspection unit for ENVIRO DECK 220 kerb with inclined front and solid cover made of composite resin secured with screws	160	190	220	100	12.50	
4ED23C	Inspection unit for ENVIRO DECK 220 standard kerb with solid cover made of composite resin secured with screws	160	210	220	125	13.50	
4ED63C	Inspection unit for ENVIRO DECK 220 kerb with inclined front and solid cover made of composite resin secured with screws	160	210	220	125	13.50	
4ED24C	Inspection unit for ENVIRO DECK 220 standard kerb with solid cover made of composite resin secured with screws	160	235	220	125	14.50	
4ED64C	Inspection unit for ENVIRO DECK 220 kerb with inclined front and solid cover made of composite resin secured with screws	160	235	220	125	14.50	
4ED31C	Inspection unit for ENVIRO DECK 310 standard kerb with solid cover made of composite resin secured with screws	255	165	310	75	21.00	
4ED71C	Inspection unit for ENVIRO DECK 310 kerb with inclined front and solid cover made of composite resin secured with screws	255	165	310	75	21.00	
4ED32C	Inspection unit for ENVIRO DECK 310 standard kerb with solid cover made of composite resin secured with screws	255	190	310	100	22.00	
4ED72C	Inspection unit for ENVIRO DECK 310 kerb with inclined front and solid cover made of composite resin secured with screws	255	190	310	100	22.00	
4ED33C	Inspection unit for ENVIRO DECK 310 standard kerb with solid cover made of composite resin secured with screws	255	210	310	125	23.00	
4ED73C	Inspection unit for ENVIRO DECK 310 kerb with inclined front and solid cover made of composite resin secured with screws	255	210	310	125	23.00	
4ED34C	Inspection unit for ENVIRO DECK 310 standard kerb with solid cover made of composite resin secured with screws	255	235	310	125	24.00	
4ED74C	Inspection unit for ENVIRO DECK 310 kerb with inclined front and solid cover made of composite resin secured with screws	255	235	310	125	24.00	

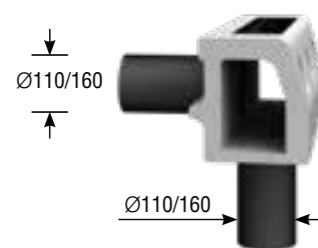

SUMP UNIT FOR ENVIRODECK KERB WITH SIDE OR BOTTOM OUTLET

Enviro Deck kerbs - length 500 mm

Code	Description	Water passage mm	External height mm	Total width mm	Kerb profile height mm	Weight kg	Load class
4ED11P	Sump unit for ENVIRO DECK 150 standard kerb with solid cover made of composite resin secured with screws	100	165	150	75	9.20	D 400
4ED51P	Sump unit for ENVIRO DECK 150 kerb with inclined front and solid cover made of composite resin secured with screws	100	165	150	75	9.20	
4ED12P	Sump unit for ENVIRO DECK 150 standard kerb with solid cover made of composite resin secured with screws	100	190	150	100	9.60	
4ED52P	Sump unit for ENVIRO DECK 150 kerb with inclined front and solid cover made of composite resin secured with screws	100	190	150	100	9.60	
4ED13P	Sump unit for ENVIRO DECK 150 standard kerb with solid cover made of composite resin secured with screws	100	210	150	125	10.00	
4ED53P	Sump unit for ENVIRO DECK 150 kerb with inclined front and solid cover made of composite resin secured with screws	100	210	150	125	10.00	
4ED21P	Sump unit for ENVIRO DECK 220 standard kerb with solid cover made of composite resin secured with screws	160	165	220	75	12.00	
4ED61P	Sump unit for ENVIRO DECK 220 kerb with inclined front and solid cover made of composite resin secured with screws	160	165	220	75	12.00	
4ED22P	Sump unit for ENVIRO DECK 220 standard kerb with solid cover made of composite resin secured with screws	160	190	220	100	12.50	
4ED62P	Sump unit for ENVIRO DECK 220 kerb with inclined front and solid cover made of composite resin secured with screws	160	190	220	100	12.50	
4ED23P	Sump unit for ENVIRO DECK 220 standard kerb with solid cover made of composite resin secured with screws	160	210	220	125	13.50	
4ED63P	Sump unit for ENVIRO DECK 220 kerb with inclined front and solid cover made of composite resin secured with screws	160	210	220	125	13.50	
4ED24P	Sump unit for ENVIRO DECK 220 standard kerb with solid cover made of composite resin secured with screws	160	235	220	125	14.50	
4ED64P	Sump unit for ENVIRO DECK 220 kerb with inclined front and solid cover made of composite resin secured with screws	160	235	220	125	14.50	
4ED31P	Sump unit for ENVIRO DECK 310 standard kerb with solid cover made of composite resin secured with screws	255	165	310	75	21.00	
4ED71P	Sump unit for ENVIRO DECK 310 kerb with inclined front and solid cover made of composite resin secured with screws	255	165	310	75	21.00	
4ED32P	Sump unit for ENVIRO DECK 310 standard kerb with solid cover made of composite resin secured with screws	255	190	310	100	22.00	
4ED72P	Sump unit for ENVIRO DECK 310 kerb with inclined front and solid cover made of composite resin secured with screws	255	190	310	100	22.00	
4ED33P	Sump unit for ENVIRO DECK 310 standard kerb with solid cover made of composite resin secured with screws	255	210	310	125	23.00	
4ED73P	Sump unit for ENVIRO DECK 310 kerb with inclined front and solid cover made of composite resin secured with screws	255	210	310	125	23.00	
4ED34P	Sump unit for ENVIRO DECK 310 standard kerb with solid cover made of composite resin secured with screws	255	235	310	125	24.00	
4ED74P	Sump unit for ENVIRO DECK 310 kerb with inclined front and solid cover made of composite resin secured with screws	255	235	310	125	24.00	

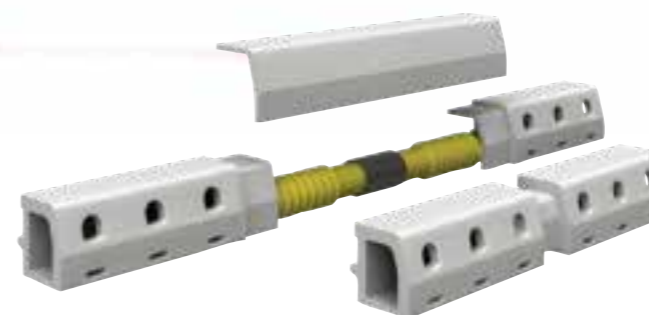

SLIDING OR STANDARD EXPANSION JOINTS

The assembled expansion joints are designed for connecting the expansion joints to the bridges. We have various standard units but are always willing to design and produce customised assemblies for difficult or large-sized joints.

Joint length mm	Code	Description	Weight kg	Load class
1,000	4ED1GS	Sliding assembled expansion joint for small movements for ENVIRODECK 150	25.00	D 400
	4ED2GS	Sliding assembled expansion joint for small movements for ENVIRODECK 220	30.00	
	4ED3GS	Sliding assembled expansion joint for small movements for ENVIRODECK 310	55.00	
2,000	4ED1G	Assembled expansion joint for ENVIRO DECK 150.	35.00	
	4ED2G	Assembled expansion joint for ENVIRO DECK 220.	40.00	
	4ED3G	Assembled expansion joint for ENVIRO DECK 310.	65.00	

Installation accessories

Code	Description
4EZ1PS	Silicone injection gun
4EZ1CS	Silicone cartridge (1 bottle for every 10 pieces)

ECOLOGICALLY SUSTAINABLE DRAINAGE SYSTEMS

ENVIRO SERIES KERBS



To complete the ecologically sustainable drainage range, GRIDIRON has introduced ENVIRO KERB, a combined system that unifies the kerb and drainage of the road into a single principle.

ENVIRO KERB is a monobloc element entirely made of recycled materials, which can be used for roads subject to high traffic, parking areas, highway junctions, traffic calming areas, roundabouts, and industrialised and urban areas. It is ABSOLUTELY the lightest product available on the market (up to 70% lighter compared to traditional products) while guaranteeing greater shock resistance and durability. Choosing ENVIRO KERB allows for having the following advantages:

- **Lightness:** its mere 15 kg weight makes manual installation easy;
- **Resistance:** improved resistance to shocks, frost-thaw cycles, hydrocarbons and salts;
- **100% RECYCLED;**
- **Conforming to the EN 1433 standard for linear drainage systems, D400 Load Class.**

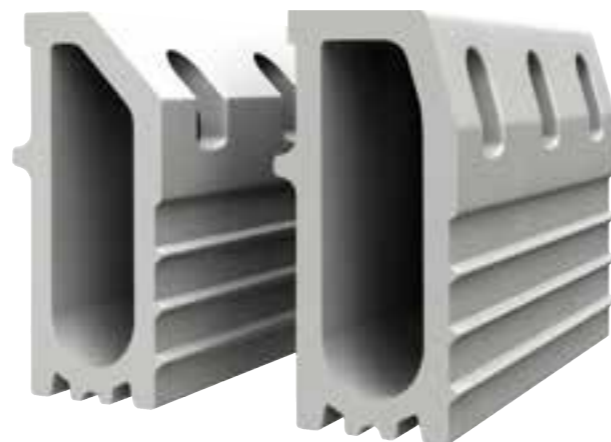

If there is a layer of asphalt behind the units, the concrete can be adapted by lowering the concrete side. All the stone pavement blocks adjacent to the kerb must be secured with modified polymer or epoxy mortar.

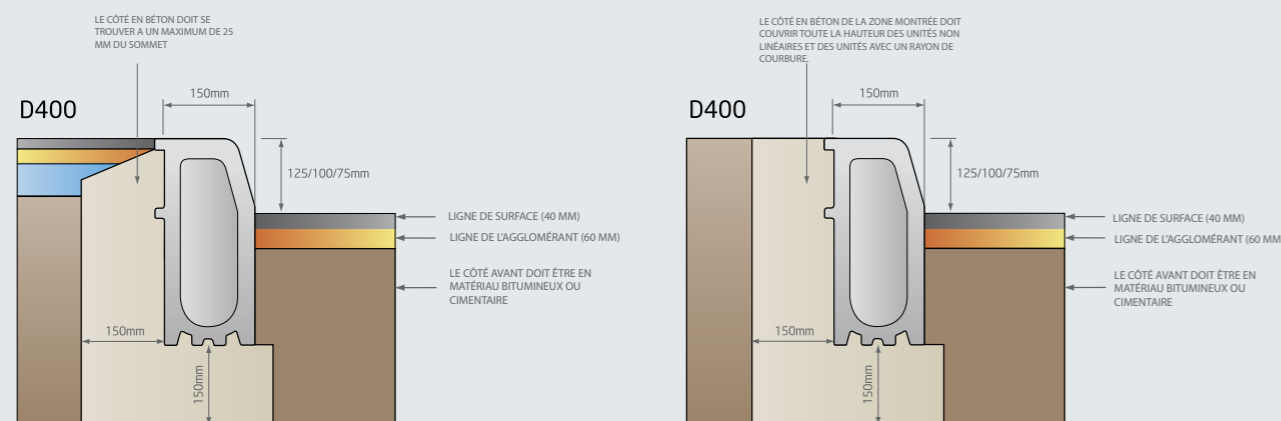

N.B.: the EN 1433 standard is clear and concise. All combined kerb products must be tested for water-tightness, therefore all units must be sealed for conformity reasons.

INSTALLATION INSTRUCTIONS

Envirokerb is manufactured in compliance with Load Class D400kn of the EN 1433 standard. The specifications concerning installation and the concrete edges/sides constitute an integral part of this standard.

- 1) Remove the ground longitudinally and level it.
- 2) Make a concrete bed to ensure correct installation.
- 3) Position the units prior to installation to ensure that all inspection units and sump units are positioned correctly.
- 4) Position the sump unit first then proceed with the standard units; the correct alignment and levelling should be pre-determined.
- 5) Seal the units still to be positioned then line them up, while keeping the connection points clean from concrete residues.
- 6) The asphalt can be spread at the base of the drainage unit for 125 mm in the front part of the kerb, or at the water level for 75/100 mm (again on the front part of the kerb).

INSTALLATION EXAMPLES

Standard unit

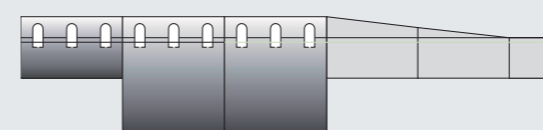

Inspection unit and sump unit

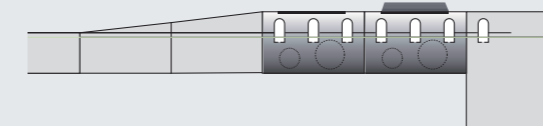

Straight central unit for vehicle passageways



Left and right descent units for vehicle passageways



Unit with interior and exterior radius of curvature

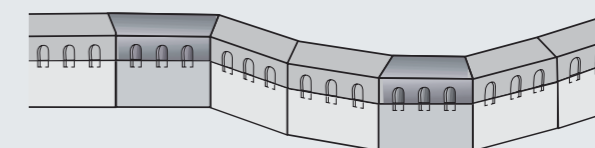

Inspection sump unit with ductile iron cover

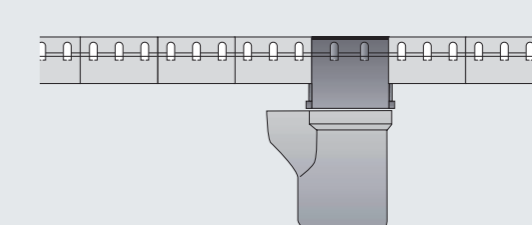

Unit for 90° inner and outer corner

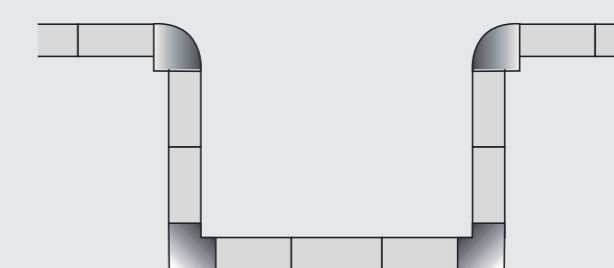

STANDARD AND INCLINED UNITS



ENVIRO KERB dimensions

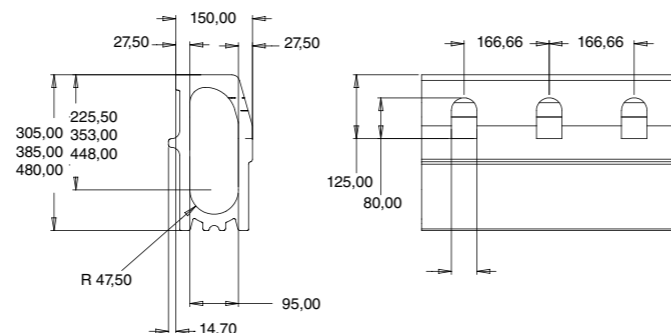

Enviro Kerbs - length 500 mm

Code	Description	Water passage mm	External height mm	Total width mm	Kerb profile height mm	Weight kg	Pieces pallet	Load class
4EK1S	ENVIRO KERB 305 standard draining kerb	100	305	150	75	15.00	60	D 400
4EK5S	ENVIRO KERB 305 draining kerb with inclined front	100	305	150	75	15.00	60	
4EK1S1	ENVIRO KERB 305 standard draining kerb	100	305	150	100	15.00	60	
4EK5S1	ENVIRO KERB 305 draining kerb with inclined front	100	305	150	100	15.00	60	
4EK1S2	ENVIRO KERB 305 standard draining kerb	100	305	150	125	15.00	60	
4EK5S2	ENVIRO KERB 305 draining kerb with inclined front	100	305	150	125	15.00	60	
4EK2S	ENVIRO KERB 385 standard draining kerb	100	385	150	75	18.00	48	
4EK6S	ENVIRO KERB 385 draining kerb with inclined front	100	385	150	75	18.00	48	
4EK2S1	ENVIRO KERB 385 standard draining kerb	100	385	150	100	18.00	48	
4EK6S1	ENVIRO KERB 385 draining kerb with inclined front	100	385	150	100	18.00	48	
4EK2S2	ENVIRO KERB 385 standard draining kerb	100	385	150	125	18.00	48	
4EK6S2	ENVIRO KERB 385 draining kerb with inclined front	100	385	150	125	18.00	48	
4EK3S	ENVIRO KERB 480 standard draining kerb	100	480	150	75	24.00	36	
4EK7S	ENVIRO KERB 480 draining kerb with inclined front	100	480	150	75	24.00	36	
4EK3S1	ENVIRO KERB 480 standard draining kerb	100	480	150	100	24.00	36	
4EK7S1	ENVIRO KERB 480 draining kerb with inclined front	100	480	150	100	24.00	36	
4EK3S2	ENVIRO KERB 480 standard draining kerb	100	480	150	125	24.00	36	
4EK7S2	ENVIRO KERB 480 draining kerb with inclined front	100	480	150	125	24.00	36	



INSPECTION UNITS

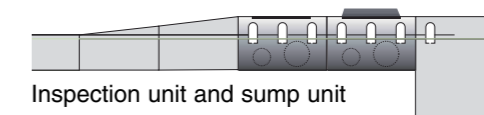

Inspection unit for Enviro Kerb - length 500 mm

Code	Description	Water passage mm	External height mm	Total width mm	Kerb profile height mm	Weight kg	Load class
4EK1C	Inspection unit for ENVIRO KERB 305 standard kerb with solid cover made of composite resin secured with screws	100	305	150	75	15.00	D 400
4EK5C	Inspection unit for ENVIRO KERB 305 kerb with inclined front and solid cover made of composite resin secured with screws	100	305	150	75	15.00	
4EK1C1	Inspection unit for ENVIRO KERB 305 standard kerb with solid cover made of composite resin secured with screws	100	305	150	100	15.00	
4EK5C1	Inspection unit for ENVIRO KERB 305 kerb with inclined front and solid cover made of composite resin secured with screws	100	305	150	100	15.00	
4EK1C2	Inspection unit for ENVIRO KERB 305 standard kerb with solid cover made of composite resin secured with screws	100	305	150	125	15.00	
4EK5C2	Inspection unit for ENVIRO KERB 305 kerb with inclined front and solid cover made of composite resin secured with screws	100	305	150	125	15.00	
4EK2C	Inspection unit for ENVIRO KERB 385 standard kerb with solid cover made of composite resin secured with screws	100	385	150	75	18.00	
4EK6C	Inspection unit for ENVIRO KERB 385 kerb with inclined front and solid cover made of composite resin secured with screws	100	385	150	75	18.00	
4EK2C1	Inspection unit for ENVIRO KERB 385 standard kerb with solid cover made of composite resin secured with screws	100	385	150	100	18.00	
4EK6C1	Inspection unit for ENVIRO KERB 385 kerb with inclined front and solid cover made of composite resin secured with screws	100	385	150	100	18.00	
4EK2C2	Inspection unit for ENVIRO KERB 385 standard kerb with solid cover made of composite resin secured with screws	100	385	150	125	18.00	
4EK6C2	Inspection unit for ENVIRO KERB 385 kerb with inclined front and solid cover made of composite resin secured with screws	100	385	150	125	18.00	
4EK3C	Inspection unit for ENVIRO KERB 480 standard kerb with solid cover made of composite resin secured with screws	100	480	150	75	24.00	
4EK7C	Inspection unit for ENVIRO KERB 480 kerb with inclined front and solid cover made of composite resin secured with screws	100	480	150	75	24.00	
4EK3C1	Inspection unit for ENVIRO KERB 480 standard kerb with solid cover made of composite resin secured with screws	100	480	150	100	24.00	
4EK7C1	Inspection unit for ENVIRO KERB 480 kerb with inclined front and solid cover made of composite resin secured with screws	100	480	150	100	24.00	
4EK3C2	Inspection unit for ENVIRO KERB 480 standard kerb with solid cover made of composite resin secured with screws	100	480	150	125	24.00	
4EK7C2	Inspection unit for ENVIRO KERB 480 kerb with inclined front and solid cover made of composite resin secured with screws	100	480	150	125	24.00	



SUMP UNIT



LEFT AND RIGHT SLOPING KERB FOR VEHICLE PASSAGeways

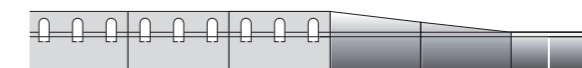

Left and right descent units for vehicle passageways

Enviro Kerbs - length 500 mm

Code	Description	Water passage mm	External height mm	Total width mm	Kerb profile height mm	Weight kg	Load class
4EK1P	Sump unit for ENVIRO KERB 305 standard kerb with solid cover made of composite resin secured with screws	100	305	150	75	15.00	D 400
4EK5P	Sump unit for ENVIRO KERB 305 kerb with inclined front and solid cover made of composite resin secured with screws	100	305	150	75	15.00	
4EK1P1	Sump unit for ENVIRO KERB 305 standard kerb with solid cover made of composite resin secured with screws	100	305	150	100	15.00	
4EK5P1	Sump unit for ENVIRO KERB 305 kerb with inclined front and solid cover made of composite resin secured with screws	100	305	150	100	15.00	
4EK1P2	Sump unit for ENVIRO KERB 305 standard kerb with solid cover made of composite resin secured with screws	100	305	150	125	15.00	
4EK5P2	Sump unit for ENVIRO KERB 305 kerb with inclined front and solid cover made of composite resin secured with screws	100	305	150	125	15.00	
4EK2P	Sump unit for ENVIRO KERB 385 standard kerb with solid cover made of composite resin secured with screws	100	385	150	75	18.00	
4EK6P	Sump unit for ENVIRO KERB 385 kerb with inclined front and solid cover made of composite resin secured with screws	100	385	150	75	18.00	
4EK2P1	Sump unit for ENVIRO KERB 385 standard kerb with solid cover made of composite resin secured with screws	100	385	150	100	18.00	
4EK6P1	Sump unit for ENVIRO KERB 385 kerb with inclined front and solid cover made of composite resin secured with screws	100	385	150	100	18.00	
4EK2P2	Sump unit for ENVIRO KERB 385 standard kerb with solid cover made of composite resin secured with screws	100	385	150	125	18.00	
4EK6P2	Sump unit for ENVIRO KERB 385 kerb with inclined front and solid cover made of composite resin secured with screws	100	385	150	125	18.00	
4EK3P	Sump unit for ENVIRO KERB 480 standard kerb with solid cover made of composite resin secured with screws	100	480	150	75	24.00	
4EK7P	Sump unit for ENVIRO KERB 480 kerb with inclined front and solid cover made of composite resin secured with screws	100	480	150	75	24.00	
4EK3P1	Sump unit for ENVIRO KERB 480 standard kerb with solid cover made of composite resin secured with screws	100	480	150	100	24.00	
4EK7P1	Sump unit for ENVIRO KERB 480 kerb with inclined front and solid cover made of composite resin secured with screws	100	480	150	100	24.00	
4EK3P2	Sump unit for ENVIRO KERB 480 standard kerb with solid cover made of composite resin secured with screws	100	480	150	125	24.00	
4EK7P2	Sump unit for ENVIRO KERB 480 kerb with inclined front and solid cover made of composite resin secured with screws	100	480	150	125	24.00	

Enviro Kerbs - length 500 mm

Code	Description	Water passage mm	Initial height mm	Final height mm	Weight kg	Load class
4EK1DX	Sloping kerb for vehicle passageways HIGH RIGHT ELEMENT for standard ENVIRO KERB 305	100	305	255	15.00	D 400
4EK1SX	Sloping kerb for vehicle passageways HIGH LEFT ELEMENT for standard ENVIRO KERB 305	100	305	255	15.00	
4EK2DX	Sloping kerb for vehicle passageways HIGH RIGHT ELEMENT for ENVIRO KERB 385 standard	100	385	335	16.50	
4EK2SX	Sloping kerb for vehicle passageways HIGH LEFT ELEMENT for standard ENVIRO KERB 385	100	385	335	16.50	
4EK3DX	Sloping kerb for vehicle passageways HIGH RIGHT ELEMENT for ENVIRO KERB 480 standard	100	480	430	22.00	
4EK3SX	Sloping kerb for vehicle passageways HIGH LEFT ELEMENT for ENVIRO KERB 480 standard	100	480	430	22.00	
4EK1DY	Sloping kerb for vehicle passageways LOW RIGHT ELEMENT for standard ENVIRO KERB 305	100	255	205	15.00	
4EK1SY	Sloping kerb for vehicle passageways LOW LEFT ELEMENT for standard ENVIRO KERB 305	100	255	205	15.00	
4EK2DY	Sloping kerb for vehicle passageways LOW RIGHT ELEMENT for standard ENVIRO KERB 385	100	335	285	16.50	
4EK2SY	Sloping kerb for vehicle passageways LOW LEFT ELEMENT for standard ENVIRO KERB 385	100	335	285	16.50	
4EK3DY	Sloping kerb for vehicle passageways LOW RIGHT ELEMENT for standard ENVIRO KERB 480	100	430	380	22.00	
4EK3SY	Sloping kerb for vehicle passageways LOW LEFT ELEMENT for standard ENVIRO KERB 480	100	430	380	22.00	
4EK5DX	RIGHT CONNECTION kerb WITH GRADUALLY INCLINED FRONT on vehicle passageway only required for model ENVIRO KERB 305 with inclined front	100	-	-	22.00	
4EK5SX	LEFT CONNECTION kerb WITH GRADUALLY INCLINED FRONT on vehicle passageway only required for model ENVIRO KERB 305 with inclined front	100	-	-	22.00	
4EK6DX	RIGHT CONNECTION kerb WITH GRADUALLY INCLINED FRONT on vehicle passageway only required for model ENVIRO KERB 385 with inclined front	100	-	-	22.00	
4EK6SX	LEFT CONNECTION kerb WITH GRADUALLY INCLINED FRONT on vehicle passageway only required for model ENVIRO KERB 385 with inclined front	100	-	-	22.00	
4EK7DX	RIGHT CONNECTION kerb WITH GRADUALLY INCLINED FRONT on vehicle passageway only required for model ENVIRO KERB 480 with inclined front	100	-	-	22.00	
4EK7SX	LEFT CONNECTION kerb WITH GRADUALLY INCLINED FRONT on vehicle passageway only required for model ENVIRO KERB 480 with inclined front	100	-	-	22.00	



SOLID OR DRAINING STRAIGHT CENTRAL KERB FOR VEHICLE PASSAGeways



Straight central unit for vehicle passageways

Enviro Kerbs - length 500 mm

Code	Description	Water passage mm	External height mm	Total width mm	Kerb profile height mm	Weight kg	Load class
4EK1R	Solid straight central kerb for vehicle passageway for ENVIRO KERB 305	100	205	205	11.50	120.00	D 400
4EK1RF	Solid straight draining central kerb with holes for vehicle passageway for ENVIRO KERB 305	100	205	205	11.50	120.00	
4EK2R	Solid straight central kerb for vehicle passageway for ENVIRO KERB 385	100	285	285	15.00	108.00	
4EK2RF	Solid straight draining central kerb with holes for vehicle passageway for ENVIRO KERB 385	100	285	285	15.00	108.00	
4EK3R	Solid straight central kerb for vehicle passageway for ENVIRO KERB 480	100	380	380	18.50	84.00	
4EK3RF	Solid straight draining central kerb with holes for vehicle passageway for ENVIRO KERB 480	100	380	380	18.50	84.00	

N.B.: for creating long straight sections, solid or perforated kerbs are available with H 180 - 260 - 355 mm



INSPECTION SUMP UNIT WITH DUCTILE IRON COVER

The upper part of the sump unit is made of ductile iron, in compliance with the D400 load class specified in the EN 1433 standard applicable to kerb covers. The cover is equipped with pins and can remain lifted to facilitate sump maintenance and cleaning. The base of the sump unit is specially modelled to offer greater resistance to load pressure and enhanced wall resistance, and is entirely made of recycled material. The draining units can be placed on both sides of the sump unit.

Enviro Kerb sump units - length 500 mm

Code	Description	Total height mm	Total width mm	Weight kg	Load class
4EK1PS	Inspection sump unit with ductile iron cover for ENVIRO KERB 305.	505	390	47.00	D 400
4EK2PS	Inspection sump unit with ductile iron cover for ENVIRO KERB 385.	505	390	47.00	
4EK3PS	Inspection sump unit with ductile iron cover for ENVIRO KERB 480.	505	390	47.00	



SOLID KERB FOR 90° INNER AND OUTER CORNER

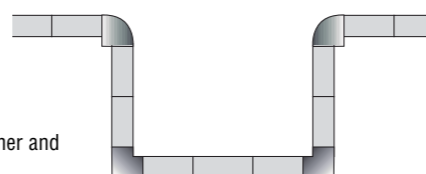

Unit for 90° inner and outer corner

Enviro Kerbs - length 500 mm

Kerb L mm	Code	Description	Water passage mm	Total height mm	Weight kg	Load class
305	4EK1AE	Rounded (OUTER) blind corner kerb for ENVIRO KERB 305	100	305	16.50	D 400
	4EK2AE	Rounded (OUTER) blind corner kerb for ENVIRO KERB 385	100	385	17.00	
	4EK3AE	Rounded (OUTER) blind corner kerb for ENVIRO KERB 480	100	480	18.00	
500	4EK1AI	Solid corner (INNER) kerb for ENVIRO KERB 305	100	305	19.00	
	4EK2AI	Solid corner (INNER) kerb for ENVIRO KERB 385	100	385	20.00	
	4EK3AI	Solid corner (INNER) kerb for ENVIRO KERB 480	100	480	21.00	

KERB WITH INTERIOR AND EXTERIOR RADIUS OF CURVATURE

Gridiron is able to provide units with radius of curvature suited to the requirements of the various sites. An extensive range of radii of curvature – from 4 lm to 14 lm – is available. The linear units can be used to form a radius of curvature exceeding 14 lm using the joints, as the units only measure 500 mm in length.

Installation accessories

Code	Description
4EZ1PS	Silicone injection gun
4EZ1CS	Silicone cartridge (1 bottle for every 10 pieces)

ECOLOGICALLY SUSTAINABLE DRAINAGE SYSTEMS
ENVIRO SERIES KERBS



KERB FOR CABLE PASSAGE



Enviro IT Kerbs - length 500 mm

Code	Description	Water passage mm	External height mm	Total width mm	Kerb profile height mm	Weight kg	Load class
4ET1SC	IT KERB 305 standard SOLID kerb for cable passage	100	305	150	75	15.00	D 400
4ET5SC	IT KERB 305 SOLID kerb for cable passage with inclined front	100	305	150	75	15.00	
4ET1SC1	IT KERB 305 standard SOLID kerb for cable passage	100	305	150	100	15.00	
4ET5SC1	IT KERB 305 SOLID kerb for cable passage with inclined front	100	305	150	100	15.00	
4ET1SC2	IT KERB 305 standard SOLID kerb for cable passage	100	305	150	125	15.00	
4ET5SC2	IT KERB 305 SOLID kerb for cable passage with inclined front	100	305	150	125	15.00	
4ET2SC	IT KERB 385 standard SOLID kerb for cable passage	100	385	150	75	18.00	
4ET6SC	IT KERB 385 SOLID kerb for cable passage with inclined front	100	385	150	75	18.00	
4ET2SC1	IT KERB 385 standard SOLID kerb for cable passage	100	385	150	100	18.00	
4ET6SC1	IT KERB 385 SOLID kerb for cable passage with inclined front	100	385	150	100	18.00	
4ET2SC2	IT KERB 385 standard SOLID kerb for cable passage	100	385	150	125	18.00	
4ET6SC2	IT KERB 385 SOLID kerb for cable passage with inclined front	100	385	150	125	18.00	
4ET3SC	IT KERB 480 standard SOLID kerb for cable passage	100	480	150	75	24.00	
4ET7SC	IT KERB 480 SOLID kerb for cable passage with inclined front	100	480	150	75	24.00	
4ET3SC1	IT KERB 480 standard SOLID kerb for cable passage	100	480	150	100	24.00	
4ET7SC1	IT KERB 480 SOLID kerb for cable passage with inclined front	100	480	150	100	24.00	
4ET3SC2	IT KERB 480 standard SOLID kerb for cable passage	100	480	150	125	24.00	
4ET7SC2	IT KERB 480 SOLID kerb for cable passage with inclined front	100	480	150	125	24.00	

Installation accessories

Code	Description
4EZ1PS	Silicone injection gun
4EZ1CS	Silicone cartridge (1 bottle for every 10 pieces)

GRIDIRON®

TECHNICAL DATA

PAGE
304

HYDRAULIC CALCULATIONS

PAGE
304

FLOW RATE TABLES

PAGE
306

LOAD CLASSES

PAGE
308

INSTALLATION, USE AND MAINTENANCE SHEETS

PAGE
309

GLOSSARY

GRIDIRON®
BUILD YOUR CHANGES

TECHNICAL DATA

HYDRAULIC CALCULATIONS

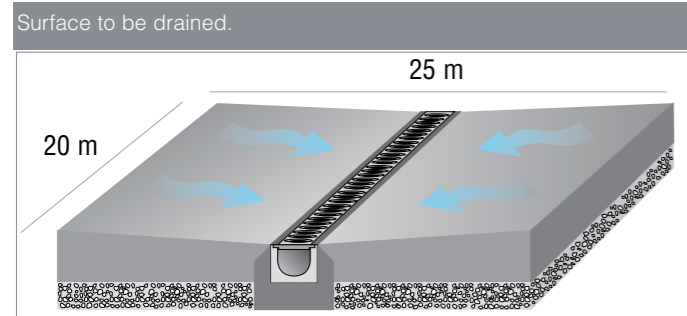

Formula for defining the amount of water to be drained:

Qt = amount of water to be drained

A = surface area to be drained

P = average amount of precipitation

Qt = A P

To determine, for example, the amount of water to be drained

from a 25x20 m surface located in Northern Italy, we have:

A = 25 x 20 m = 500 m²

P = 103 mm/hour

Qt = 500 x 103 = 51,500 mm/hour

51,500 mm/hour corresponds to 14.3 mm/second, equivalent to 14.3 litres/second.

After deciding which type of grating is required, based on the required load resistance of the channels, the next step involves choosing the right channel size in relation to the amount of water to be drained. The channel will therefore be sized taking into account the relevant surface and the geographical area in which it is located.

- The surface to be drained is the area from which the channel must let the water run off.
- The geographical zone determines the average amount of precipitation based on the following table:

Average precipitation

Northern Italy	103	mm
Central Italy	53	mm
Southern Italy	25	mm
Sicily	10	mm
Sardinia	19	mm



TABLE 1 ON THE FOLLOWING PAGE LISTS ALL THE WATER FLOW RATES OF GRIDIRON CHANNELS CALCULATED USING THE FOLLOWING FORMULAS:

$$Q = A V$$

CHÈZY-TADINI formula

$$V = c \sqrt{Ri}$$

BAZIN formula

$$c = \frac{87}{1 + \frac{\gamma}{\sqrt{R}}}$$

The symbols used in the formulas refer to the following:

Q = flow rate in m³/second

A = water passage section of the channel in m²

K = water line in m

V = average speed in m/second

c = friction coefficient

R = average radius in m

i = channel slope

γ = roughness coefficient

FLOW RATE TABLES

Gridiron channel water flow rate					Table 1					
Channels	Area	Water line	Roughness coefficient γ	Average radius	Slopes					
					0.5%	1%	1.50%	2%	3%	
Flow rate litres/second										
vibro-compressed concrete	VIBROBASE 100 h140	9926	277	0.12	35.8	7.1	10.0	12.3	14.2	17.4
	VIBROBASE 100 h165	12426	327	0.12	38.0	9.2	13.0	16.0	18.4	22.6
	VIBROBASE 100 h190	14926	377	0.12	39.6	11.5	16.2	19.9	23.0	28.1
	VIBROBASE 150 h200	22335	415	0.12	53.8	21.1	29.8	36.5	42.1	51.6
	VIBROBASE 150 h225	26085	465	0.12	56.1	25.5	36.1	44.2	51.0	62.5
	VIBROBASE 150 h250	29835	515	0.12	57.9	29.5	41.7	54.1	59.0	72.3
	VIBROBASE 200 h260	39707	554	0.12	17.7	45.3	64.1	78.4	90.6	110.9
	VIBROBASE 200 h285	44707	604	0.12	74.0	52.4	74.1	90.7	104.7	128.3
	VIBROBASE 200 h310	49707	654	0.12	76.0	59.2	83.8	102.6	118.5	145.19

FLOW RATE TABLES

Gridiron channel water flow rate					Table 1					
Channels	Area	Water line	Roughness coefficient γ	Average radius	Slopes					
					0.5%	1%	1.50%	2%	3%	
Flow rate litres/second										
vibro-compressed concrete	R122	4456	183	0,12	24,3	2,5	3,5	4,3	4,9	6,0
	R150 H1*	9127	281	0,12	32,5	6,1	8,7	10,6	12,3	15,0
	R150 H2*	5987	270	0,12	22,2	4,1	5,7	7	7,9	9,6
	R150 H3*	13301	387	0,12	34,4	8,9	12,6	15,2	17,6	21,2
	R210 H1*	21603	413	0,12	52	20,1	28,4	34,8	40,2	49,3
	R210 H2*	11500	280	0,12	41	9,1	12,9	15,8	18,3	22,4
	R210 H3*	34996	589	0,12	59	35,4	50,1	61,3	70,8	86,7
	R265 H1*	38150	558	0,12	68,4	42,3	59,8	73,3	84,6	103,7
	R265 H2*	18300	382	0,12	47,7	15,7	22,9	27,4	31,5	38,5
	R265 H3*	57700	767	0,12	73,3	64,3	90,6	110,6	127,7	115,8
	R315 H1*	56660	668	0,12	84,8	72,0	101,8	124,7	144,0	176,4
	R315 H2*	22459	397	0,12	56,5	20,9	29,5	35,9	41,3	50,4
	R315 H3*	77790	837	0,12	92,9	107,2	151,1	184,3	212,9	259,7
	R365*	83440	815	0,12	102,4	119,9	169,6	207,7	239,8	293,7
	R495 H1	140381	1056	0,12	132,9	237,0	335,1	410,4	473,9	580,5
	R495 H2	214869	1455	0,12	147,7	387,6	548,2	671,4	775,2	949,5
	R595 H1	224616	1340	0,12	167,6	438,1	619,6	758,8	876,2	1073,1
	R595 H2	271037	1539	0,12	176,1	545,8	771,9	945,4	1091,6	1336,9
reinforced concrete	K170	13502	359	0,12	37,6	10,0	14,2	17,4	20,0	24,5
	K220	24342	541	0,12	45	20,3	28,7	35,1	40,6	49,7
	K270	41940	614	0,12	68,3	46,5	65,8	80,6	93,0	114,0
	K270 RIBASSATO	20152	385	0,12	52,3	18,8	26,5	32,5	37,5	46,0
	K350	69167	773	0,12	89,5	91,2	128,9	157,9	182,4	223,3
	K400	97749	919	0,12	106,4	143,9	203,5	249,3	287,8	352,5
	C500	109967	943	0,12	116,6	171,3	242,3	296,7	342,6	419,6
	C600	143780	1047	0,12	137,3	248,4	351,2	430,2	496,7	608,3
	C700	225615	1328	0,12	169,9	443,3	626,9	767,7	886,5	1085,8
	C800	377300	1814	0,12	208,0	838,1	1185,2	1451,6	1676,1	2052,8
	XL410-H1	98700	884	0,10	112,0	156,0	221,0	271,0	313,0	383,0
	XL410-H2	161700	1280	0,10	126,0	277,0	391,0	479,0	554,0	678,0
	XL410-H3	233400	1790	0,10	130,0	407,0	576,0	705,0	814,0	997,0
XL410-H4	325600	2390	0,10	136,0	584,0	825,0	1011,0	1167,0	1430,0	
polymer concrete	BASE 100	6251	220	0,10	28,4	4,1	5,8	7,1	8,3	10,01
	BASE 100 LOW	2906	147	0,10	20	1,5	2,1	2,6	3,0	3,6
	BASE 150	17085	345	0,10	49,5	16,2	23,0	28,1	32,5	39,8
	BASE 200	31507	472	0,10	66,8	36,2	51,2	62,7	72,4	88,6
	P150*	9486	282	0,10	33,6	7,0	9,9	12,1	14,0	17,1
	P150 RIBASSATO	3958	173	0,10	22,9	2,2	3,1	3,9	4,5	5,5
	P210*	21002	400	0,10	52,5	20,7	29,3	35,9	41,5	50,8
	P210 RIBASSATO	8898	250	0,10	36	6,8	9,6	11,8	13,6	16,7
	P265*	36475	528	0,10	69,1	43,1	60,9	74,6	86,2	105,5
	P315*	53642	630	0,10	85,1	72,2	102,1	125,0	144,3	176,8
	P365*	83255	798	0,10	104,3	126	179,4	219,7	253,6	310,7
	POLY FLY 100	10878	297	0,10	37	8,5	12,0	14,7	16,9	20,7
	POLY FLY 100 LOW	7042	222	0,10	32	5,0	7,0	8,6	9,9	12,2
	POLY FLY 100 CON PEND.	-	-	-	-	-	-	-	-	-
	POLY FLY 150	22054	416	0,10	53	22,0	31,2	38,2	44,1	54,0
	POLY FLY 150 LOW	9365	257	0,10	36	7,3	10,3	12,6	14,6	17,9
	POLY FLY 200	44801	600	0,10	75	55,3	78,2	95,8	110,6	135,4
	POLY FLY 200 LOW	13756	320	0,10	43	11,8	16,7	20,5	23,7	29,0
	POLY FLY 300 HIGH	85524	845	0,1	101	128,0	181,0	221,6	255,9	313,4
	POLY FLY 300 MEDIUM	47728	588	0,10	81	62,3	88,1	107,9	124,6	152,6
	POLY FLY 300 LOW	32728	488	0,10	67	37,9	53,7	65,7	75,9	93,0
PLASTIC FLY 100	14238	369	0,10	39	11,5	16,2	19,9	23,0	28,1	
PLASTIC FLY 100 LOW	6899	221	0,10	31	4,9	6,9	8,4	9,7	11,9	
PLASTIC FLY 150	21688	419	0,10	52	21,1	29,9	36,6	42,3	51,8	
PLASTIC FLY 150 LOW	10593	270	0,10	39	8,7	12,3	15,0	17,4	21,3	
PLASTIC FLY 200	38118	551	0,10	69	45,0	63,7	78,0	90,0	110,3	
PLASTIC FLY 200 LOW	28357	452	0,10	63	31,3	44,3	54,2	62,6	76,7	

* With galvanised or ductile iron edge rail

It is important to always use an adequate drain pipe. The table below shows a diagram of the PVC pipe flow rates with various slopes.

Flow rates in litres/second of pipes with different installation slopes							
Diameter of PVC pipes in mm	Percentage slope						
	0.5%	1%	1.5%	2%	3%	5%	10%
40	0.15	0.26	0.30	0.35	0.43	0.57	0.80
50	0.37	0.52	0.60	0.73	0.89	1.14	1.61
63	0.73	1.04	1.28	1.47	1.77	2.28	3.16
75	1.21	1.63	2.10	2.41	2.94	3.80	5.35
80	1.44	2.05	2.51	2.88	3.54	4.56	6.44
100	2.78	3.91	4.78	5.57	6.78	8.75	12.34
125	5.20	7.36	8.99	10.40	13.00	16.41	23.19
140	6.91	9.78	11.96	13.80	16.90	21.81	30.93
160	9.80	13.74	16.86	19.46	23.86	30.76	43.57
200	16.94	24.01	29.40	33.96	41.61	53.70	75.78
250	30.09	42.54	52.06	60.15	73.64	95.10	134.60
315	54.48	77.11	94.32	108.90	133.40	172.00	244.50

LOAD CLASSES

CLASSIFICATION IN ACCORDANCE WITH THE UNI EN 1433 STANDARD

The use of linear drainage systems (channels) for areas subject to the passage of vehicles and pedestrians has now become standard practice, owing to the ease of installation, reliability and safety offered by this solution.

During the design phase, it is important to consider all the variables that determine the adequate sizing of the relevant channel, namely grating resistance, required water flow rate and their correct installation. The installation instructions provided below contain all the necessary instructions for installing channels and gratings in accordance with the UNI EN 1433 standard. Furthermore, please bear in mind that correct installation of the channels, according to our instructions, is an essential prerequisite for guaranteeing the load class specified in the UNI EN 1433 standard. The table below lists the relevant load classes in relation to the intended use, in compliance with the UNI EN 1433 standard. The choice of the channel type, size and load class depend on the specific project. Our technical office remains at your disposal for any further information.

Moreover, the UNI EN 1433 standard specifies that:

1. The gratings must be secured to the channel body and, from Class D400 onwards, should have a locking device.
2. From Class D400 onwards, the channel edges exposed to traffic must be protected, a feature recommended for load class C250.
3. The housings for gratings belonging to Classes D400 to F900 must be manufactured in such a way so as to guarantee stability and silence during use.

The table below lists the load resistance values required for drainage channel covers, depending on their intended use and in compliance with the UNI EN 1433 standard.

Symbols	Classes	Resistance	Description - Fields of application
	A 15	kN 15	Areas that can be used exclusively by pedestrians and cyclists.
	B 125	kN 125	Pedestrian pathways, pedestrian areas and similar areas, private car parks or multi-storey car parks.
	C 250	kN 250	Kerbsides and areas of docks and similar not exposed to traffic; the kerb elements always fall at least within Class C250.
	D 400	kN 400	Carriageways (including pedestrian roads), verges and parking areas for all types of road vehicles.
	E 600	kN 600	Areas subject to large wheel loads, e.g. in harbours and dockyards.
	F 900	kN 900	Areas subject to very high wheel loads, e.g. aircraft paving.

- If in doubt, you should choose the greater load class.
- The designer is responsible for selecting the appropriate load class.



PRODUCT INSTALLATION, USE AND MAINTENANCE SHEETS

FOR WORKMANLIKE AND EASY INSTALLATION, USE AND MAINTENANCE.



With a simple click you can download the sheets you are interested in, from the Gridiron site

VISIT OUR SITE TO DOWNLOAD THE USE AND MAINTENANCE SHEETS.
www.gridiron.it

GLOSSARY

Water: a substance present in nature (hydrogen oxide: H₂O) in large quantities in the liquid state (sea, lakes, rivers), solid state (glaciers) and gaseous state (water vapour).

High tide: highest point reached by the level of the sea during tidal oscillation.

Leaching water (or wild water): the part of water that is not absorbed by the ground surface and that descends quickly along the sides of mountains during violent storms, carrying parts of the ground.

Fresh water: the water contained in glaciers, lakes and waterways, containing less dissolved salts compared to salty seawater.

Juvenile water: water that originates from deep sources related to hydrothermal events of cooling magmatic bodies.

Meteoric water: water coming from the atmosphere in liquid or solid phase; it forms precipitation.

Groundwater: water that found in the gaps or fissures of ground or rock, both in the saturated and unsaturated zones.

Aqueduct: system of pipes conveying water to users (see public waterworks).

Aquifer: ground or rock that is sufficiently permeable to allow water to accumulate or circulate.

Outcrop: fairly exposed portion of bedrock appearing above the surface without being covered by ground. Water table supply area: surface area through which infiltrations of surface water (meteoric or flowing) occur that feed the water table.

Sandstone: rock originating from the aggregation and cementing of sand.

Clay: loose ground consisting of microscopic and ultra-microscopic particles (smaller than 0.002 mm) originating from the chemical decomposition of rock constituents.

Artesian: relative to water tables or wells in which the water is pressurised.

Atomo: deriving from the Greek word atomos = 'indivisible', it was automatically considered the smallest existing particle without a structure; the modern atom instead has a structure consisting of a positively charged compact nucleus with minuscule negatively charged electrons moving around it, so that – under normal conditions – the total atomic charge is zero. Two or more atoms bound together form a molecule. If the atoms are the same, the molecule is a chemical element, if they are different the molecule is a compound.

Hydrogeological basin: portion of a territory in which the groundwater flows towards a single area of interest located along a waterway or valley bottom, whereas surface water can also flow towards other basins.

Drainage basin (or harvesting basin): portion of a territory within which the surface run-off water and the groundwater flow towards a single area of interest located along a waterway or valley bottom.

Bacteria: extremely small and simple micro-organisms.

Limestone: rock formed mainly by calcium carbonate (CaCO₃), which may be present in percentages exceeding 95%.

Well field: area containing multiple wells.

Water cycle: succession of phases through which water passes from the atmosphere to the ground and back to the atmosphere: condensation, precipitation, infiltration, run-off, evapotranspiration.

Organic compound: chemical compound containing carbon combined with hydrogen and often with oxygen, nitrogen and other elements (see inorganic compound).

Conglomerate: rock formed by cemented gravel.

Contamination: introduction of undesired substances into water that are normally not contained in it and which make the water unsuitable for use (see pollution).

Alluvial deposit: deposit originating from material transported and sedimented by water.

Dolomite: rock formed by dolomite (calcium magnesium carbonate [(Ca,Mg)CO₃]); the magnesium carbonate exceeds 40%.

Drainage: the removal of surface water or groundwater in a given area, as a result of gravity or pumping.

Pumping: extraction of groundwater using wells.

Eutrophication: process through which a body of water is enriched with dissolved nutrients required for the growth of aquatic plants.

Evaporation: process through which water passes from the liquid to the gaseous state (syn.: vaporisation).

Evapotranspiration: the combined effect of evaporation and transpiration.

Water table: water-bearing rock or ground (sufficiently permeable for accumulating water and letting it circulate) saturated with water.

Confined or pressurised water table: water table with pressurised water between the impermeable substrate at the bottom and another impermeable substrate on the top.

Free or phreatic water table: a water table delimited on the bottom by impermeable ground or rock (impermeable substrate) and on the top by water (phreatic surface).

Perched water table: phreatic water table with limited extension that forms near an unsaturated zone due to the presence of an impermeable section of ground.

Fertiliser: natural or artificial product used for nourishing crops.

Filters: slots present on a well casing that allow groundwater to enter the well.

River: natural waterway that drains water from a basin or part of the latter.

Photosynthesis: process occurring in plants whereby a chemical reaction between carbon dioxide and water leads to the formation of carbohydrates.

Capillary fringe: area in the subsoil located immediately above the phreatic surface where water seeps up due to capillary action.

Gravel: loose ground formed by rounded grains measuring more than 2 mm.

Infiltration: flow of surface water from the ground surface through the unsaturated zone to the water table.

Effective infiltration: part of the water that infiltrates the subsoil and effectively reaches the water table without being intercepted by plants or withheld in the unsaturated zone.

Hydrogeology: science that studies the water in the subsoil in relation to the geological structure (chemical-physical characteristics and origin of the water and laws governing its movement, both natural or towards captation works).

Hydrology: science that studies the water cycle: precipitation, surface flows, evaporation, transpiration, infiltration.

Inorganic: relative to chemical compounds that do not contain carbon as their main element, excluding carbonates, cyanides and its derivatives.

Pollution: chemical-physical alteration of groundwater (see contamination).

Thermal pollution: abnormal heating of the water contained in a surface body of water due to drainage or addition of hot water.

Insecticide: chemical product that destroys harmful insects.

Lake: large mass of water collected in ground troughs.

Silt: loose ground formed by small-sized grains (0.002–0.06 mm).

Piezometric level: the level to which the water rises in a well involving a pressurised water table (confined).

Marl: rock composed of equal proportions of limestone and clay.

Micro-organism: a microscopic organism, such as bacteria, viruses, protozoans, yeasts, algae.

Molecule: union of two or more atoms of the same element or of different elements (compound). The molecule is bound by electromagnetic or Van der Waals forces. Depending on the number of atoms forming the molecule, the latter can be very small (hydrogen molecule) or even microscopic (a bacterial chromosome is made up of a single enormous DNA molecule). Biological or biomolecule: molecule synthesized by organisms involved in their metabolic processes. Energy molecule: a biomolecule rich in chemical energy. It has chemical bonds that, if split, free energy that the cell can easily use in its metabolic processes: ATP is a biomolecule, while sugars are organic molecules that accumulate energy. Inorganic molecule: molecule without a 'skeleton' of carbon atoms. Organic molecule: molecule belonging to the chemistry of carbon that has a biological origin.

Organism: a body with life – synonymous with a living being – endowed with a specific form and chemical constitution that is able to preserve and reintegrate its own form and composition and to reproduce them by giving life to similar organisms.

Multicellular organisms: organisms consisting of two or more cells, generally with specific functions.

Parts per million (ppm): an expression widely used in English-speaking countries to express, in particular, the concentration of a solute in a solution, or of a gas in a gaseous mixture. In the case of aqueous solutions, 1 ppm corresponds to 1 mg/l.

Permeability: indicates the ground's ability to be penetrated by a fluid.

Potability: chemical-physical and bacteriological characteristics of water that make it suitable for drinking.

Well: hole in the ground lined with a casing equipped with filters.

Precipitation: all meteoric water in both liquid and solid form.

Public waterworks: all the works necessary for carrying and distributing water to the various users in a given area (see aqueduct).

Radionuclide: nuclide that emits radiation.

Run-off: meteoric water that flows on the ground surface without being channelled in waterways.

Sand: loose ground formed by small-sized grains (0.06–2 mm).

Sedimentation: process whereby solid material transported by water, wind or glaciers is deposited.

Sediment: loose material transported by water or wind or glaciers from its point of origin to the point of deposit or sedimentation.

Reservoir: a place positioned upstream of a water network for collecting and storing water.

Serpentinite: 'ultramafic' rock originating from the hydration of rock formed by low-silica (SiO₂) magma originating from the mantle. They are dark green or black.

Spring: area where groundwater emerges naturally to the surface.

Stratigraphy of a well: description of the ground crossed during the perforation of a well.

Sublimation: passage from the solid to the gas phase, and subsequent condensation, without passing through the liquid phase.

Impermeable substrate: impermeable ground or rock that sustains the water table.

Phreatic surface: surface that indicates the upper limit of the saturated zone (refers to a free or phreatic water table).

Piezometric surface: surface that defines the distribution of the water load in a space. In the case of a free water table, it corresponds to the phreatic surface; in the case of a confined water table, the piezometric surface is located above the roof of the aquifer and is formed by the level (the so-called 'piezometric level') to which the water rises in a well involving the same water table.

Transpiration: process through which water is introduced into the atmosphere in a gaseous state by plants.

Unsaturated zone: portion of the subsoil immediately below the surface where the rock fissures or empty spaces between the grains are not completely filled with water.

Saturated zone: portion of the subsoil where the rock fissures or empty spaces between the grains that form the ground are completely filled with water.

The illustrations and technical data of the products illustrated in the catalogue must be regarded as purely indicative. Gridiron S.p.A. reserves the right to make all the changes deemed necessary to improve its products and the production and distribution phases, without prior notice. All the images, drawings and photographs are the property of Gridiron S.p.A. Any reproduction, even partial, of the contents without written authorisation from Gridiron S.p.A. is forbidden and punishable according to the laws in force.

